



# AVTECH ELECTROSYSTEMS LTD.

NANOSECOND WAVEFORM ELECTRONICS  
SINCE 1975

□ P.O. BOX 265  
OGDENSBURG, NY  
U.S.A. 13669-0265  
TEL: (315) 472-5270  
FAX: (613) 226-2802

TEL: 1-800-265-6681  
FAX: 1-800-561-1970  
U.S.A. & CANADA

e-mail: [info@avtechpulse.com](mailto:info@avtechpulse.com)

□ BOX 5120 STN. F  
OTTAWA, ONTARIO  
CANADA K2C 3H4  
TEL: (613) 226-5772  
FAX: (613) 226-2802

## INSTRUCTIONS

MODEL AV-155B-PS-P-UCIA PULSE GENERATOR

S.N. :

### WARRANTY

Avtech Electrosystems Ltd. warrants products of its manufacture to be free from defects in material and workmanship under conditions of normal use. If, within one year after delivery to the original owner, and after prepaid return by the original owner, this Avtech product is found to be defective, Avtech shall at its option repair or replace said defective item. This warranty does not apply to units which have been disassembled, modified or subjected to conditions exceeding the applicable specifications or ratings. This warranty is the extent of the obligation or liability assumed by Avtech with respect to this product and no other warranty or guarantee is either expressed or implied.

### CAUTION

To avoid possible damage to the laser diode, the following start up and shut down sequences should be followed:

#### START UP SEQUENCE

- 1) POWER switch is OFF (i.e. button out).
- 2) Set amplitude controls fully CCW.
- 3) Set OPERATE-STANDBY switch to STANDBY position.
- 4) Connect the laser diode to the output terminals.
- 5) Apply prime power by setting the POWER switch in the ON position (i.e. push button in).
- 6) Set OPERATE-STANDBY switch to OPERATE position.
- 7) Set amplitude to desired level. Do not change the position of the OPERATE-STANDBY switch from OPERATE to STANDBY without first setting the amplitude controls to fully CCW.

#### SHUT DOWN SEQUENCE

- 1) Set amplitude controls fully CCW.
- 2) Set OPERATE-STANDBY switch to the STANDBY position.
- 3) Turn off the prime power by pushing the POWER switch button.
- 4) Remove the laser diode from the output terminals.

Fig. 1

MODEL AV-155B-PS-UCIA PULSE GENERATOR TEST ARRANGEMENT

(RESISTIVE LOAD, NO DIODE)

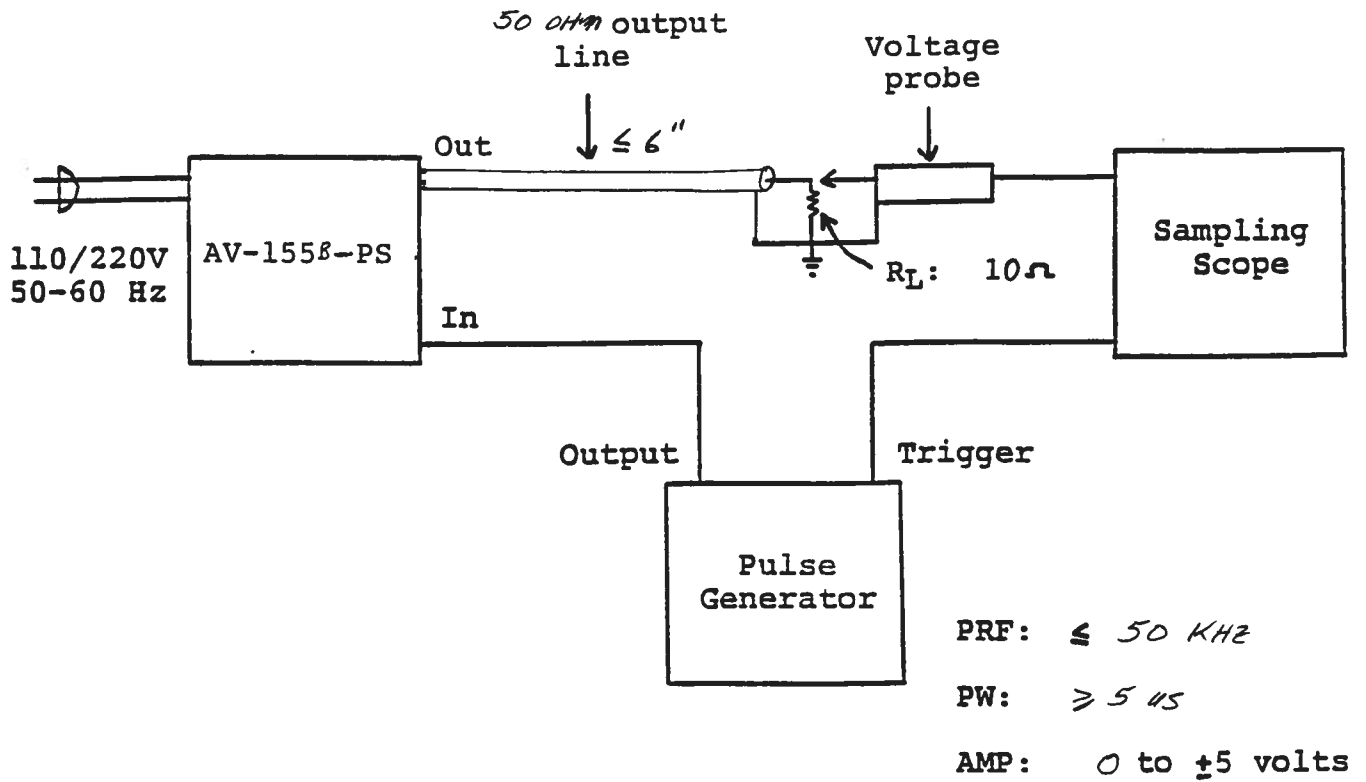

**Notes:**

- 1) The bandwidth capability of components and instruments used to display the pulse generator output signal (probes, cables, connectors, etc.) should exceed 50 MHz.
- 2) It is recommended that the unit be first tested using a non inductive ten Ohm resistive load and the load voltage be monitored using a scope voltage probe.
- 3) The unit operates as a voltage to current converter as follows (Volts and Amps):

$$I_{OUT} = GV_{IN}$$

Where G is controlled by the front panel gain control (0 to 0.1). The input amplitude should not exceed  $\pm 5$  Volts. For 5 Volts in and the gain control set max clockwise, the unit will provide a max output of 0.5 Amp (to a max load voltage of 5 Volts).

- 4) The input trigger rate should not exceed 50 kHz as this may result in damage to the unit.
- 5) The load (either resistive or diode) may be connected to the Out BNC using 50 Ohm coaxial cable but the length should be kept as short as possible (preferably less than 6").

- 6) Monitor Function. The rear panel BNC connector provides a coincident replica of the output pulse. For  $R_L \geq 1K$ .

$$I_{LOAD} = 2 V_M \text{ (Volts, Amp)}$$

$$\text{For } R_L = 50 \text{ Ohm}$$

$$I_{LOAD} = 4 V_M \text{ (Volts, Amp)}$$

$V_M$  is the monitor output Volt. Amplitude is determined using a scope.

- 7) A DC offset on the output may be eliminated (or induced) by making minor adjustments to the one turn OS locking pot in the interior of the instrument. This pot may be accessed by removing the four Phillips screws on the rear panel and then sliding the top lid back and off. At the time of shipping the DC offset was set to zero.
- 8) The AV-155B unit can be converted from 110 to 220V 50-60 Hz operation by adjusting the voltage selector card in the rear panel fused voltage selector-cable connector assembly.
- 9) For additional assistance:
- Tel: (613) 226-5772  
Fax: (613) 226-2802

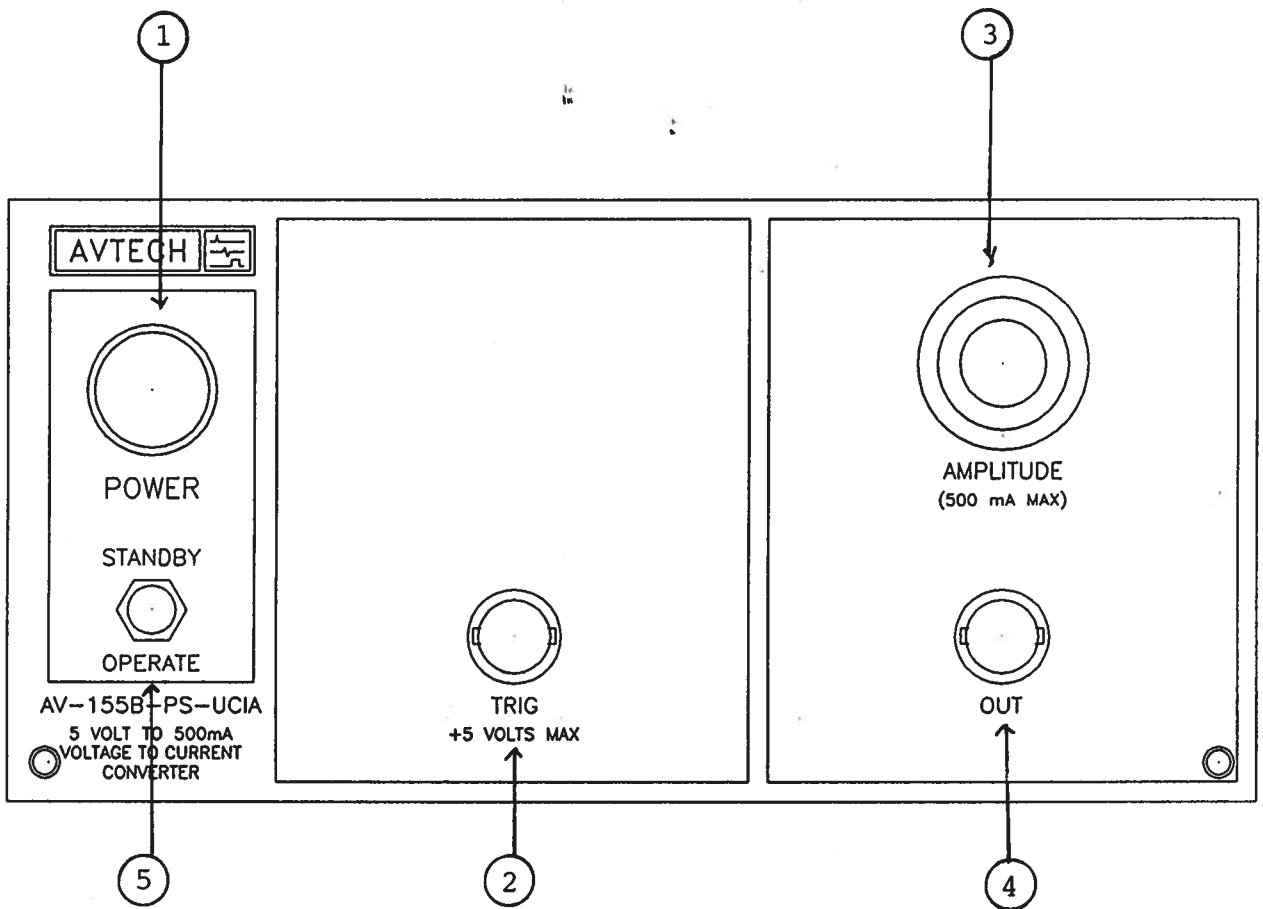

Fig. 2: Front Panel Controls

### FRONT PANEL CONTROLS

- (1) POWER SWITCH. Applies power to all stages.
- (2) TRIG. 0 to  $\pm 5$  is applied at this input ( $PW \geq 5 \text{ us}$ ).
- (3) PULSE AMPLITUDE. Ten turn amplitude control varies gain (G) from 0 to 0.1 (i.e. 500 mA out for 5 Volts in).
- (4) OUT. BNC connector to which load is connected. 50 Ohm coax cable may be used but keep length short ( $\leq 0.5'$ ).
- (5) STANDBY-OPERATE. When this switch is in the STANDBY position, a set of relay controls shorts out the laser diode whether the prime power is ON or OFF. When the switch is in the OPERATE position, the relay contacts open, provided the prime power is on. See the START UP and SHUT DOWN SEQUENCE notes preceding Fig. 1 for a full discussion of the operation of this switch.



Fig. 3

BACK PANEL CONTROLS

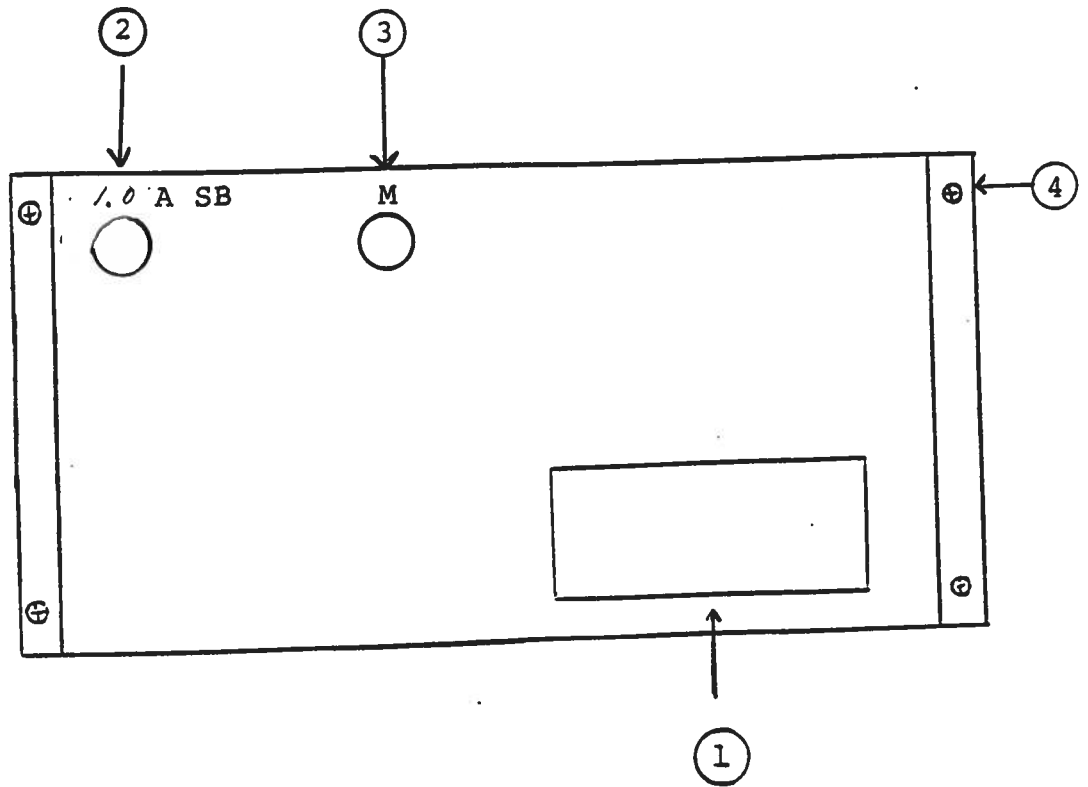

### BACK PANEL CONTROLS

- (1) Power Entry Module. Detachable line cord connects to this point. Also contains voltage selector card and line fuse (0.50 A SB).
- (2) 1.0 A SB Fuse. Limits current supplied to the output stage.
- (3) Monitor Option. BNC connector provides a coincident replica of the output pulse. For  $R_L \geq 1K$ .

$$I_{LOAD} = 2 V_M \text{ (Volts, Amp)}$$

$$\text{For } R_L = 50 \text{ Ohm}$$

$$I_{LOAD} = 4 V_M \text{ (Volts, Amp)}$$

- (4) Cover Screws. To remove the top cover, remove the 4 Phillips screws and the top cover may then be slid back and off.

Fig. 4

POWER SUPPLY

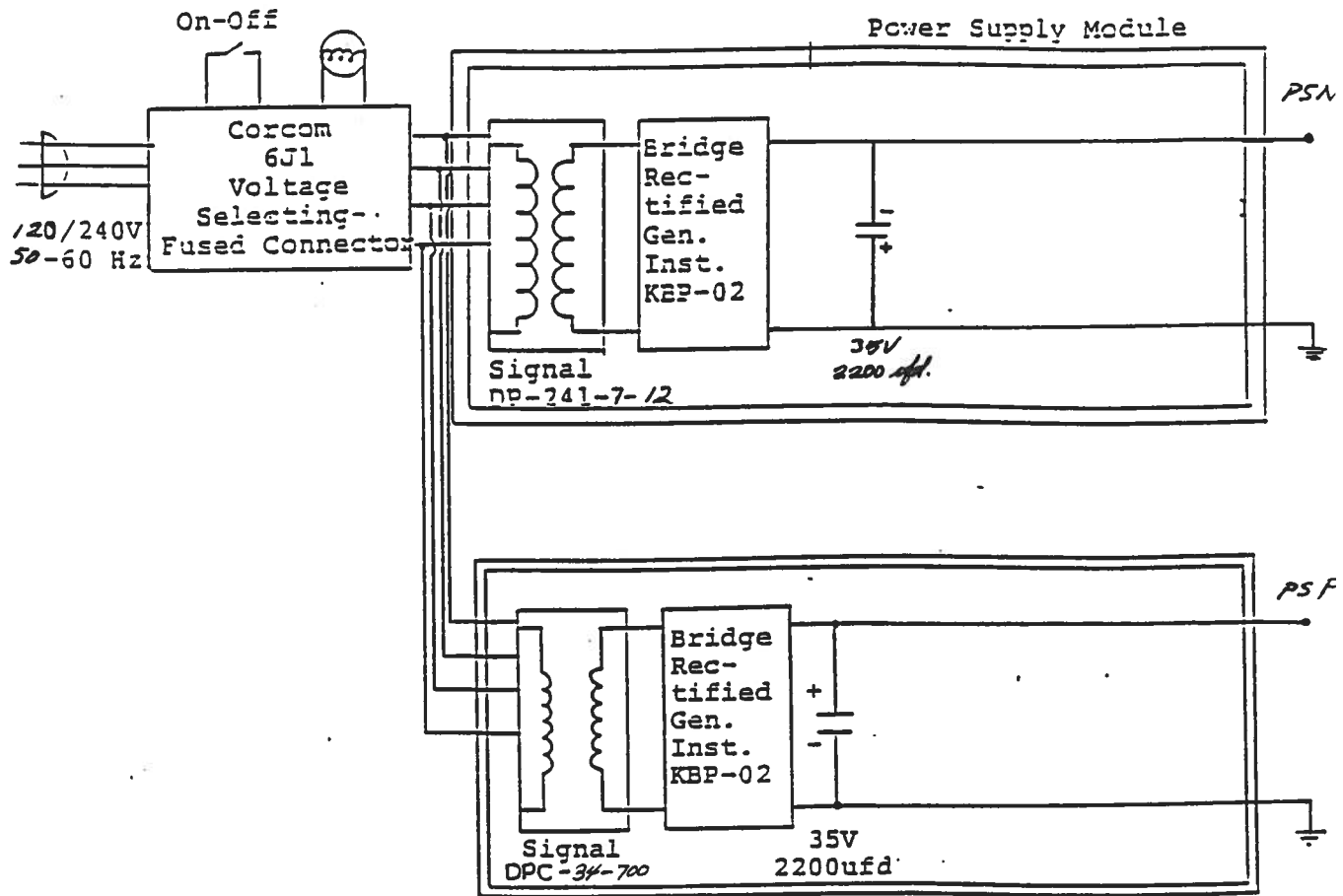

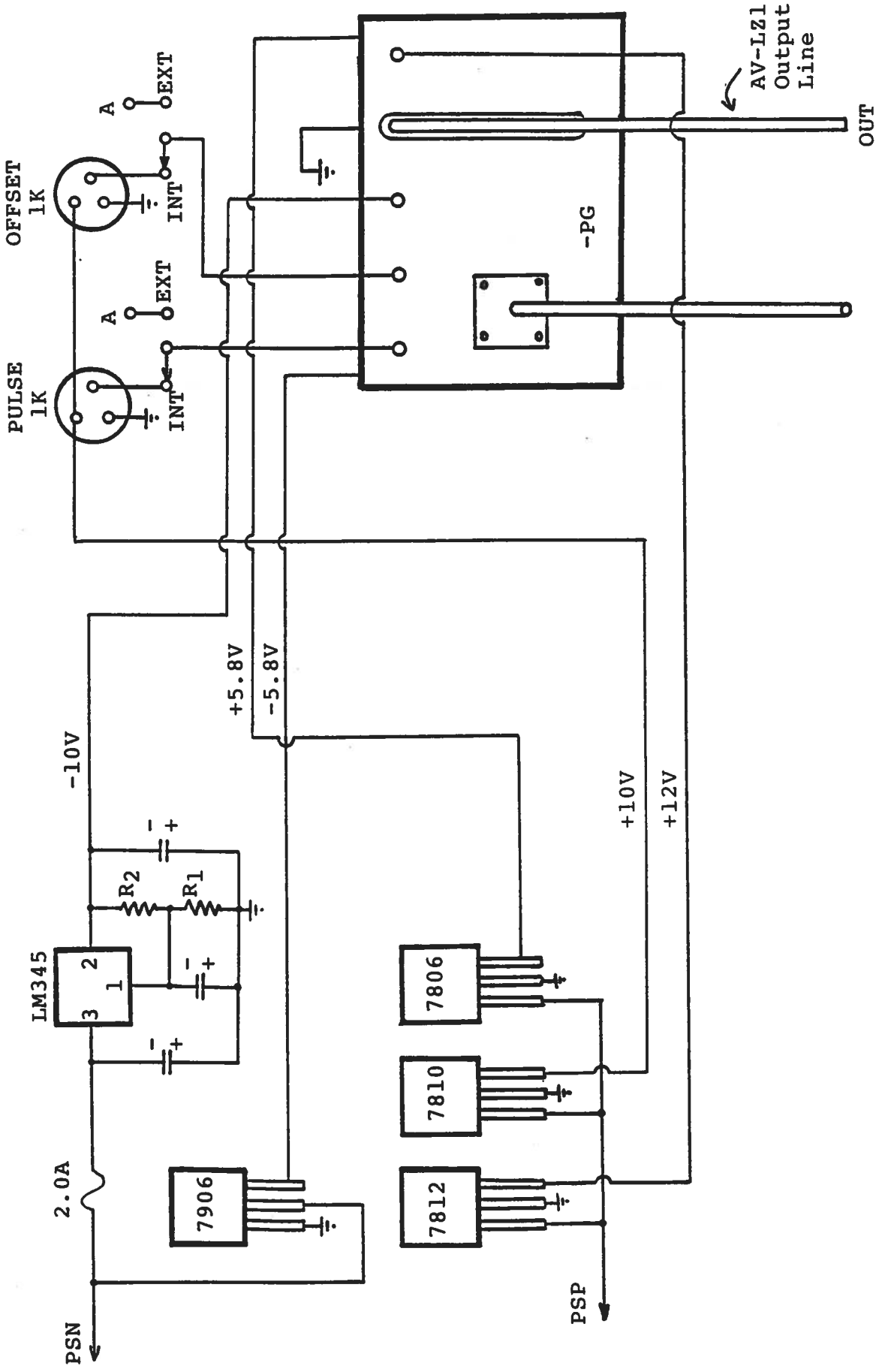

Fig. 5: AV-155-PS-DUP3 BLOCK DIAGRAM



AVTECH ELECTROSYSTEMS LTD.

NANOSECOND WAVEFORM ELECTRONICS  
SINCE 1975

□ P.O. BOX 265  
OGDENSBURG, NY  
U.S.A. 13669-0265  
TEL: (315) 472-5270  
FAX: (613) 226-2802

TEL: 1-800-265-6681  
FAX: 1-800-561-1970  
U.S.A. & CANADA

e-mail: info@avtechpulse.com

✕ BOX 5120 STN. F  
OTTAWA, ONTARIO  
CANADA K2C 3H4  
TEL: (613) 226-5772  
FAX: (613) 226-2802

March 21, 1996.

Jay Yoo  
University of California at Irvine  
Dept. of ECE  
Irvine, CA 92717

Tel: 714-824-5185  
Fax: 714-824-3732

Dear Jay:

Following our telephone conversation of March 20th, I am pleased to enclose the following literature:

- 1) General Catalog No. 9
- 2) Price list

Model AV-155B-PS (see pages 60 and 61) can be modified to operate as a voltage to current converter meeting the following specifications:

Model designation:	AV-155B-PS-UCIA.
Input voltage:	0 to +5 Volts.
Output current: (for gain control set at maximum)	0 to +500 mA (5 Volts max).
Rise, fall time:	$\leq 1$ us.
Max duty cycle:	100%.
Gain control:	Ten turn locking dial control varies output current from 0 to +500 mA (for $V_{IN} = +5$ Volts).
Input connector:	BNC.

.../2

Output connector: BNC (i.e. does not employ the standard AV-LZ flexible output line).

Other: See standard AV-155B-PS.

Price: \$2,298.00 US each, FOB destination.

Please note that this price includes our standard 5% academic discount.

Delivery: 60 days ARO.

Thank you for your interest in our products. Please call me again (1-800-265-6681) if you require any additional information.

Yours truly,

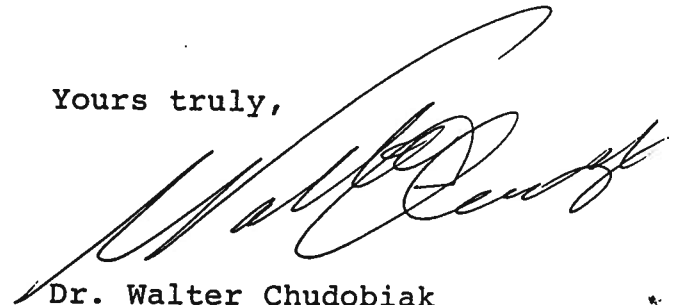

Dr. Walter Chudobiak  
Chief Engineer

WC:pr  
Encl.

dic AV-150  
dur ISSBUZIA

Aug 30/96