



AVTECH ELECTROSYSTEMS LTD.
NANOSECOND WAVEFORM ELECTRONICS

□ P.O. BOX 265
OGDENSBURG, NY
U.S.A. 13669-0265
TEL: (315) 472-5270
FAX: (613) 226-2802

✠ BOX 5120 STN. F
OTTAWA, ONTARIO
CANADA K2C 3H4
TEL: (613) 226-5772
FAX: (613) 226-2802

INSTRUCTIONS

MODEL AV-LDD1-C LASER DIODE DRIVER

S.N.:

WARRANTY

Avtech Electrosystems Ltd. warrants products of its manufacture to be free from defects in material and workmanship under conditions of normal use. If, within one year after delivery to the original owner, and after prepaid return by the original owner, this Avtech product is found to be defective, Avtech shall at its option repair or replace said defective item. This warranty does not apply to units which have been disassembled, modified or subjected to conditions exceeding the applicable specifications or ratings. This warranty is the extent of the obligation or liability assumed by Avtech with respect to this product and no other warranty or guarantee is either expressed or implied.

TABLE OF CONTENTS

1.0 GENERAL DESCRIPTION.....	4
2.0 SPECIFICATIONS.....	5
3.0 SAFETY.....	6
3.1 Operating Safety Summary.....	6
3.2 Servicing Safety Summary.....	7
4.0 OPERATING CONSIDERATIONS.....	8
4.1 Output.....	8
4.2 Pulse Risetime and Faltime.....	8
4.3 Impedance Matching.....	9
4.4 Load Interconnection.....	9
4.5 Trigger Input.....	9
5.0 PREPARATION FOR USE.....	10
5.1 General.....	10
5.2 Initial Inspection.....	10
5.3 Input Power Cord.....	10
6.0 OPERATING INSTRUCTIONS.....	11
6.1 Controls and Indicators.....	11
6.2 Operation.....	12
6.3 Power-Down Procedures.....	12
7.0 TROUBLESHOOTING.....	12
7.1 Troubleshooting Procedures.....	13
7.2 Factory Service.....	14
8.0 SYSTEM FAILURE MODES.....	14
8.1 Over-Current Failure.....	14
8.2 Over-Voltage Failure.....	14
9.0 APPENDIX.....	16
Figure 1 - Block Diagram	
Figure 2 - $V_{FORWARD}$ As A Function of Time	
Figure 3 - Micro-Stripline Termination	
Figure 4 - Micro-Stripline Topology	
50400001 - Switch Module Schematic	
50400027 - Power Supply/Pulse Generator Schematic	

***** WARNING *****

SAFE OPERATING PROCEDURES AND PROPER USE OF THE EQUIPMENT ARE THE RESPONSIBILITY OF THE USER OF THIS SYSTEM.

AVTECH ELECTROSYSTEMS LTD. provides information on its products and associated hazards, but it assumes no responsibility for the after-sale operation and safety practices.

ALL PERSONNEL WHO WORK WITH OR ARE EXPOSED TO THIS EQUIPMENT MUST TAKE PRECAUTIONS TO PROTECT THEMSELVES AGAINST POSSIBLE SERIOUS AND/OR FATAL BODILY INJURY. DO NOT PERFORM INTERNAL REPAIR OR ADJUSTMENTS UNLESS ANOTHER PERSON CAPABLE OF RENDERING FIRST AID AND RESUSCITATION IS PRESENT.

1.0 GENERAL DESCRIPTION

The LDD1 Laser Diode Driver is a high voltage solid state pulse generator designed to drive low inductance, resistive loads such as LEDs and laser diodes.

The driver utilizes patented state-of-the-art high-speed power MOSFETs as the high voltage switches, incorporated into a low impedance configuration featuring a multi-layer stripline-style output bus.

Referring to Figure 1 of the appendix, the power switch module (#5040-0001) provides the pulsed power to the micro-strip transmission line, and in turn to the laser diode. The current viewing resistor, labeled "CVR", allows the user to monitor the pulse current supplied to the laser diode.

The power switch module receives support power from the 120VAC line, and high voltage power from the switch mode power supply (#5040-0027). This module also contains a low voltage power supply, providing support power to the switch mode supply, and an internal oscillator.

The internal oscillator provides a drive pulse to the power switch module to gate on and off the output current pulse. The oscillator may be operated in either an internal or an external mode. In external mode, the trigger line provides the pulse recurrence frequency (PRF), while the Laser Diode Driver provides the pulse width through the "Pulse Width" potentiometer. A sync line is provided from the oscillator, allowing the user to synchronize an oscilloscope to view the current pulse generated by the Laser Diode Driver.

2.0 SPECIFICATIONS

Amplitude ¹ :	0 to 250 Volts to 2.5 Ohms (100 Amps max)
Pulse width ² :	75 ns to 1 us ($I \leq 100$ Amp) 75 ns to 3 us ($I \leq 20$ Amp)
Rise time:	≤ 20 ns (Typically ≤ 12 ns)
Fall time:	≤ 20 ns (Typically ≤ 12 ns)
PRF:	Int trigger: 50 Hz to 5 KHz Ext trigger: 0 to 5 KHz
Duty cycle (max):	PW ≤ 500 ns : 0.05 % PW = 1.0 μ s : 0.03 %
Average power out (max):	15 Watts
Polarity ³ :	Positive or negative (specify)
Source impedance:	2.5 Ohms
Droop:	PW = 200 ns: ≤ 3 % (@ 100 Amps) PW = 1.0 us: ≤ 16 % (@ 100 Amps)
Propagation delay: (EXT TRIG IN TO PULSE OUT)	≤ 130 ns
Jitter: (EXT TRIG IN TO PULSE OUT)	± 100 ps
Monitor output:	Provides a coincident replica of the diode current ($I_D = 10 V_M$ (Amps, Volts))
Trigger required: (EXT TRIG mode)	+5 Volts (50 Ohms) 75 ns or wider
Sync delay: (sync out to pulse out)	Coincident (not variable)
Sync output:	+5 Volts, will drive 50 Ohms
Connectors:	OUT Microstrip solder terminals TRIG BNC SYNC BNC MONITOR BNC
Power requirement:	120/240 Volts 50 - 60 Hz (specify)
Dimensions: (H x W x D)	92 mm x 92 mm x 230 mm (3.6' x 3.6' x 9.0')
Chassis material:	black anodized aluminum
Mounting:	Any
Temperature range:	+15° to +40° C
Warranty:	Full

- 1) Amplitude controlled by ten turn control.
2) Pulse width controlled by ten turn control.

- 3) Indicate desired polarity by suffixing model No. by -P or -N (i.e. positive or negative).

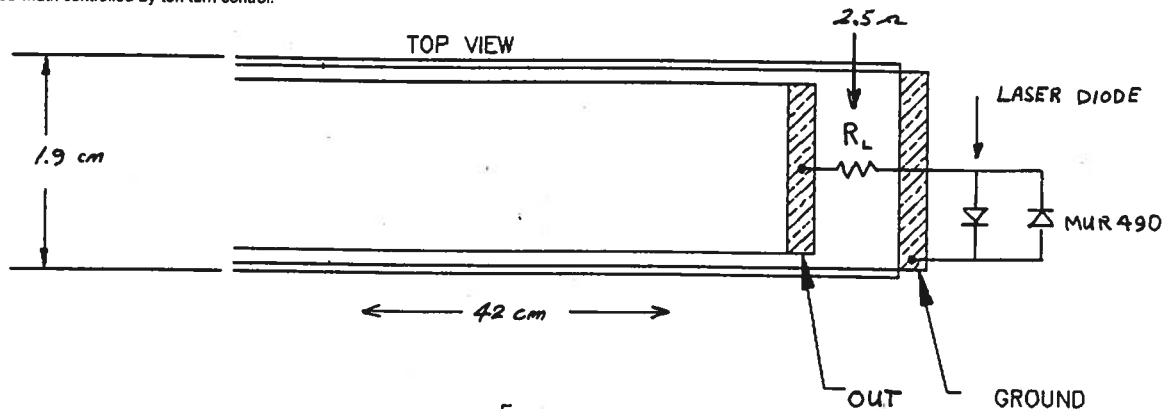

3.0 SAFETY

The high voltage nature of this device dictates the use of caution when operating or servicing this equipment. The following is a summary of general safety precautions that must be observed during all phases of operation and repair of the Laser Diode Driver.

3.1 Operating Safety Summary

The safety information contained in this summary is for both operating and servicing personnel. Specific warnings may be found throughout this manual, but may not appear in this summary.

3.1.1 Power Source

The driver is designed to operate from a power source that will not apply more than 120 volts between the supply conductors or between either supply conductor and ground. A protective grounding connection by way of the grounding conductor in the AC power cord is essential.

3.1.2 Grounding

The driver is grounded through the grounding conductor of the AC power cord. To avoid electrical shock, plug the driver into a properly wired receptacle before making connection to any input or output connectors. Use only a power cord that is in good condition.

3.1.3 Cover Removal

To avoid personal injury, do not remove the side covers. Do not operate the driver while the covers are removed. The covers do not contain safety interlocks!

3.1.4 General Operating Precautions

Do not remove the input or output cables while the driver is in operation. Never short-circuit the high voltage output of the driver. Failure to observe these precautions can result in potential electric shock to personnel, arcing, and damage to the connectors and system.

Any pulsed power system is capable of random triggering via transients. Therefore when the driver is turned on, or high voltage is present in the chassis, assume it is possible to get a pulse on the output connector.

3.2 Servicing Safety Summary

The driver contains dangerous voltages and stored energy.

We strongly recommend that all repairs and adjustments be performed by factory qualified personnel. AVTECH will not be responsible for personal injury or damage to the driver that occurs during repair by any party other than the factory.

3.2.1 Servicing Procedure

Do not perform internal repair or adjustments unless another person capable of rendering first aid and resuscitation is present.

3.2.2 Internal Energy Storage

The driver contains capacitors that are used as energy storage elements. When charged, these capacitors contain in excess of 0.5 joules of stored energy. This is sufficient energy to cause injury. Assure that the AC power cord is disconnected from the driver, and that the capacitor bank is fully discharged and a shorting strap installed before any repairs or adjustments are attempted. Verify with a voltmeter that all circuits are de-energized before servicing. The voltmeter used to make these measurements must be certified for use at 1000VDC and 110VAC or greater. Dangerous voltages, floating ground planes and energy storage exist at several locations in the driver. Touching connections and/or components could result in serious injury.

4.0 OPERATING CONSIDERATIONS

4.1 Output

The driver is designed to operate into a predominantly resistive load with a small inductive term (typically less than 60 nanohenrys). An unterminated or improperly terminated output will cause excessive aberrations on the output waveform and could possibly damage the driver. To ensure this does not occur, observe the following precautions:

- Use good quality cable and connectors;
- Make all external connections tight and as short as possible;
- Use terminators or impedance-matching devices to avoid reflections;
- Ensure that all external cables and hardware have adequate voltage and power ratings;
- Be extremely careful not to short the output of the driver to ground, as this can cause damage to the driver.

4.2 Pulse Risetime and Falltime

The physical and electrical characteristics of the cable transmitting the pulse determine the characteristic impedance, velocity of propagation and the amount of signal loss. Several feet of cable can attenuate high frequency information in a pulse with a fast rise time. It is therefore important to keep these cables as short as is practical. For optimum performance, we recommend using the micro-strip transmission line provided with the driver. When signal comparison measurements or time difference determinations are made, the two signals from the test device should travel through coaxial cables with identical loss and time delay characteristics.

Furthermore, if it is assumed that the laser diode has a total series inductance of 30 nanohenrys, and a 100A current pulse with a 15 nanosecond rise time is required, then:

$$\text{Given: } V = L(di/dt) \quad \text{and}$$

$$\text{Given: } V_F(\text{DIODE}) = 10V \text{ at } 100A$$

$$\text{Then: } V_{\text{COMPLIANCE}} = V_{FD} + L(di/dt)$$

$$10V + (30E^{-9} * 100/15E^{-9}) = 220V$$

In this example, this 220V compliance, or peak voltage, is only required for the first 15 nanoseconds. After this interval the voltage collapses to the 10V V_{FORWARD} for the duration of the pulse, as shown in Figure 2 of the appendix.

4.3 Impedance Matching

If a pulse travels down a transmission line and encounters a mismatch, a reflection is generated and sent back along the line to the source. The amplitude and polarity of the reflection are determined by the impedance mismatch. If the reflected signal returns before the output pulse ends, it adds or subtracts from the amplitude of the pulse. This will distort the pulse shape and amplitude.

4.4 Load Interconnection (see 6.2 also)

Figure 3 of the appendix is a schematic diagram of the preferred termination of the micro-stripline. R_L is chosen to present the proper impedance match to the driver, given the laser diode's forward voltage drop and current requirement. This resistor should be comprised of several carbon composition resistors in parallel to achieve a low inductance composite resistor. D_1 is a fast-recovery diode, wired in the reverse direction across the laser diode. This clamps negative-going transients which are created by the inductive term L_1 present in all laser diodes. It is important to keep the value of L_1 as small as possible by using extremely short leads.

Figure 4 shows the end of the micro-stripline. Its impedance is approximately 2.5 ohms. The laser diode should be connected to the micro-stripline using the circuit shown in Figure 3. All leads should be kept as short as possible. A few nanohenrys of inductance can create a substantial $L di/dt$ term.

4.5 Trigger Input

When in external mode, an input trigger of +5V +/-1V into 50 ohms with a risetime of <20ns is required to gate on the driver. Departure from these values can result in a loss of performance. These trigger requirements are met by any high quality low voltage pulse generator. The trigger should be set to +5V +/-1V into 50 ohms before the trigger cable is attached to the driver trigger input. If the trigger input is greater than +5V into 50 ohms, pulse stretching can occur.

5.0 PREPARATION FOR USE

5.1 General

After unpacking, initial inspection and preliminary electrical check procedures should be performed to assure that the unit is in good working order. If it is determined that the unit is damaged, the carrier should be notified immediately. Repair problems should be directed to AVTECH ELECTROSYSTEMS LTD.

5.2 Initial Inspection

1. Inspect unit for exterior mechanical damage.
2. Inspect power input cord and input power module for obvious signs of damage.

5.3 Input Power Cord

The input power cord terminates externally in a three-prong polarized plug. The unit chassis is wired to the plug through the line cord, and therefore, the insertion of the plug into a compatible receptacle, hooked up to a grounded input, will automatically ground the unit. **The unit should not be operated without a grounded AC input!**

6.0 OPERATING INSTRUCTIONS

6.1 Controls And Indicators

6.1.1 Power Switch and Indicator Lamp

The switch labeled "ON/OFF" controls all AC power in the chassis. The lamp above the switch illuminates when AC power is turned on.

6.1.2 Fault Indicator

The Fault lamp flashes when a fault condition is encountered. Fault conditions include an internal or external short, or an output power requirement in excess of the capabilities of the high voltage power supply. If the fault light illuminates, the unit should not be operated until the cause of the fault is rectified. In the event of excess power requirements, the power should be reduced by decreasing the PRF, decreasing the output pulse width, lowering the power, or some combination thereof, until the lamp extinguishes. If these actions fail to extinguish the lamp, a problem exists with either the laser diode or with the driver itself.

6.1.3 Power Adjustment

This potentiometer controls the output voltage pulse (or level of current pulse, depending on load resistance).

6.1.4 Pulse Width Adjustment

Pulse width is adjusted with the potentiometer labeled "Pulse Width". This adjustment functions when the driver is either internally or externally triggered.

6.1.5 Frequency Adjustment

When internally triggered, the pulse recurrence frequency is controlled by the "Frequency" potentiometer. When externally triggered, this control is disabled.

6.1.6 CVR Connector

The BNC connector labeled "CVR" provides a high-speed monitor of the output current pulse. Its output is 10A/1V, and should be terminated into 50 ohms.

6.1.6 SYNC Connector

The BNC connector labeled "SYNC" replicates the width and frequency of the output pulse, and is used to synchronize an oscilloscope to the output pulse. Output is +1V into 50 ohms.

6.1.7 Trigger Connector and Switch

The BNC connector labeled "TRIGGER" is the input to externally trigger the laser diode driver. The trigger line provides the pulse recurrence frequency (PRF), while the pulse width is controlled through the "Pulse Width"

potentiometer. An input trigger of +5V +/-1V into 50 ohms with a risetime of <20ns is required to gate on the driver. When externally triggered, the "Trigger" switch should be set to EXT.

6.2 Operation

Before turning on the unit, ensure that all output adjustments are set to ZERO, and the output micro-stripline is connected to an appropriate load. Connect the laser diode and scope as shown in Fig. A. The output current pulse should be monitored at the CVR output using a high speed oscilloscope ($Z_{IN} = 50\Omega$). See Fig. B for max PW-PRF combinations to insure that the duty cycle rating is not exceeded.

Turn ON the AC power, and slowly increase the Power, Pulse Width and Frequency adjustments while monitoring the oscilloscope until the appropriate output is generated. If the Fault lamp illuminates, reduce power, frequency or pulse width until the lamp extinguishes. If the lamp does not extinguish, if there is no output from the driver, or the output is severely distorted, set the Power Adjust to zero. Leave the driver connected to the AC input without high voltage and with all connectors in place for approximately 15 minutes to bleed off the stored energy, then disconnect the AC power to the unit and refer to the Troubleshooting Section of this manual.

CAUTION

- 1) The output pulse amplitude must never exceed 100 Amps (i.e. a CVR output of 10 Volts). The unit may fail if the 100 Ampere limit is exceeded.
- 2) The pulse voltage at the output of the microstrip line may be as high as 250 Volts. This voltage may be monitored using a high impedance high speed scope probe.

6.3 Power-Down Procedures

1. Set the Power Adjust dial to zero.
2. Leave the driver connected to the AC input without high voltage and with all connectors in place for approximately one minute to bleed off the stored energy.
3. Turn OFF the unit.
4. Disconnect the AC power to the unit.

7.0 TROUBLESHOOTING

WARNING

The driver contains capacitors that are used as energy storage elements. When charged, these capacitors contain in excess of 0.5 joules of stored energy. This is sufficient energy to cause serious injury. Assure that the AC power cord is disconnected from the driver, and that the capacitor bank is fully discharged and a shorting strap installed before any repairs or adjustments are attempted. Verify with a voltmeter that all circuits are de-energized before servicing. The voltmeter used to make these measurements must be certified for use at 1000VDC and 110VAC or greater. Dangerous voltages, floating ground planes and energy storage exist at several locations in

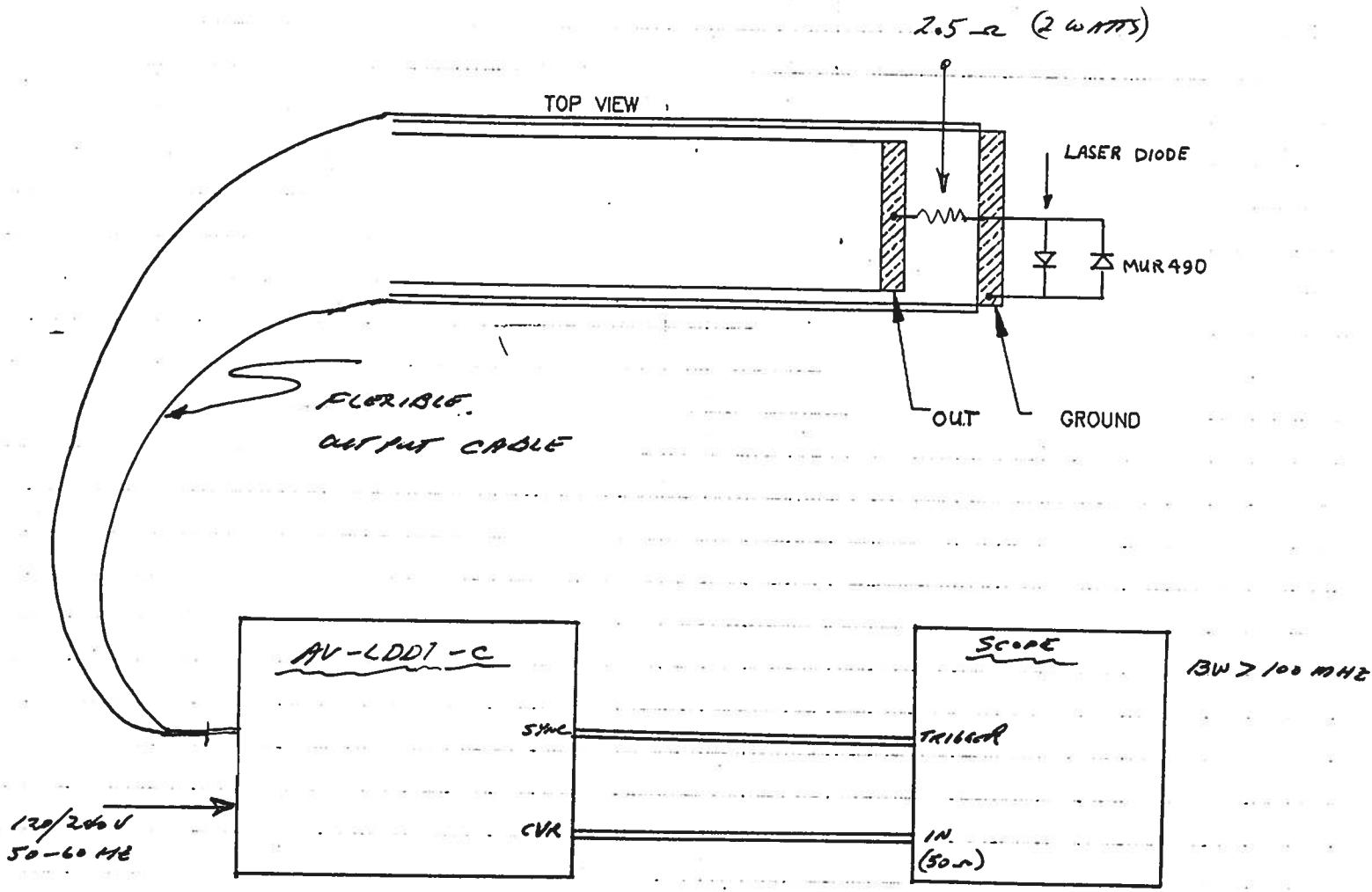

FIG A BASIC TEST SET-UP.

<u>PRF</u>	<u>PW</u>
5 kHz	0.06 us
500 Hz	0.6 us
200 Hz	1.5 us
100 Hz	3.0 us

Fig. B MAX DUTY CYCLE (0.03%)

the driver. Touching connections or components could result in serious injury.

7.1 Troubleshooting Procedures

Before attempting to service or troubleshoot the driver, review the servicing safety summary in Section 3.0.

The power MOSFETs utilized in the driver are mounted underneath the printed circuit board, and utilize the mounting plate as a heat sink. In the unlikely event that a MOSFET need be replaced, it is highly recommended that the unit be returned to the factory for servicing.

The table below summarizes potential problems and their solutions. If these recommendations do not resolve the problem, DEI customer service can be contacted for further assistance.

<u>SYMPTOM</u>	<u>SOLUTIONS</u>
1. No AC ON Lamp.	-AC power not plugged in. -Fuse(s) are blown. See fuse replacement instructions in Section 7.1.1.
2. No output pulse.	-No input trigger. -Input trigger voltage too low. -Input trigger pulse width too short. Increase width. -Input trigger frequency too high. Reduce frequency. -Trigger switch incorrectly set. -High voltage supply set too low. Increase high voltage setting. -Output not connected correctly. Check all cables and connections. -Driver is damaged. Contact DEI customer service.

7.1.1 Fuses

To avoid fire hazard or damage to the driver, use only 1A fast blow fuses (Littelfuse #312001 or equivalent). Fuse replacement should be performed by qualified personnel only. Assure that the AC power cord is disconnected from the driver, and that the capacitor bank is fully discharged and a shorting strap installed before fuse replacement is attempted. Verify with a voltmeter that all circuits are de-energized before servicing. The voltmeter used to make these measurements must be certified for use at 1000VDC and 110VAC or greater.

The fuses are located in the corner of the printed circuit

boards.

7.2 Factory Service

If the procedures above fail to resolve an operational problem, please contact the factory for further assistance:

AVTECH ELECTROSYSTEMS LTD.

TEL: (613) 226-5772

FAX: (613) 226-2802

8.0 SYSTEM FAILURE MODES

The Laser Diode Driver is capable of generating large amplitude current pulses with very fast rise and fall times. There is no over-current or over-voltage protection circuitry, and it is the user's responsibility to assure that the interconnect cables and load do not create transients, over-current or over-voltage conditions that could damage the pulse generator.

8.1 Over-Current Failure

When the output is shorted, the driver can deliver over 200A of current (depending on cabling, HV power supply setting, etc.). A current pulse of this magnitude is far in excess of the driver's maximum specification, and may cause damage to the driver, load and/or associated cabling.

8.2 Over-Voltage Failure

One may incorrectly assume that the voltage across the MOSFET switching device could never exceed the 400V maximum input high voltage. It is possible to create voltages in excess of 400V by driving an open cable or by generating $L di/dt$ spikes.

From transmission line theory it is known that a voltage pulse launched onto an open cable will cause the voltage to reflect back down the cable and double in amplitude. This voltage doubling will over-voltage the MOSFET and lead to driver failure. Turning on the driver with the load disconnected or opening the load while the driver is operating may cause it to fail due to this voltage doubling effect.

$L di/dt$ spikes are created when current flowing through an inductor is interrupted (i.e. current is turned off). The amplitude of the resultant voltage spike is defined by the formula:

$$V = L di/dt,$$

where L is the circuit inductance, di is the current value at turn off and dt is the time it takes for the current to get to zero (i.e. fall time). By monitoring the voltage output of the driver, the user can measure L di/dt voltage spikes. With this measurement, the user can determine the actual voltage across the MOSFET switching device, with the formula:

$$V_{\max} = [L \text{ di/dt}] + V_{\text{supply}}$$

where

L di/dt = peak of the negative-going spike;
V_{supply} = panel meter voltage;
V_{max} = 400 volts.

Any time the test setup (e.g. interconnect cables and/or load resistance) is changed, it will be necessary to again verify that V_{max} is no greater than 950 volts.

APPENDIX

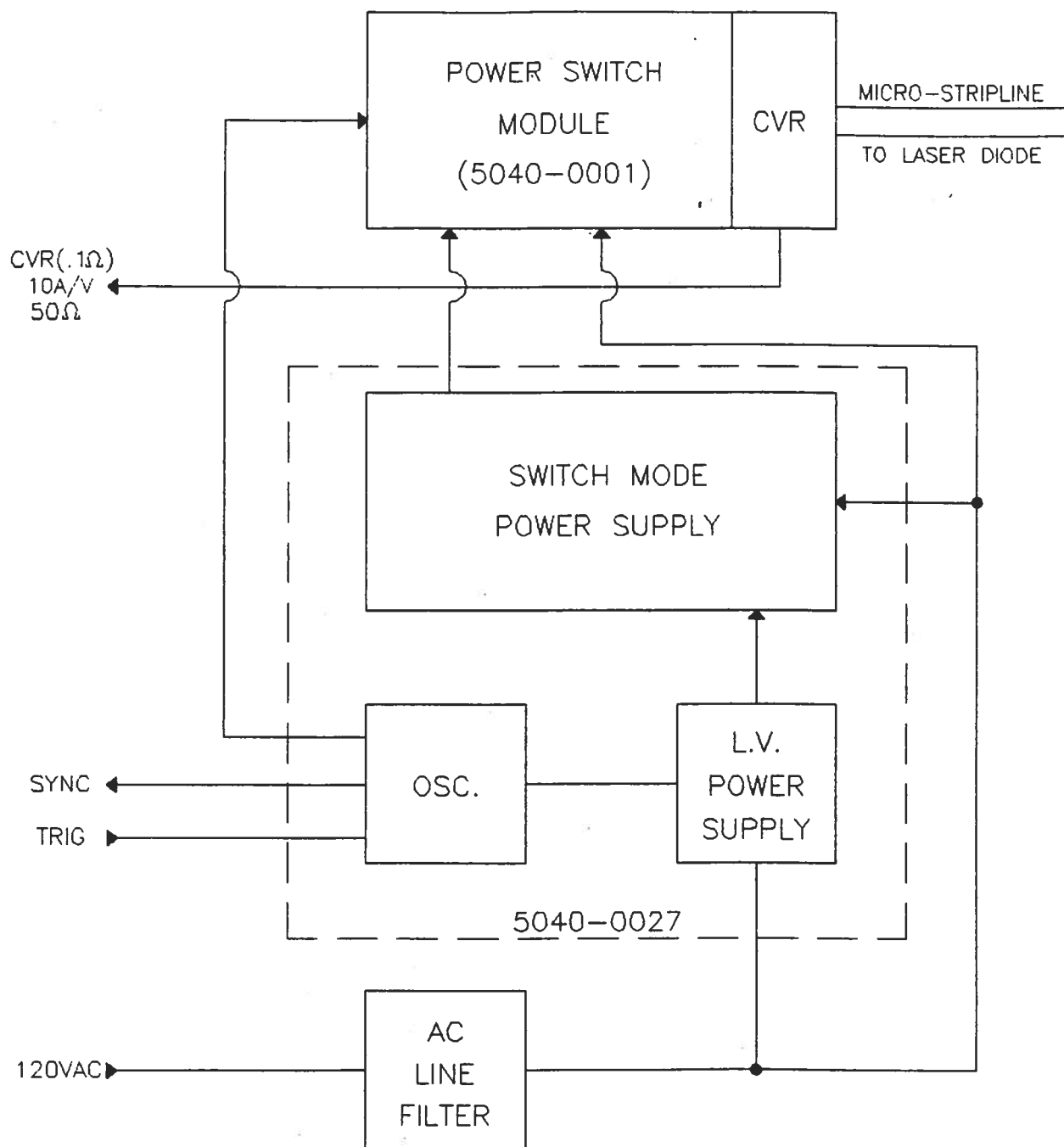

FIGURE 1.
LASER DIODE DRIVER
BLOCK DIAGRAM

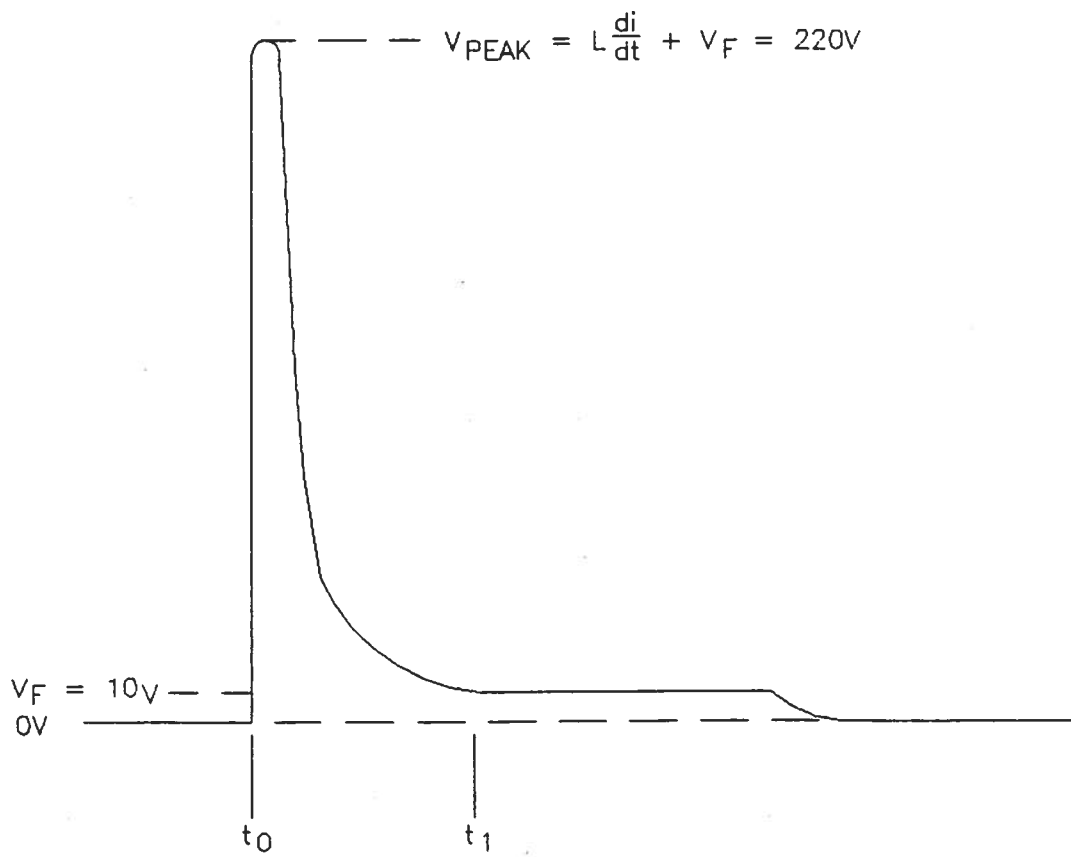
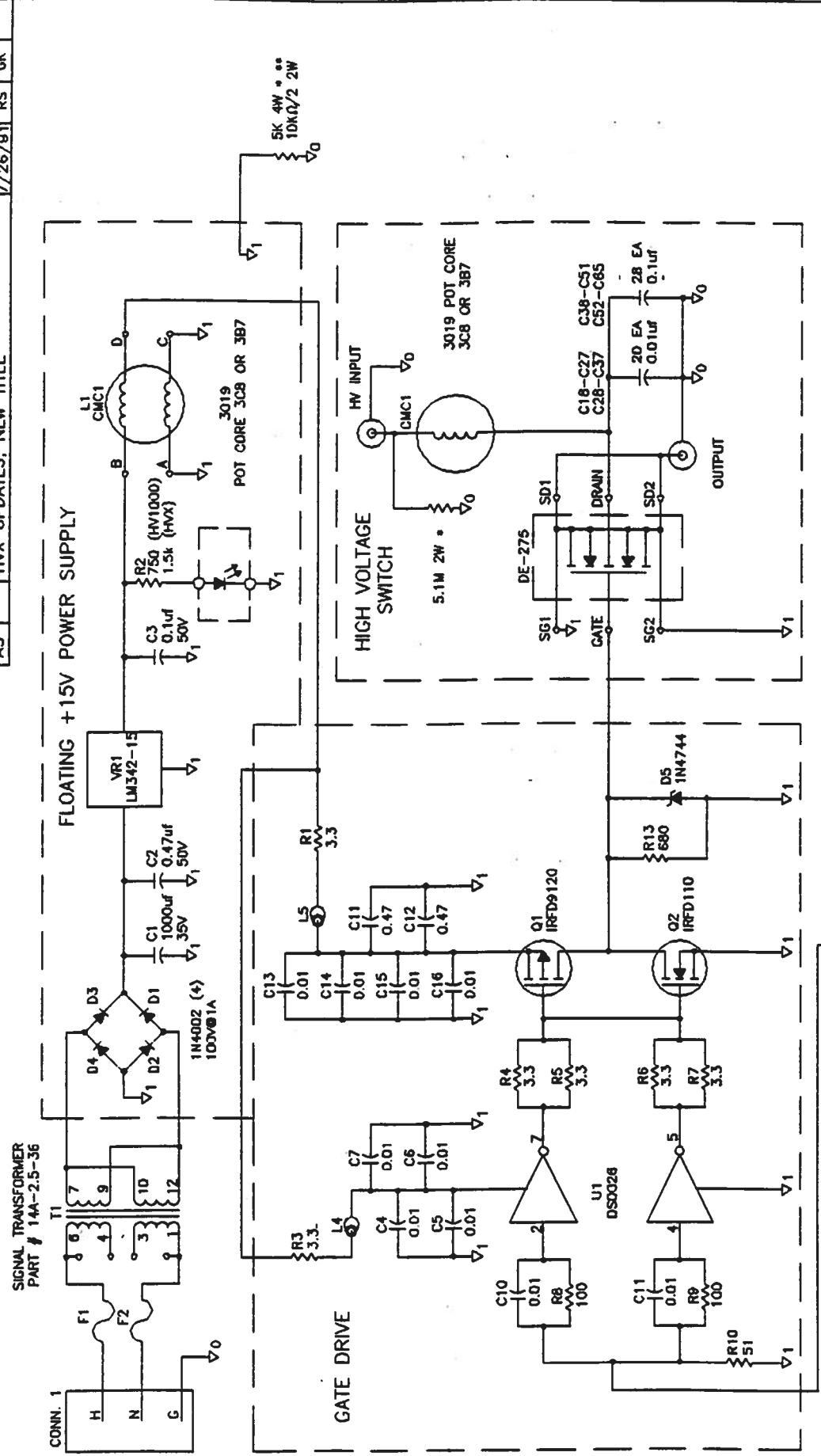
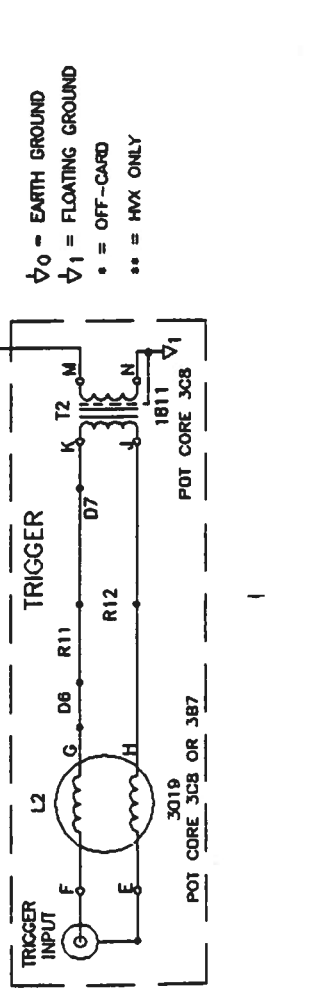

FIGURE 2.
 $V_{FORWARD}$ AS A
FUNCTION OF TIME

REV	EC	DESCRIPTION	DATE	BY	CHKD	ENG
01	-	ORIGINAL ISSUE				
A2	-	COMPONENT UPDATES	3/21/91	RS	GK	
A3	-	HVX UPDATES, NEW TITLE	7/26/91	RS	GK	



CONTRACT NO.		TITLE		SIZE	FCSM NO.	DWG NO.	REV
DRAWN	CADEC SERVICES	DATE	2/5/90	A		6040-0001	A3
CHECK	R.D. SHERWOOD	DATE	2/12/90				
DESIGN							
DESIGN ACTIVITY							
CUSTOMER							



V0 = EARTH GROUND
 V1 = FLOATING GROUND
 * = OFF-CARD
 ** = HVX ONLY

REV	EC	DESCRIPTION	DATE	BY	CHKD	ENG
D1	-	ORIGINAL ISSUE				
A2	-	COMPONENT UPDATES	3/21/91	RS	GK	GK
A3	-	HVX UPDATES, NEW TITLE	7/26/91	RS	GK	GK

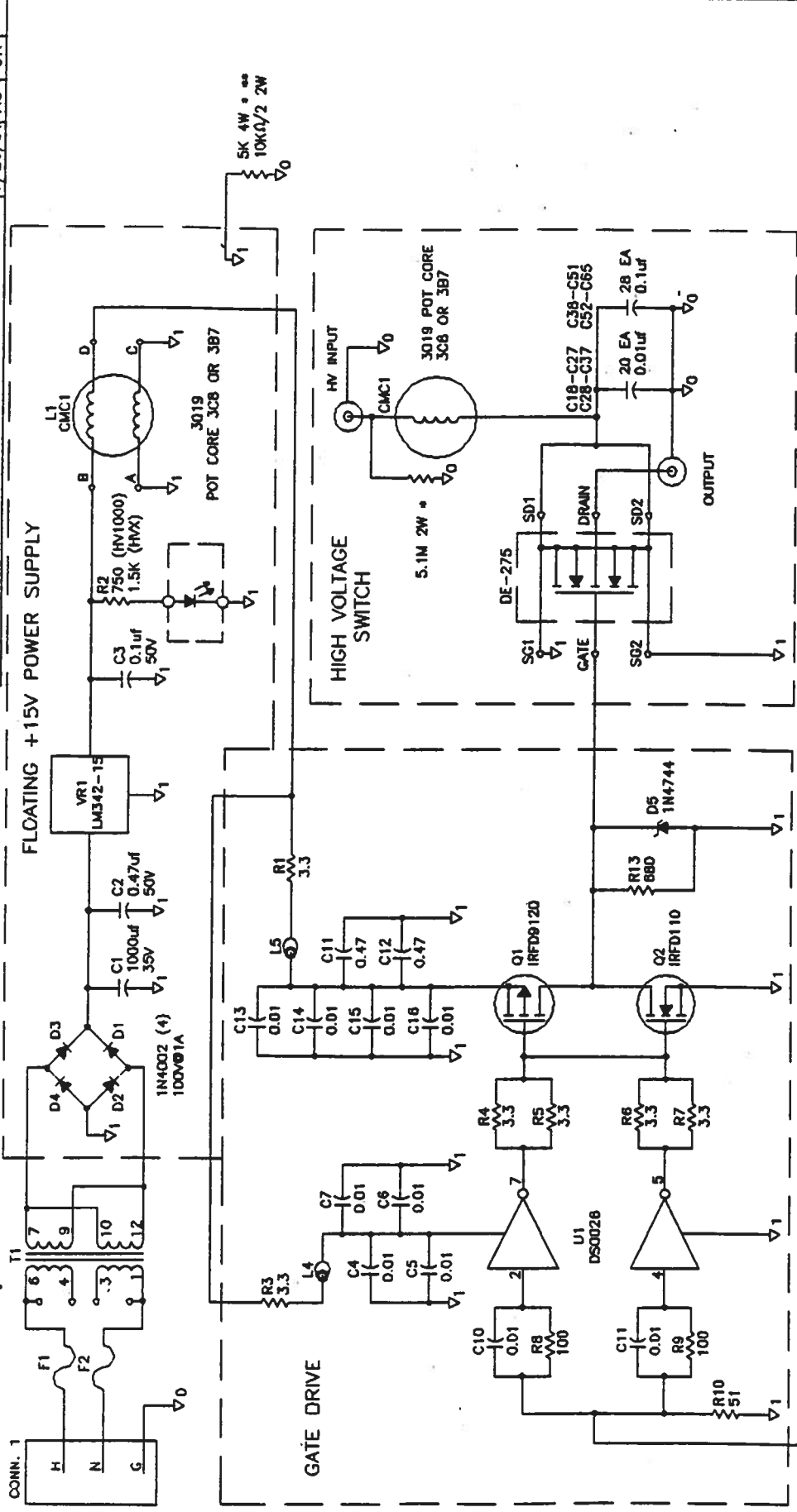

∇0 = EARTH GROUND
 ∇1 = FLOATING GROUND
 * = OFF-CARD
 ∞ = HVX ONLY

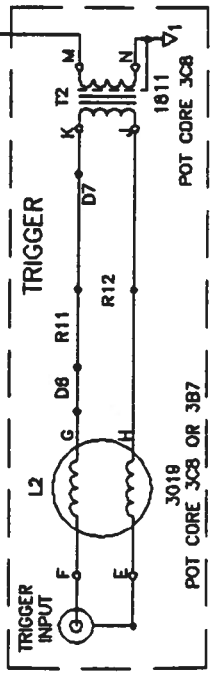

CONTRACT NO.		TITLE	
DRAWN	DATE	HV1000/HVX NEGATIVE PULSE MODULE SCHEMATIC	
CADCEC SERVICES	2/5/80	SIZE	A
CHECK	R.D. SHERWOOD	FCSM NO.	6040-0002
DESIGN	2/12/90	REV	A3
DESIGN ACTIVITY		RELEASE DATE	
CUSTOMER		SCALE	SHEET 1 OF 1

REV	EC	DESCRIPTION	DATE	BY	CHKD	ENG
A1	-	ORIGINAL ISSUE	10/05/90			
A2	-	UPDATE TITLE, R27 VALUE AND R35 VALUE	08/01/91	RS	GK	GK

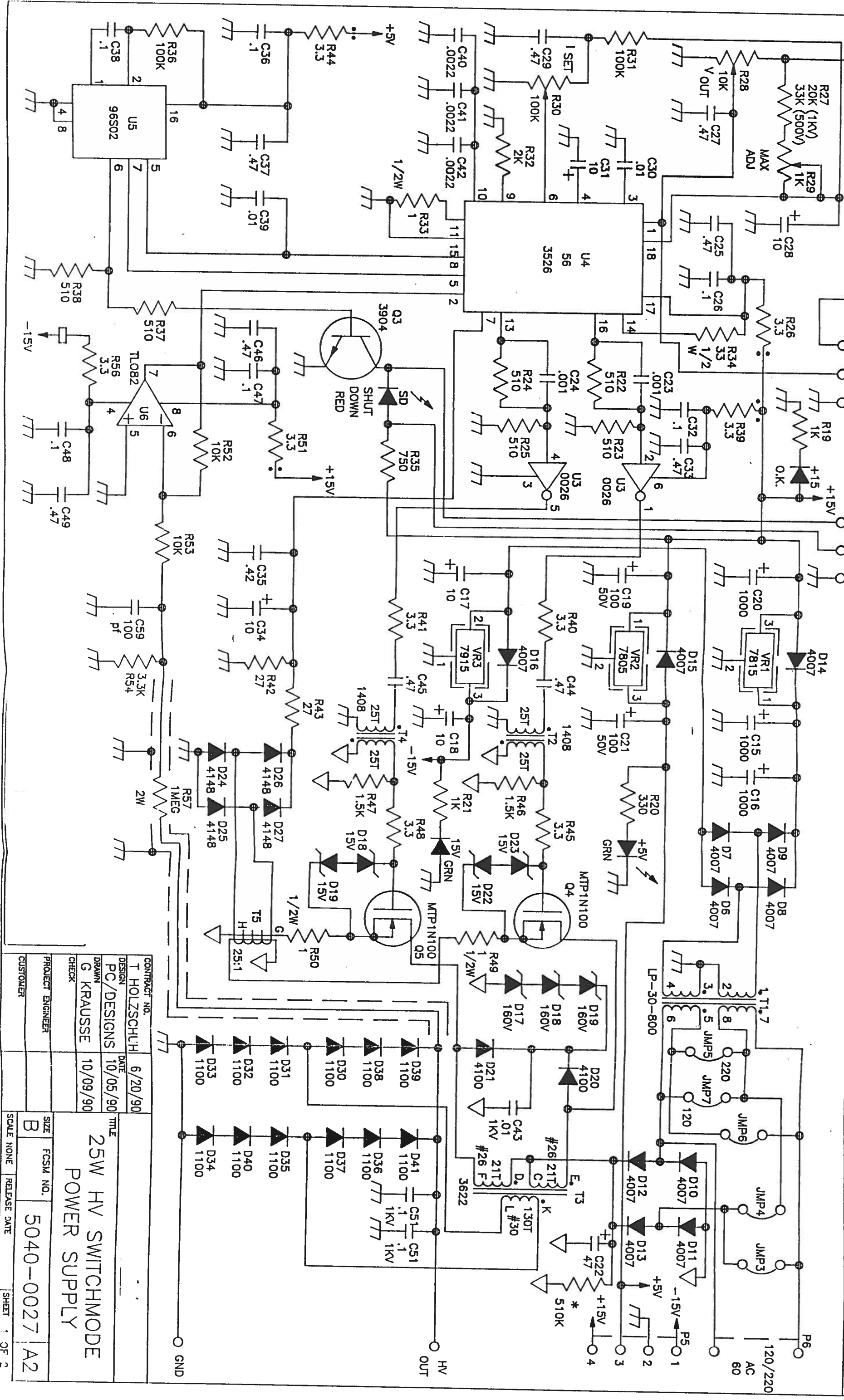

CONTRACT NO.	T. HOLZSCHULH	DATE	6/20/90
DESIGN	PC/DESIGNS	DATE	10/05/90
DRAWN	G. KRAUSSE	DATE	10/09/90
CHECK			
PROJECT ENGINEER			
CUSTOMER			
SCALE	NONE	RELEASE DATE	
SHEET	1	OF	2

**25W HV SWITCHMODE
POWER SUPPLY**

SIZE B FCSM NO. 5040-0027 A2

REV	EC	DESCRIPTION	DATE	BY	CHKD	ENG
A1	-	ORIGINAL ISSUE	10/05/90			
A2	-	UPDATE TITLE, C1, C2, D1, R2, R3, R4	09/01/91	RS	GK	GK

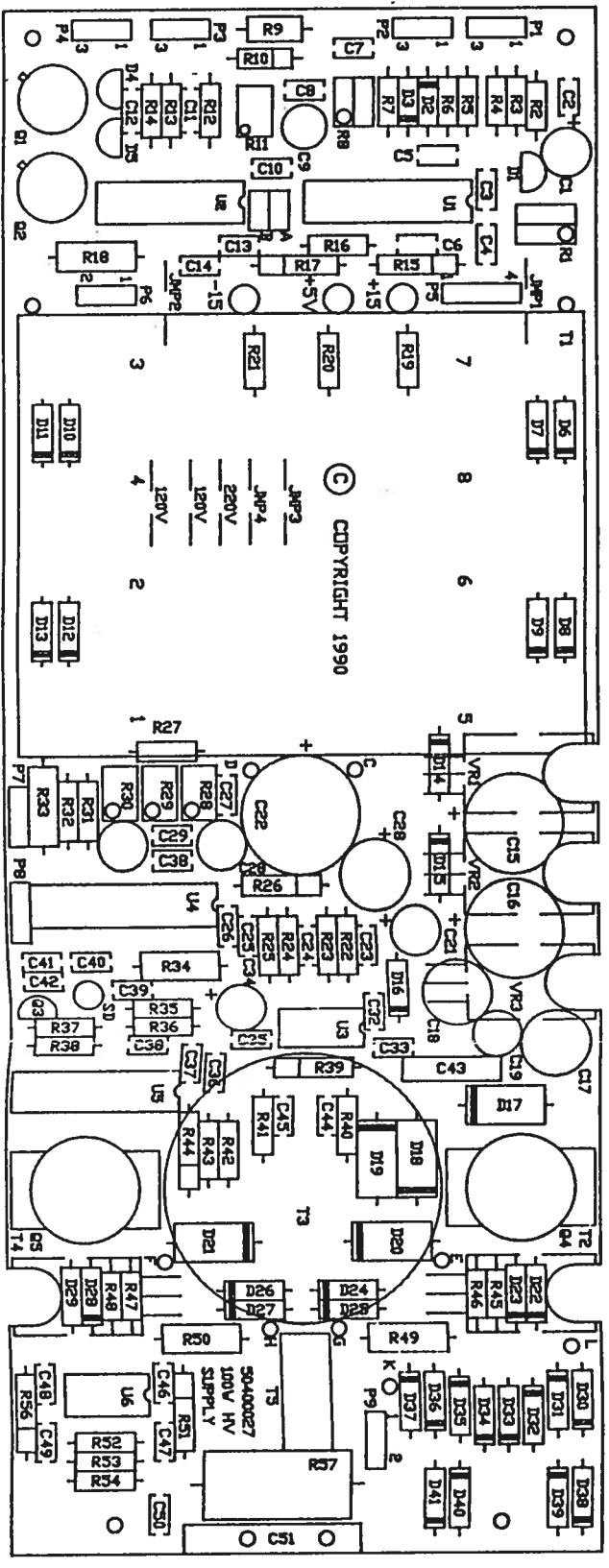
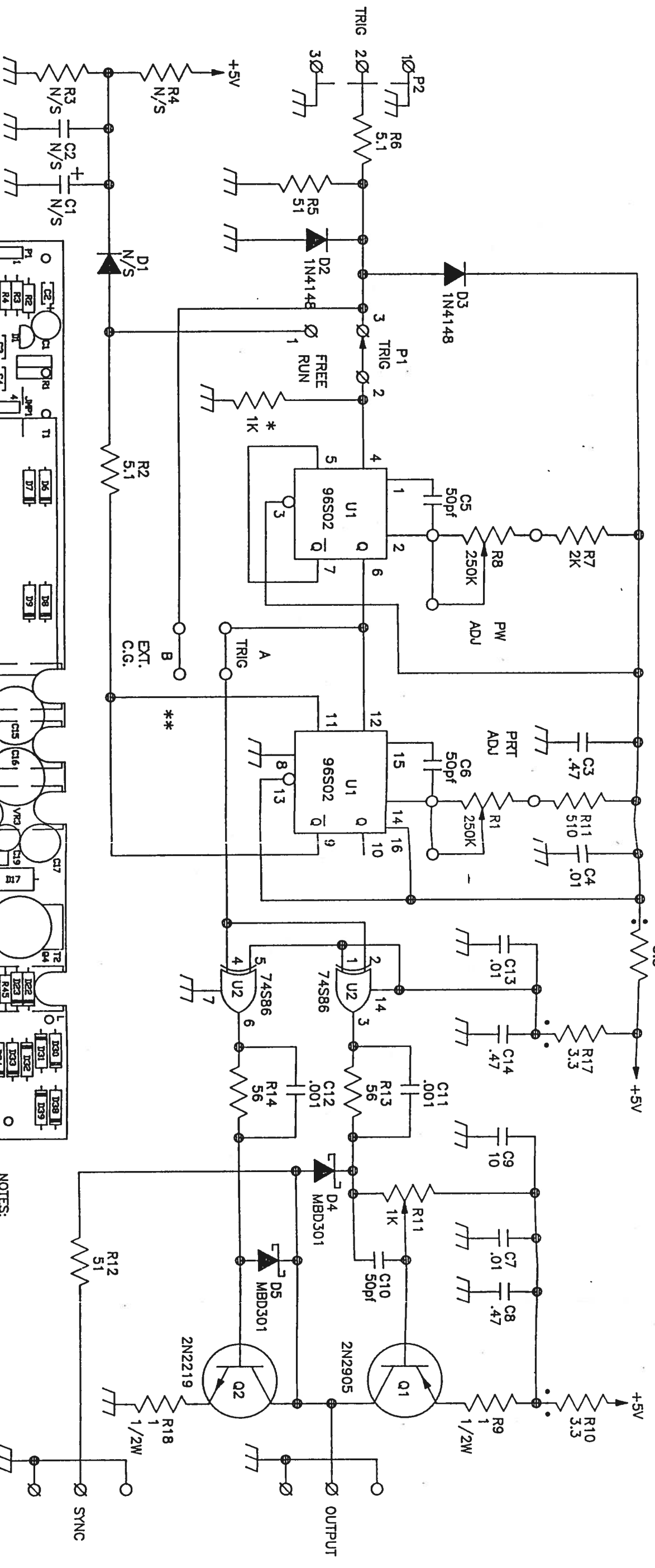

- NOTES:
(UNLESS OTHERWISE SPECIFIED)
1. ALL RESISTOR VALUES ARE IN OHMS.
 2. ALL RESISTORS ARE 1/4 W.
 3. ALL CAPACITOR VALUES ARE IN MICROFARADS.
 4. * ON BACK SIDE OF CARD.
 5. ** ADD.
 6. O ON-CARD / OFF-CARD.
 7. Ø OFF CARD.
 8. N/S = NOT STUFFED

SILK SCREEN

DESIGN	T HOLZSCHUH	DATE	6/20/90	TITLE	25W HV SWITCHMODE
DRAWN	PC/DESIGNS	DATE	10/05/90		PULSE GENERATOR
CHECK	G KRAUSSE	DATE	10/09/90	SIZE	B
PROJECT ENGINEER				FCSM NO.	5040-0027
CUSTOMER				SCALE NONE	RELEASE DATE
					SHEET 2 OF 2