



AVTECH ELECTROSYSTEMS LTD.

NANOSECOND WAVEFORM ELECTRONICS
SINCE 1975

P.O. BOX 265
OGDENSBURG, NY
U.S.A. 13669-0265
TEL: (315) 472-5270
FAX: (613) 226-2802

TEL: 1-800-265-6681
FAX: 1-800-561-1970

e-mail: info@avtechpulse.com
<http://www.avtechpulse.com>

P.O. BOX 5120 STN. F
OTTAWA, ONTARIO
CANADA K2C 3H4
TEL: (613) 226-5772
FAX: (613) 226-2802

INSTRUCTIONS

MODEL AV-1000-C

0 TO ± 10 VOLTS, 50 MHz
GENERAL PURPOSE PULSE GENERATOR

SERIAL NUMBER: _____

WARRANTY

Avtech Electrosystems Ltd. warrants products of its manufacture to be free from defects in material and workmanship under conditions of normal use. If, within one year after delivery to the original owner, and after prepaid return by the original owner, this Avtech product is found to be defective, Avtech shall at its option repair or replace said defective item. This warranty does not apply to units which have been disassembled, modified or subjected to conditions exceeding the applicable specifications or ratings. This warranty is the extent of the obligation assumed by Avtech with respect to this product and no other warranty or guarantee is either expressed or implied.

TECHNICAL SUPPORT

Phone: 613-226-5772 or 1-800-265-6681

Fax: 613-226-2802 or 1-800-561-1970

E-mail: info@avtechpulse.com

World Wide Web: <http://www.avtechpulse.com>

TABLE OF CONTENTS

| | |
|--|----|
| <i>WARRANTY</i> | 2 |
| <i>TECHNICAL SUPPORT</i> | 2 |
| <i>TABLE OF CONTENTS</i> | 3 |
| <i>INTRODUCTION</i> | 5 |
| <i>SPECIFICATIONS</i> | 6 |
| <i>INSTALLATION</i> | 7 |
| VISUAL CHECK | 7 |
| PLUGGING IN THE INSTRUMENT | 7 |
| <i>FRONT PANEL CONTROLS</i> | 9 |
| <i>REAR PANEL CONTROLS</i> | 13 |
| <i>GENERAL INFORMATION</i> | 14 |
| BASIC PULSE CONTROL | 14 |
| TRIGGER MODES | 16 |
| GATING MODES | 17 |
| <i>MINIMIZING WAVEFORM DISTORTIONS</i> | 18 |
| USE 50Ω TRANSMISSION LINES | 18 |
| USE LOW-INDUCTANCE LOADS | 18 |
| WHEN DRIVING A 50 OHM LOAD | 18 |
| WHEN DRIVING HIGH IMPEDANCE LOADS | 19 |
| <i>MECHANICAL INFORMATION</i> | 20 |
| TOP COVER REMOVAL | 20 |
| RACK MOUNTING | 20 |
| ELECTROMAGNETIC INTERFERENCE | 20 |
| <i>OPERATIONAL CHECK</i> | 21 |
| <i>TYPICAL WAVEFORMS</i> | 24 |
| TYPICAL RISE/FALL TIMES | 24 |
| ADJUSTABLE RISE/FALL TIMES | 24 |
| 50 MHz OPERATION | 25 |
| <i>REPAIR INSTRUCTIONS</i> | 26 |
| BLOWN AC FUSE | 26 |

| | |
|---------------------------------------|-----------|
| BURN-OUT POWER SWITCH LIGHT | 26 |
| DAMAGED MAIN OUTPUT | 26 |
| <i>PERFORMANCE CHECK SHEET</i> | 27 |

Manual Reference: Q:\office\instructword\av-1000\AV-1000-edc.DOC, created April 11, 2002

INTRODUCTION

The Avtech AV-1000-C is a versatile, general-purpose, low-cost, 50 MHz laboratory pulse generator, useful everywhere from undergraduate university classrooms to the most advanced research and development laboratories. This pulse generator features variable pulse repetition frequency (PRF), delay, pulse width, rise and fall times, amplitude, and baseline.

The generator can be triggered internally or externally, or by the manual "Single Pulse" pushbutton. All trigger sources can be gated by a TTL-type pulse. The internal trigger is continuously variable from 1 Hz to 50 MHz. The delay and pulse width are variable up to 1 second. The amplitude and baseline offset are variable from 0 to $\pm 10\text{V}$. Rise and fall times are independently variable (within a given range) from less than 5ns to 1ms.

The main output has all of its characteristics variable, and is designed to drive 50Ω loads. Four logic outputs (TTL, ECL, and their complements) have the same timing characteristics as the main output, but have non-adjustable rise and fall times, and have their amplitudes fixed at standard logic levels.

A synchronizing trigger output is also supplied, for triggering oscilloscopes and other test equipment (10 ns wide, +2V into 50Ω).

SPECIFICATIONS

| | |
|-----------------------------------|--|
| Model: | AV-1000-C |
| PRF: | 1 Hz to 50 MHz |
| Amplitude (to 50 Ohms): | Main output: 0 to ± 10 Volts (adjustable) TTL outputs (normal and inverted): low: 0 to +0.8V, high: +3 to +5V (fixed) ECL outputs (normal and inverted): low: -1.6V, high: -0.8V (fixed) |
| Pulse width: | 10 ns to 1.0 sec |
| Rise time, fall time: | Main: 5 ns to 1 ms, TTL: 5 ns, ECL: 2 ns |
| Jitter (Sync out to pulse out): | $\leq \pm 25$ ps $\pm 0.01\%$ of sync delay |
| DC offset: | ± 10 Volt range: 0 to ± 10 Volts. (Total output voltage can not exceed ± 10 V.) ± 1 , ± 5 Volt ranges: 0 to ± 5 Volts. |
| Source impedance (main output): | 50 Ohms (± 1 and ± 5 Volt ranges) 2 Ohms (± 10 Volt range) |
| Polarity (main output): | Positive or negative (switch-selectable) |
| Duty cycle (max): | PRF ≤ 10 MHz: 80%, ≤ 40 MHz: 60%, 50 MHz: 40% |
| Waveform aberrations: | Overshoot, undershoot, and ringing are $< \pm 5\%$ at amplitudes of > 300 mV, with outputs terminated in 50 Ω . |
| Trigger required (Ext trig mode): | TTL levels (low: 0 to +0.8V, high: +3 to +5V), 4 ns or wider. 1k Ω input impedance. |
| Trigger required (Gate in): | 0 to +0.8 V (or grounded): No output +3V to +5 V (or open): Normal output |
| Propagation delay: | < 75 ns (Ext trig in to main out, with sync delay set to minimum) |
| Sync delay: | ± 25 ns to ± 1.0 sec (Sync out to main out) |
| Sync output: | +3 Volts, 10 ns, will drive 50 Ohm loads |
| Single pulse mode: | manual push-button |
| Signal connectors: | BNC |
| Power requirement: | 120/240 Volts (switchable), 50 - 60 Hz |
| Dimensions (H x W x D): | 100 mm x 430 mm x 375 mm (3.9" x 17" x 14.8") |
| Weight & chassis material: | 4.5 kg (10 lbs), anodized aluminum, with blue plastic trim |
| Mounting & Temperature range: | Any, +10° C to +40° C |

INSTALLATION

VISUAL CHECK

After unpacking the instrument, examine to ensure that it has not been damaged in shipment. Visually inspect all connectors, knobs, and handles. Confirm that a power cord is with the instrument. If the instrument has been damaged, file a claim immediately with the company that transported the instrument.

PLUGGING IN THE INSTRUMENT

Examine the rear of the instrument. There will be a male power receptacle, a fuse holder and the edge of the power selector card visible. Confirm that the power selector card is in the correct orientation.

For AC line voltages of 110-120V, the power selector card should be installed so that the "120" marking is visible from the rear of the instrument, as shown below:

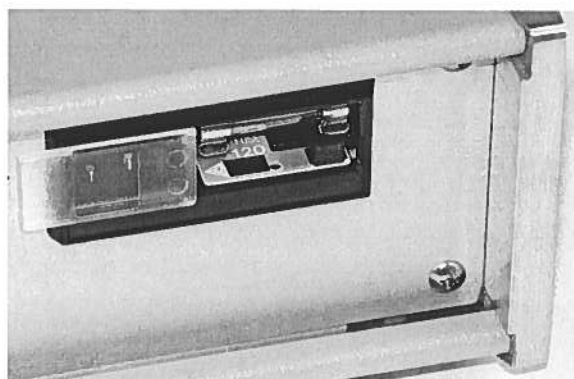

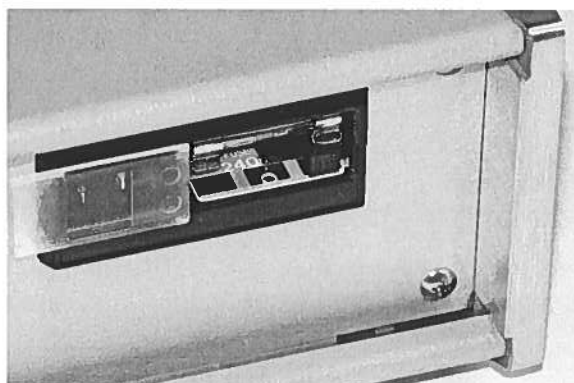

For AC line voltages of 220-240V, the power selector card should be installed so that the "240" marking is visible from the rear of the instrument, as shown below:





If it is not set for the proper voltage, remove the fuse and then grasp the card with a pair of pliers and remove it. Rotate horizontally through 180 degrees. Reinstall the card and the correct fuse.

In the 120V setting, a 1.0A slow blow fuse is required. In the 240V setting, a 0.5A slow blow fuse is required.



FRONT PANEL CONTROLS

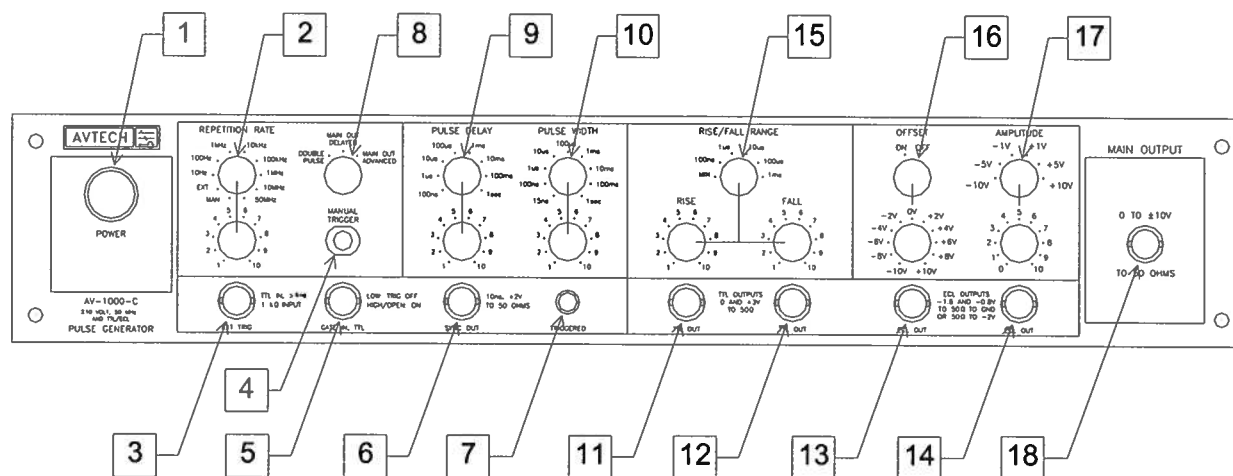

1. **POWER Switch.** The POWER push button switch applies AC prime power to the primaries of the transformer, turning the instrument on. The push button lamp (#382 type) is connected to the internal +15V DC supply.
2. **REPETITION RATE Controls.** This switch sets the triggering mode for the instrument.

In the "MAN" position, the instrument is triggered by the "Manual Trigger" pushbutton (item 4).

In the "EXT" position, the instrument is triggered by externally-generated TTL-level (0 and 3-5V logic levels) pulses on the "EXT TRIG" input connector (item 3).

The remaining positions serve as decade-range controls for the internal oscillator, which triggers the instrument in these positions. The vernier control immediately below the switch provides continuous adjustment of the frequency within each decade range.

3. **EXT TRIG Connector.** When the REPETITION RATE switch (item 2) is set to the "EXT" position, a TTL-level pulse applied to this input will trigger the instrument. The instrument triggers on the rising edge of this input. The input impedance of this input is 1 k Ω . (Depending on the length of cable attached to this input, and the source driving it, it may be desirable to add a coaxial 50 Ohm terminator to this input to provide a proper transmission line termination. The Pasternack (www.pasternack.com) PE6008-50 BNC feed-thru 50 Ohm terminator is suggested for this purpose.)

4. MANUAL TRIGGER Pushbutton. When the REPETITION RATE switch (item 2) is set to the "MAN" position, the instrument is triggered by pressing this pushbutton. A single trigger event occurs for each press of the pushbutton.
5. GATE IN Connector. This TTL-level (i.e., 0 and 3-5V logic levels) input gates the trigger. If this input is unconnected or TTL-high (3 to 5V), the instrument will trigger normally. If this input is TTL-low (0 Volts), triggering is inhibited.
6. SYNC OUT Connector. This output generates a 10 ns wide TTL-level pulse for each trigger event. This output can be used to trigger an oscilloscope, or other test equipment.

The PULSE DELAY controls (item 9) and DELAY MODE switch (item 8) affect the operation of this output. When the DELAY MODE switch is in the "Main Out Delayed" position, the pulses on the main output (item 18) and the four logic outputs (items 11-14) are delayed relative to the SYNC OUT pulse by a time controlled by the PULSE DELAY controls (item 9).

When the DELAY MODE switch is in the "Main Out Advanced" position, the pulses on the main output (item 18) and the four logic outputs (items 11-14) are advanced relative to the SYNC OUT pulse by a time controlled by the PULSE DELAY controls (item 9).

When the DELAY MODE switch is in the "Double Pulse" position, the SYNC OUT pulse is approximately coincident with the first pulse of the pair of pulses on the main output.

For this output to operate correctly, the delay setting must be less than the period.

7. TRIGGERED Indicator. This indicator is lit when pulses are detected on the logic outputs (items 11 to 14), and it gives an indication that the timing parameters have been set properly and do not conflict.

If this indicator is not lit, it suggests that instrument is not triggering, or that the delay or pulse width settings exceed the pulse period.

8. DELAY MODE Switch. This switch determines the function of the PULSE DELAY controls (item 9). When this switch is set in the "DOUBLE PULSE" position, the main output (item 18) and the logic outputs (items 11-14) generate a pair of pulses in response to each trigger event. The DELAY controls determine the spacing between the first and second pulses in the pair. The SYNC OUT pulse is approximately coincident with the first pulse of the pair of pulses on the main output.

When the DELAY MODE switch is in the "Main Out Delayed" position, the pulses on the main output (item 18) and the four logic outputs (items 11-14) are delayed relative to the SYNC OUT pulse by a time controlled by the PULSE DELAY controls

(item 9). The SYNC OUT pulse itself is generated after a minimal delay relative to the trigger source. (This is the most common mode of operation.)

When the DELAY MODE switch is in the "Main Out Advanced" position, the pulses on the main output (item 18) and the four logic outputs (items 11-14) are approximately coincident with the trigger event, and the SYNC output is delayed relative to the main output and logic outputs by a time controlled by the PULSE DELAY controls (item 9).

9. PULSE DELAY Controls. This decade range switch, and the vernier control immediately below, control the separation between the main and logic outputs (items 11-14 and 18) and the SYNC OUT output (item 6).
10. PULSE WIDTH Controls. This decade range switch, and the vernier control immediately below, control the pulse width of the main and logic outputs (items 11-14 and 18).
11. TTL OUT Connector. This output provides a TTL-level pulse (quiescent level: 0V, pulse level: 3-5V) whose triggering, delay, and pulse width are controlled by the front-panel controls. The amplitude and rise and fall times are fixed. This output will drive impedances of 50 Ohms or greater. To minimize distortion, this output should ideally be connected using 50 Ohm coaxial cabling, and terminated with a 50 Ohm load.
12. NOT-TTL OUT Connector. This output provides an inverted TTL-level pulse (quiescent level: 3-5V, pulse level: 0V) whose triggering, delay, and pulse width are controlled by the front-panel controls. This output is the logical complement of the TTL OUT output (item 11). This output will drive impedances of 50 Ohms or greater. To minimize distortion, this output should ideally be connected using 50 Ohm coaxial cabling, and terminated with a 50 Ohm load.
13. ECL OUT Connector. This output provides an ECL-level pulse (quiescent level: -1.6V, pulse level: -0.8V) whose triggering, delay, and pulse width are controlled by the front-panel controls. The amplitude and rise and fall times are fixed. This output will drive a load of 50 Ohms or greater, connected to ground or to -2V. To minimize distortion, this output should ideally be connected using 50 Ohm coaxial cabling, and terminated with a 50 Ohm load.
14. NOT-TTL OUT Connector. This output provides an inverted ECL-level pulse (quiescent level: -0.8V, pulse level: -1.6V) whose triggering, delay, and pulse width are controlled by the front-panel controls. This output is the logical complement of the ECL OUT output (item 13). This output will drive a load of 50 Ohms or greater, connected to ground or to -2V. To minimize distortion, this output should ideally be connected using 50 Ohm coaxial cabling, and terminated with a 50 Ohm load.

15. RISE/FALL TIME Controls. These controls determine the rise and fall time of the pulse on the main output (item 18). The rise and fall time vernier controls may be independently adjusted, but the decade range switch is common to both.
16. OFFSET Controls. When the OFFSET ON/OFF switch is set to "ON", the dial immediately below the switch controls the baseline of the main output. The offset may be varied between -10 and +10V when operating in the +10 or -10V amplitude ranges. (The maximum offset is proportionately less in the other amplitude ranges.) The offset feature may be disabled by setting the OFFSET ON/OFF switch to "OFF". The baseline offset is then fixed at zero Volts.
17. AMPLITUDE Controls. This range switch and vernier dial control the amplitude of the main output (item 18).

When the amplitude range is +10V or -10V, the output impedance is low (approximately 2 Ohms). This range provides for the highest amplitude, but no backmatching is provided, which may result in waveform distortion if the load is not 50 Ohms.

In the ± 1 and ± 5 V ranges, the output impedance is 50 Ohms. This provides backmatching for 50 Ohm transmission lines, which minimizes waveform distortions.

The best performance will be obtained when the lowest amplitude range consistent with the desired amplitude is used.

18. MAIN OUTPUT Connector. This is the main output. The amplitude and offset may be varied between -10V and +10V. The total output cannot exceed ± 10 V.

REAR PANEL CONTROLS



19. **AC POWER INPUT.** A three-pronged recessed male connector is provided on the back panel for AC power connection to the instrument. Also contained in this assembly is a slow blow fuse and a removable card that can be removed and repositioned to switch between 120V AC in and 240V AC in.

For AC line voltages of 110-120V, the power selector card should be installed so that the "120" marking is visible from the rear of the instrument.

For AC line voltages of 220-240V, the power selector card should be installed so that the "240" marking is visible from the rear of the instrument.

If it is not set for the proper voltage, remove the fuse and then grasp the card with a pair of pliers and remove it. Rotate horizontally through 180 degrees. Reinstall the card and the correct fuse.

In the 120V setting, a 1.0A slow blow fuse is required. In the 240V setting, a 0.5A slow blow fuse is required. See the "Installation" section for more details.

GENERAL INFORMATION

BASIC PULSE CONTROL

This instrument can be triggered by its own internal clock, by an external TTL trigger signal, or by the front-panel MANUAL TRIGGER pushbutton. In any case, six output channels respond to the trigger: MAIN OUTPUT, SYNC, TTL, NOT-TTL, ECL, and NOT-ECL. The MAIN OUTPUT channel is the signal that is normally applied to the load. Its amplitude and pulse width are variable. The SYNC pulse is a fixed-width TTL-level reference pulse used to trigger oscilloscopes or other measurement systems. When the delay is set to a positive value the SYNC pulse precedes the OUT pulse. When the delay is set to a negative value the SYNC pulse follows the OUT pulse.

The four logic outputs (TTL, NOT-TTL, ECL, and NOT-ECL) are approximately coincident with the main output, but have fixed amplitudes and rise and fall times.

These pulses are illustrated below, assuming that internal triggering is used, and the delay mode is set to "MAIN OUT DELAYED":

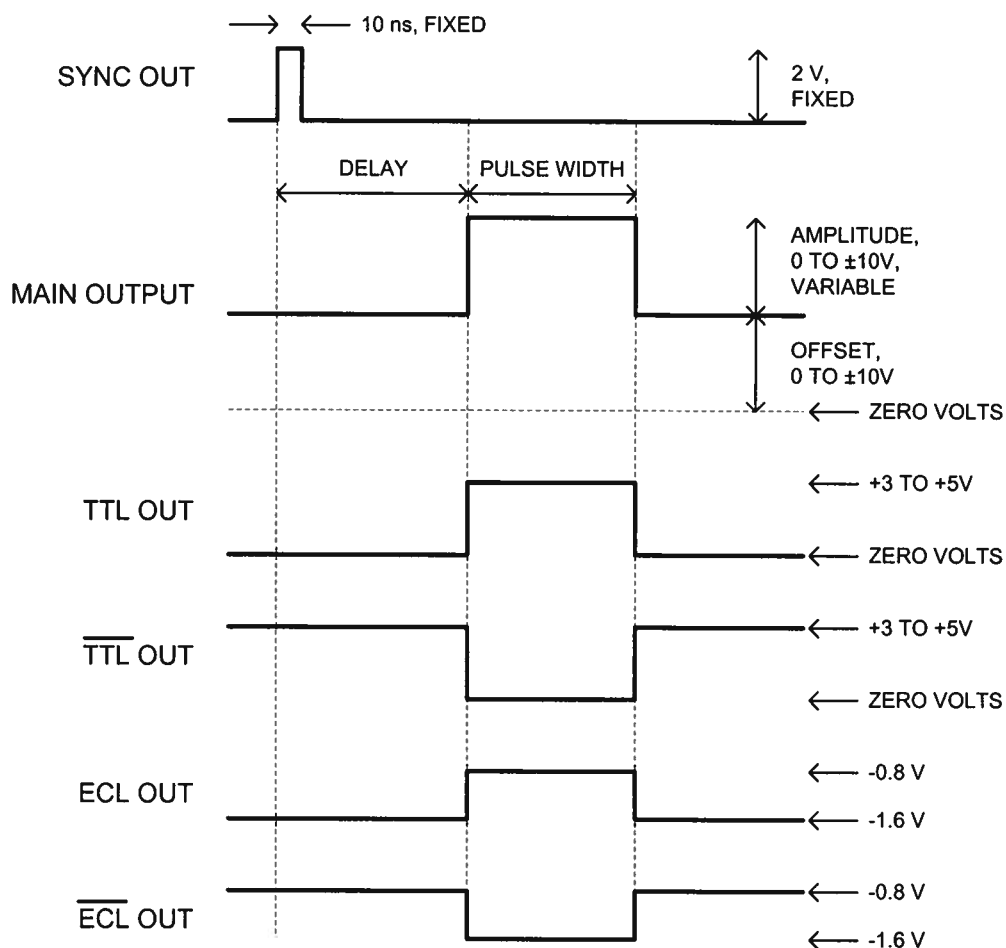

If the delay mode is set to "MAIN OUT ADVANCED", the order of the SYNC and OUT pulses is reversed:

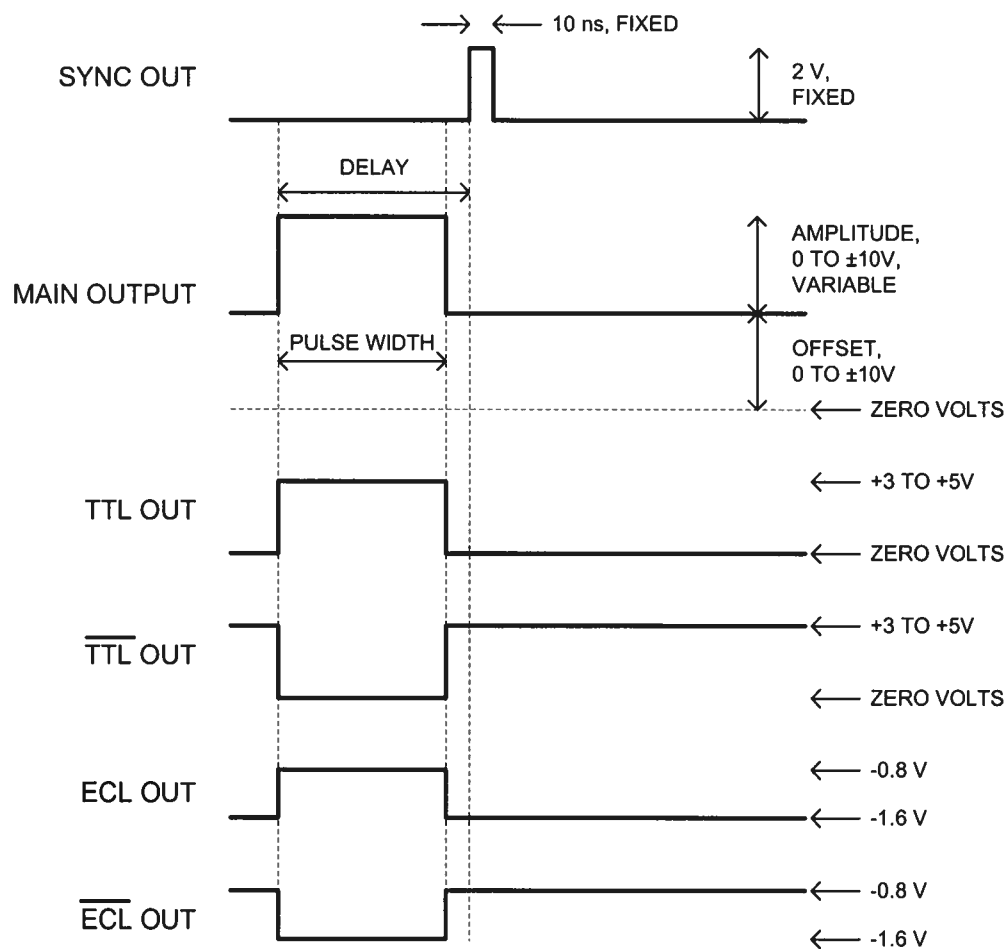

The next figure illustrates the relationship between the signals when an external TTL-level trigger is used (i.e., the REPETITION RATE switch is set to "EXT"), assuming that the delay mode is set to "MAIN OUT DELAYED":

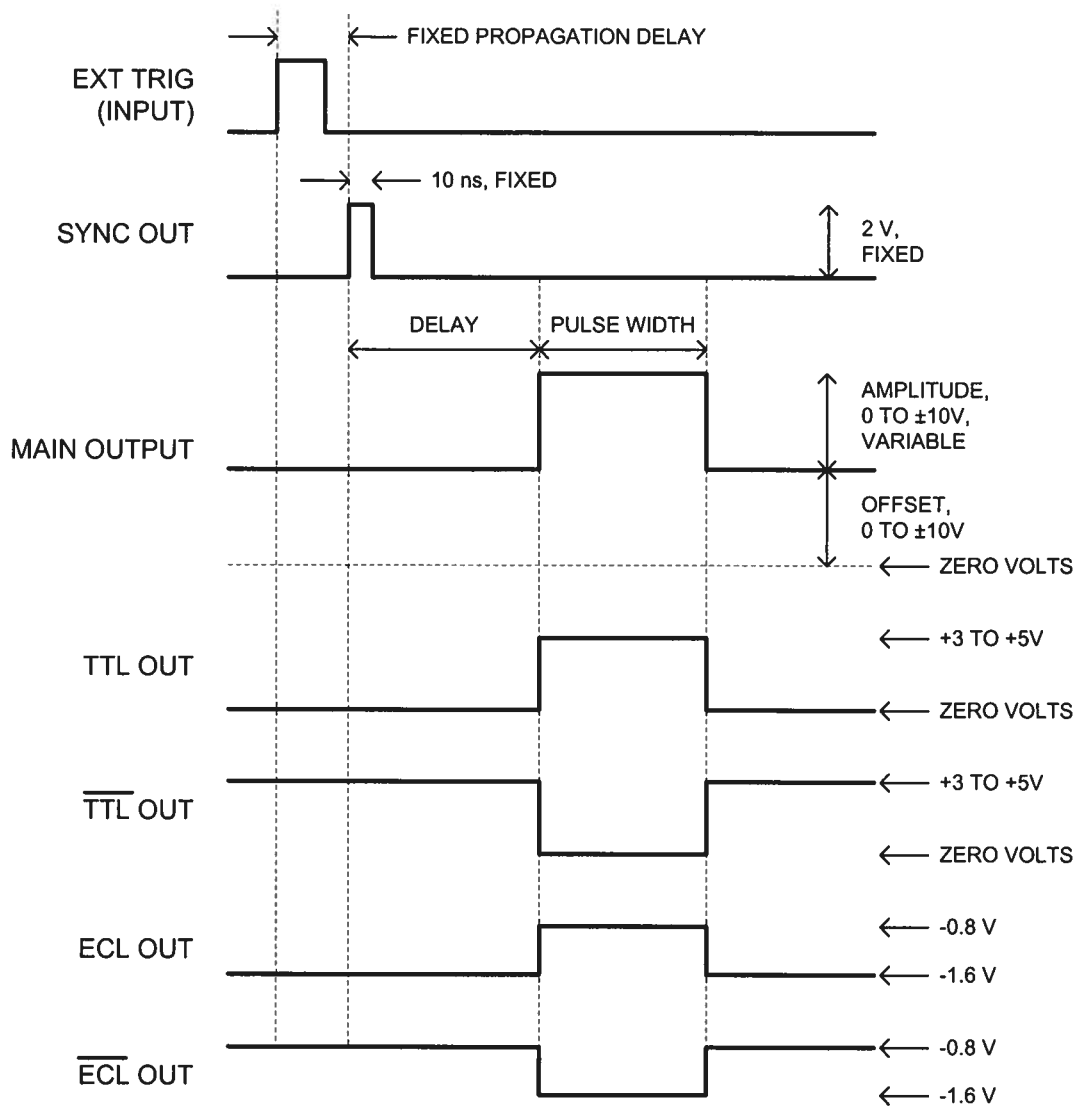

As before, if the delay mode is set to "MAIN OUT ADVANCED", the order of the SYNC and OUT pulses is reversed.

TRIGGER MODES

This instrument has three trigger modes:

- **Internal Trigger:** the instrument controls the trigger frequency, and generates the clock internally. This mode is enabled by setting the REPETITION RATE switch to one of the positions labeled with a frequency (i.e., 1kHz, 10 kHz, etc). The labeled frequency represents the upper end of that frequency range.

- External Trigger: the instrument is triggered by an external TTL-level clock on the EXT TRIG connector. This mode is enabled by setting the REPETITION RATE switch to the "EXT" position.
- Manual Trigger: the instrument is triggered by the front-panel "MANUAL TRIGGER" pushbutton. This mode is enabled by setting the REPETITION RATE switch to the "MAN" position.

GATING MODES

Triggering can be suppressed by a TTL-level signal on the GATE IN connector. If the GATE IN input is unconnected or TTL-high (3 to 5V), the instrument will trigger normally. If this input is TTL-low (0 Volts), triggering is inhibited.

MINIMIZING WAVEFORM DISTORTIONS

USE 50Ω TRANSMISSION LINES

Connect the load to the pulse generator with 50Ω transmission lines (e.g. RG-58 or RG-174 cable). If possible, use a 50Ω load. If the actual device under test has a high impedance, consider adding a 50Ω termination in parallel with the load to properly terminate the transmission line.

USE LOW-INDUCTANCE LOADS

Lenz's Law predicts that for an inductive voltage spike will be generated when the current through an inductance changes. Specifically, $V_{\text{SPIKE}} = L \times dI_{\text{LOAD}}/dt$, where L is the inductance, I_{LOAD} is the load current change, and t is time. For this reason, it is important to keep any parasitic in the load low. This means keeping wiring short, and using low inductance components. In particular, wire-wound resistors should be avoided.

WHEN DRIVING A 50 OHM LOAD

The output impedance of the main output is either 2Ω (for the ±10V ranges) or 50Ω (for the ±1 and ±5V ranges). Whenever possible, the ranges with 50Ω output impedance should be used, because the 50Ω impedance provides backmatching for the coaxial cable.

This concept is illustrated in the figure below. The ideal scenario, with the least waveform distortion due to transmission line reflections, occurs when both the output impedance and the load impedance are 50Ω. In this case, both ends of the coaxial cable transmission line are effectively terminated with 50Ω.

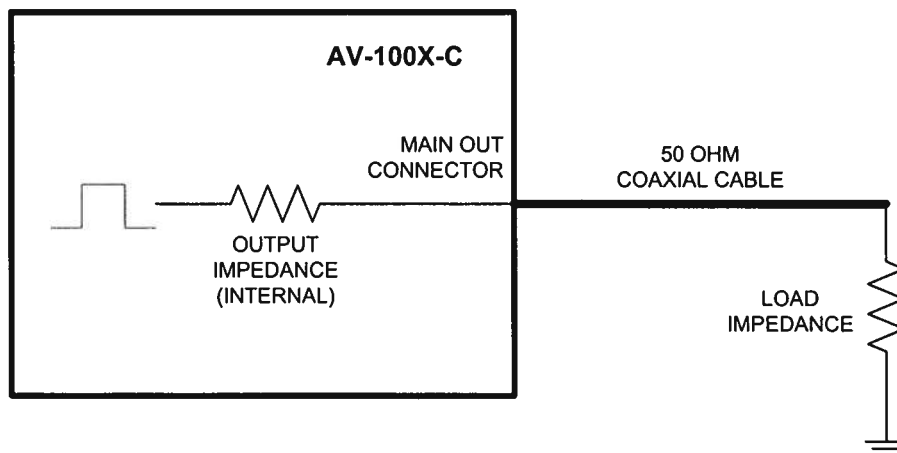

However, to obtain output amplitudes greater than $\pm 5\text{V}$, the $\pm 10\text{V}$ ranges must be used, and the output impedance will be 2Ω . This is slightly less ideal, but good waveforms will still be obtained since the transmission line is still properly terminated on one end (the load end) with 50Ω .

WHEN DRIVING HIGH IMPEDANCE LOADS

The ranges are labeled assuming operation into a 50 Ohm load. The $\pm 1\text{V}$ and $\pm 5\text{V}$ ranges will actually generate $\pm 2\text{V}$ and $\pm 10\text{V}$ respectively when driving a high impedance load ($\gg 50\Omega$). The $\pm 10\text{V}$ range capabilities are unchanged.

When driving a high impedance load (i.e., $R_L \gg 50\Omega$), using the $\pm 1\text{V}$ or $\pm 5\text{V}$ range amplitudes is recommended, since the 50Ω output impedance will provide a proper transmission line termination at the output end of the line, and the $\pm 5\text{V}$ range will actually provide the full $\pm 10\text{V}$ amplitude capability. The backmatching will minimize waveform ringing and transmission line reflections, without adversely affecting the pulse amplitude.

MECHANICAL INFORMATION

TOP COVER REMOVAL

The interior of the instrument may be accessed by removing the four Phillips screws on the top panel. With the four screws removed, the top cover may be slid back (and off).

RACK MOUNTING

A rack mounting kit is available. The -R5 rack mount kit may be installed after first removing the one Phillips screw on the side panel adjacent to the front handle.

ELECTROMAGNETIC INTERFERENCE

To prevent electromagnetic interference with other equipment, all used outputs should be connected to shielded 50 Ω loads using shielded 50 Ω coaxial cables. Unused outputs should be terminated with shielded 50 Ω BNC terminators or with shielded BNC dust caps, to prevent unintentional electromagnetic radiation. All cords and cables should be less than 3m in length.

OPERATIONAL CHECK

This check is to confirm that the instrument is fully functional. In all tests, use 50 Ω cable with female BNC connectors on each end. Set the controls to the following values:

REPETITION RATE RANGE Switch: 1 MHz

REPETITION RATE Vernier: fully clockwise (maximum)

PULSE DELAY Switch: 100ns

PULSE DELAY Vernier: fully counter-clockwise (minimum)

PULSE WIDTH Switch: 100ns

PULSE WIDTH Vernier: fully clockwise (maximum)

RISE/FALL RANGE Switch: MIN

RISE Vernier: fully counter-clockwise (minimum)

FALL Vernier: fully counter-clockwise (minimum)

OFFSET ON/OFF Switch: OFF

AMPLITUDE Switch: +10V

AMPLITUDE Vernier: fully clockwise (maximum)

As shown below, connect a 50 Ohm coaxial cable from the SYNC OUT connector to the TRIG input of an oscilloscope with a bandwidth of at least 200 MHz. Connect a low-inductance 50 Ohm, 2W resistor across the MAIN OUTPUT connector. (A BNC-to-banana post adapter may be used for this purpose. Keep the resistor leads as short as possible).

Set the oscilloscope to trigger externally. Then follow the instructions in the following table, and compare what is seen on the oscilloscope to what is described. Only approximate values are needed to confirm operation.

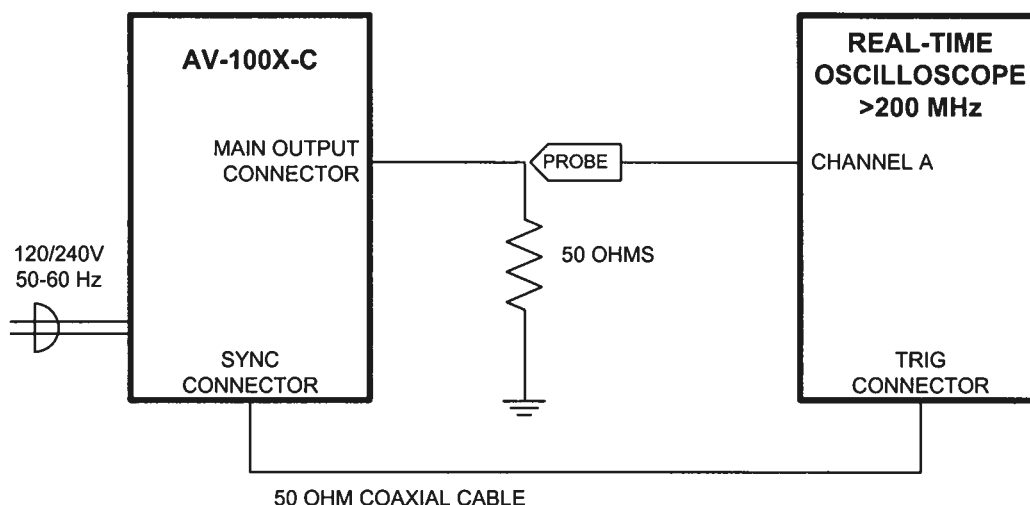

| STEP | CONTROL | OPERATION | RESULTS |
|------|-------------------------|--|--|
| 1 | POWER | Push in (ON) | +10V pulses at the main output, with period $1\mu\text{s}$, pulse width 100ns, <10ns rise and fall times. |
| 2 | REPETITION RATE VERNIER | Rotate to MIN (1), then to MAX (10) | Period rises to about $10\mu\text{s}$, then falls to about $1\mu\text{s}$. |
| 3 | DELAY VERNIER | Rotate to MAX, then to MIN | Pulses shift to the right on the oscilloscope by 100ns, then back. |
| 4 | PULSE WIDTH VERNIER | Rotate to MIN, then to MAX | Pulses become very narrow (about 10ns wide), then return to 100ns pulse width. |
| 5 | RISE VERNIER | Rotate to MAX, then to MIN | Rise time increases to 30ns, then decreases. |
| 6 | FALL VERNIER | Rotate to MAX, then to MIN | Fall time increases to 30ns, then decreases. |
| 7 | AMPLITUDE SWITCH | Switch to -10V, then to +10V | Pulses swing between 0 and -10V, then swing between 0 and +10V. |
| 8 | OFFSET ON/OFF SWITCH | Switch to ON | Pulses may shift up or down. |
| 9 | OFFSET VERNIER | Rotate to -10V | Pulses swing between -10V and 0V. |
| 10 | OFFSET ON/OFF SWITCH | Switch to OFF | Pulses swing between 0 and +10V. |
| 11 | AMPLITUDE SWITCH | Switch to +5V, then +1V, then back to +10V | Amplitude falls to +5V, then +1V, then rises back up to +10V. |
| 12 | TTL OUT | Remove cable from MAIN OUTPUT connector, place on TTL OUT connector. | Oscilloscope shows pulses swinging between 0V and +3V, with period $1\mu\text{s}$, and pulse width 100ns. |

| | | | |
|----|-------------|---|--|
| 13 | ECL OUT | Remove cable, place on ECL OUT connector | Oscilloscope shows pulses swinging between -0.8V and -1.6V, with period 1 μ s, and pulse width 100ns. |
| 14 | NOT TTL OUT | Remove cable from ECL OUT connector, place on NOT TTL OUT connector | Oscilloscope shows inverted pulses swinging between 0V and 3V, with period 1 μ s, and low time 100ns. |
| 15 | NOT ECL OUT | Remove cable from NOT TTL OUT connector, place on NOT ECL OUT connector | Oscilloscope shows inverted pulses swinging between -0.8V and -1.6V, with period 1 μ s, and pulse width 100ns. |

This completes the operational check.

TYPICAL WAVEFORMS

TYPICAL RISE/FALL TIMES

10 kHz repetition rate, 100 ns pulse width, +10V into a 50 Ohm load, with rise and fall times set to minimum:

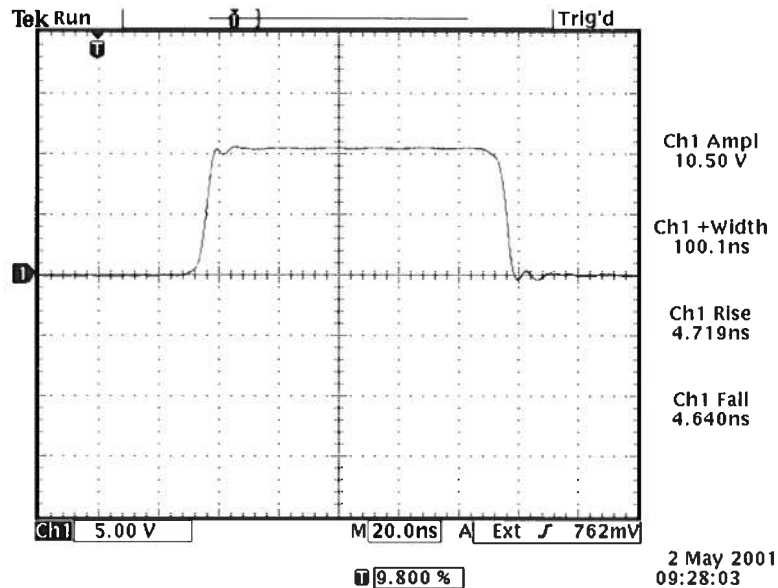

ADJUSTABLE RISE/FALL TIMES

10 kHz repetition rate, +10V into a 50 Ohm load, with rise/fall time range switch set to 1 us, and rise time vernier at minimum and fall time vernier at maximum:

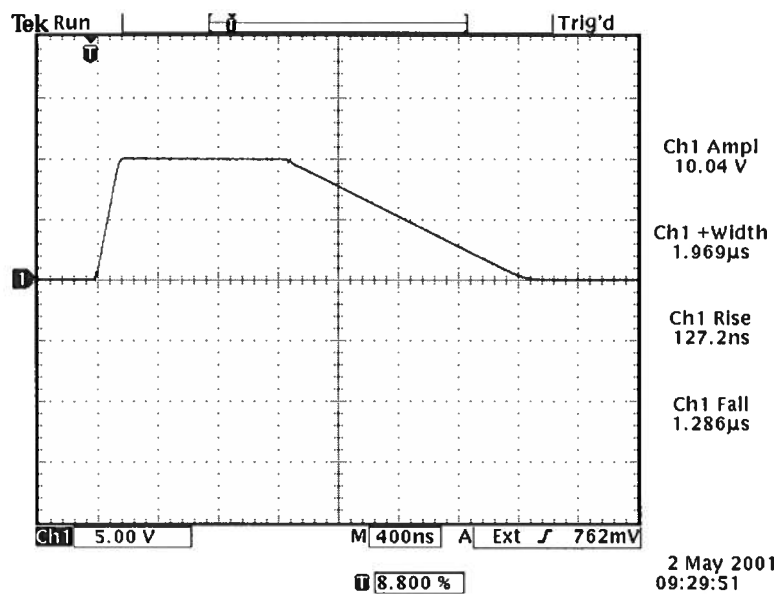

50 MHz OPERATION

50 MHz repetition rate, +10V into a 50 Ohm load, with rise and fall times set to minimum, and pulse width near minimum:

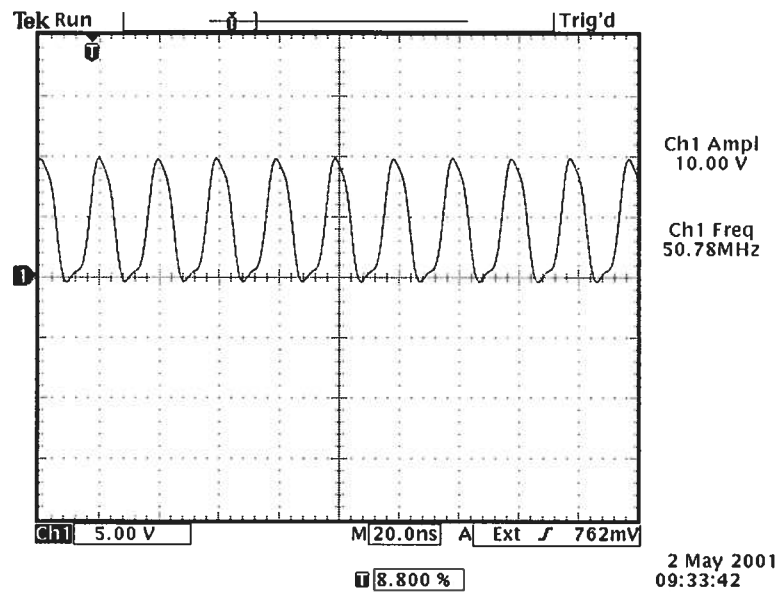

REPAIR INSTRUCTIONS

BLOWN AC FUSE

If the entire instrument appears to have failed, unplug the power cord from the rear panel. Slide the plastic cover on the rear-panel power entry model to expose the fuse. Pull the plastic lever to eject the fuse. Replace the fuse if required. (See the "REAR PANEL CONTROLS" section for details.)

BURN-OUT POWER SWITCH LIGHT

If the power switch does not light when the instrument is turned on, but the instrument is operative, the bulb in the power switch may be burnt out. To replace the bulb, unplug power cord from rear of the instrument and gently pry off the red plastic button from the black switch base. The bulb should then be visible. Gently grab the bulb with a pair of pliers, and pull it out. Install a replacement bulb, generic lamp type #382. Re-install the red plastic cap.

DAMAGED MAIN OUTPUT

The integrated circuit (IC) that generates the MAIN OUTPUT signal is installed in a socket, and may be replaced if it has been damaged through improper use. (The output stage does feature protection circuitry).

To replace this IC, turn off the instrument and remove the top cover. Locate the 24-pin IC labelled "U30" immediately behind the MAIN OUTPUT connector. This IC has a black clip-on heatsink. The IC can be removed by gently pulling it up and out of its socket.

Replacement ICs may be ordered directly from the manufacturer, Fairchild Semiconductor (www.fairchildsemi.com). The part number is KH103AI. The following part numbers are also acceptable substitutes: KH103AK, CLC103AI, and CLC103AM.

Apr 11/02

ed e