



AVTECH ELECTROSYSTEMS LTD.

NANOSECOND WAVEFORM ELECTRONICS
SINCE 1975

P.O. BOX 265
OGDENSBURG, NY
U.S.A. 13669-0265
TEL: (315) 472-5270
FAX: (613) 226-2802

TEL: 1-800-265-6681
FAX: 1-800-561-1970

e-mail: info@avtechpulse.com
<http://www.avtechpulse.com/>

BOX 5120, LCD MERIVALE
OTTAWA, ONTARIO
CANADA K2C 3H4
TEL: (613) 226-5772
FAX: (613) 226-2802

INSTRUCTIONS

MODEL AV-1010-C

0 TO ± 100 VOLTS, 2 AMP,

10 ns RISE & FALL TIME

LAB PULSE GENERATOR AND LASER DIODE DRIVER

SERIAL NUMBER: _____

WARRANTY

Avtech Electrosystems Ltd. warrants products of its manufacture to be free from defects in material and workmanship under conditions of normal use. If, within one year after delivery to the original owner, and after prepaid return by the original owner, this Avtech product is found to be defective, Avtech shall at its option repair or replace said defective item. This warranty does not apply to units which have been disassembled, modified or subjected to conditions exceeding the applicable specifications or ratings. This warranty is the extent of the obligation assumed by Avtech with respect to this product and no other warranty or guarantee is either expressed or implied.

TECHNICAL SUPPORT

Phone: 613-226-5772 or 1-800-265-6681

Fax: 613-226-2802 or 1-800-561-1970

E-mail: info@avtechpulse.com

World Wide Web: <http://www.avtechpulse.com>

TABLE OF CONTENTS

WARRANTY.....	2
TECHNICAL SUPPORT.....	2
TABLE OF CONTENTS.....	3
INTRODUCTION.....	5
SPECIFICATIONS.....	6
EUROPEAN REGULATORY NOTES.....	7
EC DECLARATION OF CONFORMITY.....	7
DIRECTIVE 2002/95/EC (RoHS).....	7
INSTALLATION.....	8
VISUAL CHECK.....	8
POWER RATINGS.....	8
CONNECTION TO THE POWER SUPPLY.....	8
PROTECTION FROM ELECTRIC SHOCK.....	9
ENVIRONMENTAL CONDITIONS.....	9
FUSES.....	11
AC FUSE REPLACEMENT.....	11
DC FUSE REPLACEMENT.....	12
FUSE RATINGS.....	12
FRONT PANEL CONTROLS.....	13
REAR PANEL CONTROLS.....	16
GENERAL INFORMATION.....	17
BASIC TEST ARRANGEMENT.....	17
BASIC PULSE CONTROL.....	17
MINIMIZING WAVEFORM DISTORTIONS.....	19
OUTPUT IMPEDANCE.....	19
GENERATING LOW-VOLTAGE WAVEFORMS.....	19
USE 50Ω TRANSMISSION LINES.....	19
USE LOW-INDUCTANCE LOADS.....	19
OPERATIONAL CHECK.....	21
OTHER INFORMATION.....	23
APPLICATION NOTES.....	23
MANUAL FEEDBACK.....	23

MECHANICAL INFORMATION.....	24
TOP COVER REMOVAL.....	24
RACK MOUNTING.....	24
ELECTROMAGNETIC INTERFERENCE.....	24
MAINTENANCE.....	25
REGULAR MAINTENANCE.....	25
CLEANING.....	25
PERFORMANCE CHECK SHEET.....	26

Manual Reference: T:\instructword\av-1010\av-1010-c, edition 3.sxw.
Last modified February 14, 2005.
Copyright © 2005 Avtech Electrosystems Ltd, All Rights Reserved.

INTRODUCTION

The AV-1010-C is a high performance instrument capable generating amplitudes up to ± 100 V into 50Ω at repetition rates up to 1 MHz. Pulse widths are variable up to 10 ms. Rise and fall times are fixed at less than 10 ns. The AV-1010-C provides single or double pulse output and can be triggered or gated by an external source. A front-panel pushbutton can also be used to trigger the instrument. The output pulse width can be set to follow an input trigger pulse width and the output amplitude can be controlled by an externally applied 0 to +10 Volts DC control voltage.

The output impedance depends on the amplitude range selected. For the ± 100 V ranges, the output impedance is approximately 2Ω . In the lower ranges (± 30 V and below), the output impedance is 50Ω .

The MOSFET output stages will safely withstand any combination of front panel control settings, output open or short circuits, and high duty cycles. An internal power supply monitor removes the power to the output stage for five seconds if an average power overload exists. After that time, the unit operates normally for one second, and if the overload condition persists, the power is cut again. This cycle repeats until the overload is removed. With a 50Ω load the unit will withstand duty cycles as high as 10%. The output stage will source up to 2.5 Amps (and will automatically shut down if the load current exceeds 2.5 Amps).

Application notes describing the use of the AV-1010 and AV-1011 families of pulse generators are available on the Avtech web site, <http://www.avtechpulse.com>. In particular, application notes describing techniques for driving laser diodes, and for using pulse transformers to boost the output current, are presented.

This instrument is intended for use in research and development laboratories.

SPECIFICATIONS

Model:	AV-1010-C
Output amplitude into 50 Ω :	Range 1: 0.3 to 1 V Range 2: 0.3 to 3 V Range 3: 0.3 to 10 V Range 4: 0.3 to 30 V Range 5: 0.3 to 100 V (10 turn fine control)
Output polarity:	+ or -, switch-selectable
Rise time, fall time (20%-80%):	≤ 10 ns
Pulse width (FWHM):	25 ns to 10 ms (6 position switch & fine control)
Pulse repetition rate:	10 Hz to 1 MHz (5 position switch & fine control)
Maximum duty cycle:	50 Ω load, maximum amplitude: 10 % 10 k Ω load, maximum amplitude: 80 %
Output impedance:	50 Ω in 1, 5, 10 & 30 V ranges 2 Ω in the 100 V range
Pulse aberrations:	$\leq \pm 5$ % of amplitude
Jitter:	Pulse width: $\leq .1\%$, typically $< .01\%$ Delay/Advance: $\leq .1\%$, + 0.5 ns Period: $\leq .1\%$, + 0.5 ns
Delayed/advanced range:	100 ns to 10 ms, relative to SYNC OUT
Sync output:	+3 Volts, 50 ns ($R_L > 1$ k Ω)
Gated operation:	Triggers when the gate input is open circuited (or $V_{APPLIED} \geq 2$ V)
External trigger:	Mode A: TTL (0 - 5V), > 50 ns width Mode B: TTL (0 - 5V), $PW_{IN} = PW_{OUT}$ Includes single-pulse pushbutton
Minimum propagation delay, external trigger modes:	Advance: 200 ns Delay: 300 ns Double pulse: 200 ns $PW_{IN} = PW_{OUT}$: 100 ns
Protected against:	open and short circuits, high duty cycle
Connectors:	BNC female
Power source:	100 - 240 Volts, 50 - 60 Hz
Dimensions (H x W x D):	100 mm x 430 mm x 375 mm (3.9" x 17" x 14.8")
Weight:	≤ 10 kg (22 lbs)
Chassis material:	Aluminum. Anodized aluminum front panel with cast aluminum side panels (with blue-gray plastic trim) and aluminum top and bottom panels with blue-gray plastic trim.
Operating temperature:	+ 5° C to + 40° C
Accessories furnished:	one detachable 6' power cord, one operation-maintenance manual
Option available:	19" rack mount kit (-R5)

EUROPEAN REGULATORY NOTES

EC DECLARATION OF CONFORMITY

We

Avtech Electrosystems Ltd.
P.O. Box 5120, LCD Merivale
Ottawa, Ontario
Canada K2C 3H4

declare that this pulse generator meets the intent of Directive 89/336/EEC for Electromagnetic Compatibility. Compliance pertains to the following specifications as listed in the official Journal of the European Communities:

EN 50081-1 Emission

EN 50082-1 Immunity

and that this pulse generator meets the intent of the Low Voltage Directive 72/23/EEC as amended by 93/68/EEC. Compliance pertains to the following specifications as listed in the official Journal of the European Communities:

EN 61010-1:2001 Safety requirements for electrical equipment for measurement, control, and laboratory use



DIRECTIVE 2002/95/EC (RoHS)

This instrument is exempt from Directive 2002/95/EC of the European Parliament and of the Council of 27 January 2003 on the Restriction of the use of certain Hazardous Substances (RoHS) in electrical and electronic equipment. Specifically, Avtech instruments are considered "Monitoring and control instruments" (Category 9) as defined in Annex 1A of Directive 2002/96/EC. The Directive 2002/95/EC only applies to Directive 2002/96/EC categories 1-7 and 10, as stated in the "Article 2 - Scope" section of Directive 2002/95/EC.

INSTALLATION

VISUAL CHECK

After unpacking the instrument mainframe and the transformer module, examine to ensure that they have not been damaged in shipment. Visually inspect all connectors, knobs, and handles. Confirm that a power cord and an instrumentation manual (this manual), are with the instrument. If the instrument has been damaged, file a claim immediately with the company that transported the instrument.

POWER RATINGS

This instrument is intended to operate from 100 - 240 V, 50 - 60 Hz.

The maximum power consumption is 90 Watts. Please see the "FUSES" section for information about the appropriate AC and DC fuses.

This instrument is an "Installation Category II" instrument, intended for operation from a normal single-phase supply.

CONNECTION TO THE POWER SUPPLY

An IEC-320 three-pronged recessed male socket is provided on the back panel for AC power connection to the instrument. One end of the detachable power cord that is supplied with the instrument plugs into this socket. The other end of the detachable power cord plugs into the local mains supply. Use only the cable supplied with the instrument. The mains supply must be earthed, and the cord used to connect the instrument to the mains supply must provide an earth connection. (The supplied cord does this.)

 **Warning:** Failure to use a grounded outlet may result in injury or death due to electric shock. This product uses a power cord with a ground connection. It must be connected to a properly grounded outlet. The instrument chassis is connected to the ground wire in the power cord.

The table below describes the power cord that is normally supplied with this instrument, depending on the destination region:

Destination Region	Description	Manufacturer	Part Number
Continental Europe	European CEE 7/7 "Schuko" 230V, 50Hz	Volex (http://www.volex.com)	17850-C3-326
United Kingdom	BS 1363, 230V, 50Hz	Volex (http://www.volex.com)	17962-C3-10
Switzerland	SEV 1011, 230V, 50Hz	Volex (http://www.volex.com)	2102H-C3-10
Israel	SI 32, 220V, 50Hz	Volex (http://www.volex.com)	2115H-C3-10
North America, and all other areas	NEMA 5-15, 120V, 60 Hz	Volex (http://www.volex.com)	17250-B1-10
		Qualtek (http://www.qualtekusa.com)	312007-01

PROTECTION FROM ELECTRIC SHOCK

 Operators of this instrument must be protected from electric shock at all times. The owner must ensure that operators are prevented access and/or are insulated from every connection point. In some cases, connections must be exposed to potential human contact. Operators must be trained to protect themselves from the risk of electric shock. This instrument is intended for use by qualified personnel who recognize shock hazards and are familiar with safety precautions required to avoid possibly injury. In particular, operators should:

- 1) Keep exposed high-voltage wiring to an absolute minimum.
- 2) Wherever possible, use shielded connectors and cabling.
- 3) Connect and disconnect loads and cables only when the instrument is turned off.
- 4) Keep in mind that all cables, connectors, oscilloscope probes, and loads must have an appropriate voltage rating.
- 5) Do not attempt any repairs on the instrument, beyond the fuse replacement procedures described in this manual. Contact Avtech technical support (see page 2 for contact information) if the instrument requires servicing. Service is to be performed solely by qualified service personnel.

ENVIRONMENTAL CONDITIONS

This instrument is intended for use under the following conditions:

- indoor use;
- altitude up to 2 000 m;
- temperature 5 °C to 40 °C;
- maximum relative humidity 80 % for temperatures up to 31 °C decreasing linearly to 50 % relative humidity at 40 °C;

- Mains supply voltage fluctuations up to ± 10 % of the nominal voltage;
- no pollution or only dry, non-conductive pollution.

FUSES

This instrument contains four fuses. All are accessible from the rear-panel. Two protect the AC prime power input, and two protect the internal DC power supplies. The locations of the fuses on the rear panel are shown in the figure below:

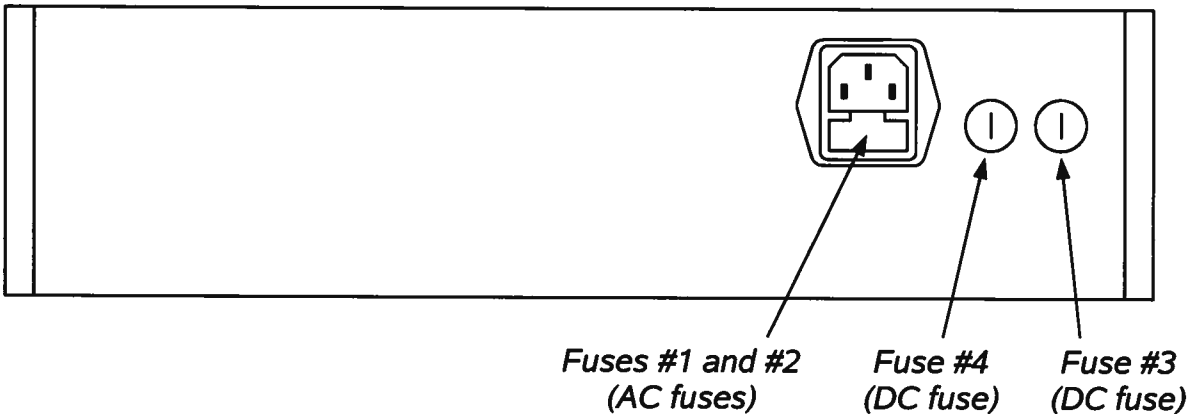

AC FUSE REPLACEMENT

To physically access the AC fuses, the power cord must be detached from the rear panel of the instrument. The fuse drawer may then be extracted using a small flat-head screwdriver, as shown below:

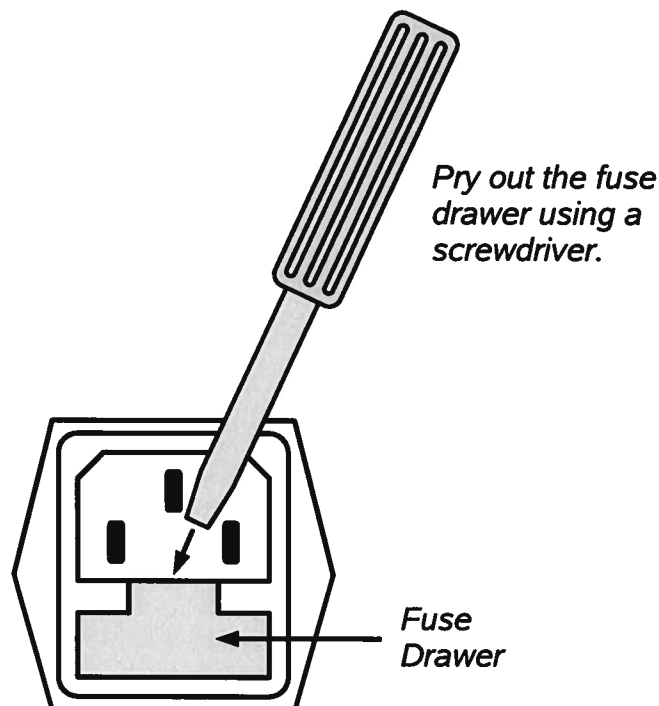

DC FUSE REPLACEMENT

The DC fuses may be replaced by inserting the tip of a flat-head screwdriver into the fuse holder slot, and rotating the slot counter-clockwise. The fuse and its carrier will then pop out.

FUSE RATINGS

The following table lists the required fuses:

Fuses	Nominal Mains Voltage	Rating	Case Size	Manufacturer's Part Number (Wickmann)	Distributor's Part Number (Digi-Key)
#1, #2 (AC)	115 V	0.8A, 250V, Time-Delay	5 x 20 mm	1950800000	WK5046-ND
	230 V	0.5A, 250V, Time-Delay	5 x 20 mm	1950500000	WK5041-ND
#3 (DC)	N/A	2.5A, 250V, Time-Delay	5 x 20 mm	1951250000	WK5058-ND
#4 (DC)	N/A	2.0A, 250V, Time-Delay	5 x 20 mm	1951200000	WK5057-ND

The fuse manufacturer is Wickmann (<http://www.wickmann.com/>).

Replacement fuses may be easily obtained from Digi-Key (<http://www.digikey.com/>) and other distributors.

FRONT PANEL CONTROLS

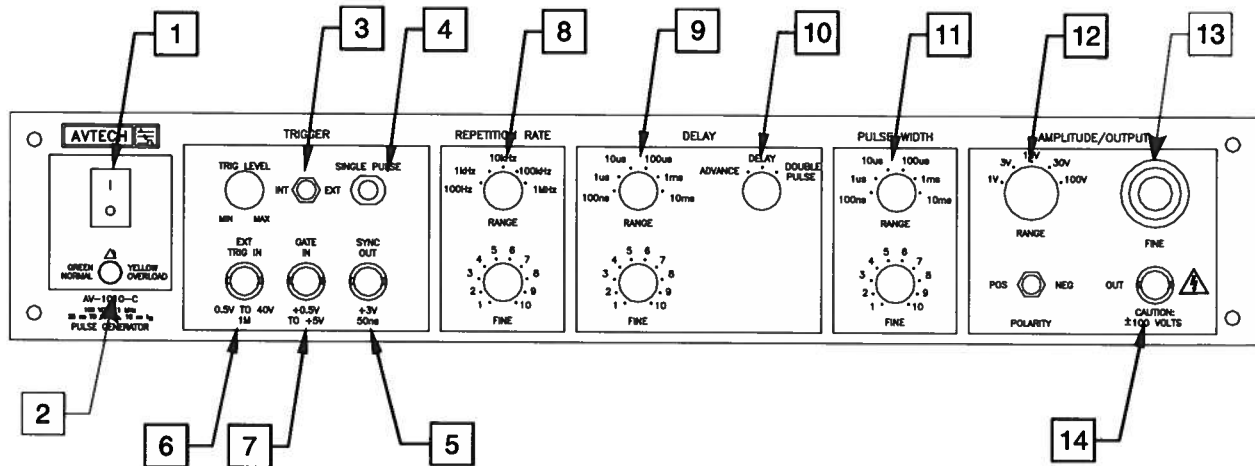

- 1) **POWER Switch**. This is the main power switch. When turning the instrument on, there may be a delay of several seconds before the instrument appears to respond.
- 2) **OVERLOAD Indicator**. When the instrument is powered, this indicator is normally green, indicating normal operation. If this indicator is yellow, an internal automatic overload protection circuit has been tripped. If the unit is overloaded (by operating at an exceedingly high duty cycle or by operating into a very low impedance), the protective circuit will disable the output of the instrument and turn the indicator light yellow. The light will stay yellow (i.e. output disabled) for about 5 seconds after which the instrument will attempt to re-enable the output (i.e. light green) for about 1 second. If the overload condition persists, the output will be disabled again (i.e. light yellow) for another 5 seconds. If the overload condition has been removed, the instrument will resume normal operation.

This overload indicator may flash yellow briefly at start-up. This is not a cause for concern.

Note that the output stage will safely withstand a short-circuited load condition.

Overload conditions may be removed by:

- a) Reducing PRF (i.e. switch to a lower range)
 - b) Reducing pulse width (i.e. switch to a lower range)
 - c) Removing output low load impedance (if any)
 - d) Reducing the output amplitude (i.e. switch to a lower range)
- 3) **INT/EXT Switch**. In the "INT" position the instrument is internally triggered and the "SYNC OUT" connector provides a SYNC output for triggering other instruments, such as oscilloscopes. In the "EXT" position the instrument is triggered by a $\pm 0.5V$ to $\pm 40V$, 50 ns (or wider) input pulse on the "EXT TRIG IN" connector, or by

pressing the "SINGLE PULSE" push button.

- 4) SINGLE PULSE Push Button. The "SINGLE PULSE" push button will trigger the instrument manually for one cycle of output, when the "INT/EXT" switch is in the "EXT" position. Otherwise, the push button has no effect.
- 5) SYNC OUT. When the "INT/EXT" switch is in the "INT" position, this connector supplies a SYNC output that can be used to trigger other equipment, particularly oscilloscopes. This signal leads, or lags, the main output by a duration set by the "DELAY" controls and has an approximate amplitude of +3 Volts to $R_L > 1 \text{ k}\Omega$ with a pulse width of about 50 ns.
- 6) TRIG IN. When the "INT/EXT" switch is in the "EXT" position, the external trigger (± 0.5 Volts to ± 40 Volts, $PW > 50$ ns) is applied to this connector. This input presents a high impedance ($1 \text{ M}\Omega$). The "TRIG LEVEL" dial controls the trigger level of the external input. The fully counter-clockwise position corresponds to -40V, and the fully clockwise position corresponds to +40V.
- 7) GATE Input. The GATE input will suppress the triggering of the instrument if taken to a TTL LOW level (i.e. 0 to 0.5V). If it is left open or taken to a TTL HIGH level (3V to 5V), normal triggering will occur ($R_{IN} = 1 \text{ k}\Omega$).
- 8) REPETITION RATE Controls. The rotary switch marked "RANGE" selects the pulse repetition rate for the internally triggered mode. The vernier (labelled "FINE") provides continuously variable control of each range. There are five ranges and the instrument is set to the rate indicated on the front panel when the vernier is in the clockwise position.

10 Hz	- 100 Hz
100 Hz	- 1 kHz
1 kHz	- 10 kHz
10 kHz	- 100 kHz
100 kHz	- 1.0 MHz
- 9) DELAY Controls. The rotary switch selects one of six ranges and the vernier provides continuously variable control of each range. The instrument is set to the delay indicated on the front panel when the vernier is in the clockwise position.

minimum	- 100 ns
100 ns	- 1 us
1 us	- 10 us
10 us	- 100 us
100 us	- 1 ms
1 ms	- 10 ms
- 10) ADVANCE, DELAY, DOUBLE PULSE. With this three-position switch in the ADVANCE position, the leading edge of the output pulse precedes the leading edge of the SYNC output. When in the DELAY position, the leading edge of the SYNC output precedes the leading edge of the main output. When in the DOUBLE PULSE

position, the main output provides two successive output pulses having a separation determined by the DELAY (8) controls.

- 11) PULSE WIDTH Controls. The rotary switch selects one of six ranges and the vernier provides continuously variable control of each range. The instrument is set to the pulse width indicated on the front panel when the vernier is in the clockwise position.

minimum	- 100 ns
100 ns	- 1 us
1 us	- 10 us
10 us	- 100 us
100 us	- 1 ms
1 ms	- 10 ms

Note: When switching to wider pulse width ranges at high output amplitudes, the output amplitude may drop as the duty cycle is suddenly increased. To return the amplitude to its proper value, reduce the duty cycle briefly (by rotating the pulse width vernier control counterclockwise, or reducing the repetition rate). The internal power supply will recover, and the controls can be returned to their original settings.

- 12) AMPLITUDE RANGE Switch. This five-position switch controls the amplitude full-scale range (and output impedance). The full-scale range may be set to 1V, 3V, 10V, 30V, or 100V. The two-position switch immediately below the amplitude range switch controls the output polarity (positive or negative)/

In the 100V range, the output impedance is 2Ω . In the other ranges, the output impedance (Z_{OUT}) is 50Ω .

The full-scale range values assume that a 50Ω load is being used. If a high impedance load is used (i.e. $R_L \gg 50\Omega$), then the actual full-scale range will be twice the indicated value in ranges with a Z_{OUT} of 50Ω .

The best waveform will be obtained if the lowest-possible range is used, and if a 50Ω load is used.

- 13) AMPLITUDE FINE. The ten-turn amplitude vernier provides continuously variable control of the peak amplitude of the main output from 0 to the full-scale range value, as set by the range switch.

- 14) OUT. This BNC connector provides the main output signal, into load impedances of 50Ω or greater. (The best waveforms will be obtained for 50Ω loads, however.)



Caution: Voltages as high as $\pm 100V$ may be present on the center conductor of this output connector. Avoid touching this conductor. Connect to this connector using standard coaxial cable, to ensure that the center conductor is not exposed.

REAR PANEL CONTROLS

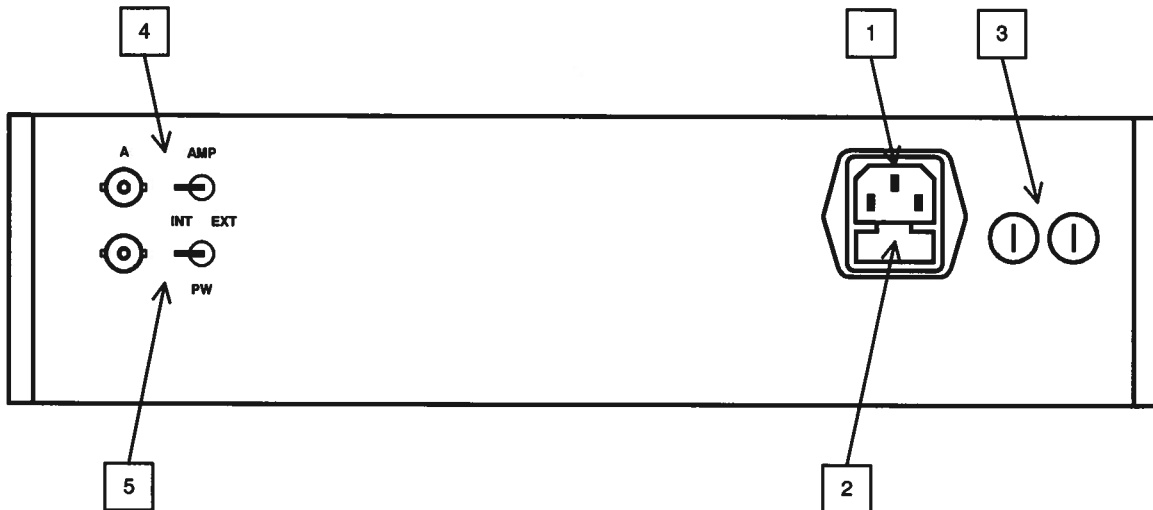

1. **AC POWER INPUT.** An IEC-320 C14 three-pronged recessed male socket is provided on the back panel for AC power connection to the instrument. One end of the detachable power cord that is supplied with the instrument plugs into this socket.
2. **AC FUSE DRAWER.** The two fuses that protect the AC input are located in this drawer. Please see the “FUSES” section of this manual for more information.
3. **DC FUSES.** These two fuses protect the internal DC power supplies. Please see the “FUSES” sections of this manual for more information.
4. **EA SWITCH AND INPUT.** When this switch is set to the “INT” position, the output amplitude is controlled by the front-panel amplitude dial. When this switch is set to the “EXT” position, the output amplitude is controlled by the voltage applied to the “A” BNC connector. 0V in corresponds to zero amplitude, and +10V DC in corresponds to maximum amplitude (+100V). The input impedance of the “A” connector is > 10 kΩ.
5. **PW INPUT.** The pulse generator may be triggered externally in a $PW_{OUT} = PW_{IN}$ mode by setting the switch in the EXT position and applying a TTL level pulse with the desired pulse width to the A connector. The front-panel timing controls are disabled in this mode.

GENERAL INFORMATION

BASIC TEST ARRANGEMENT

The AV-1010-C should normally be connected as shown below:

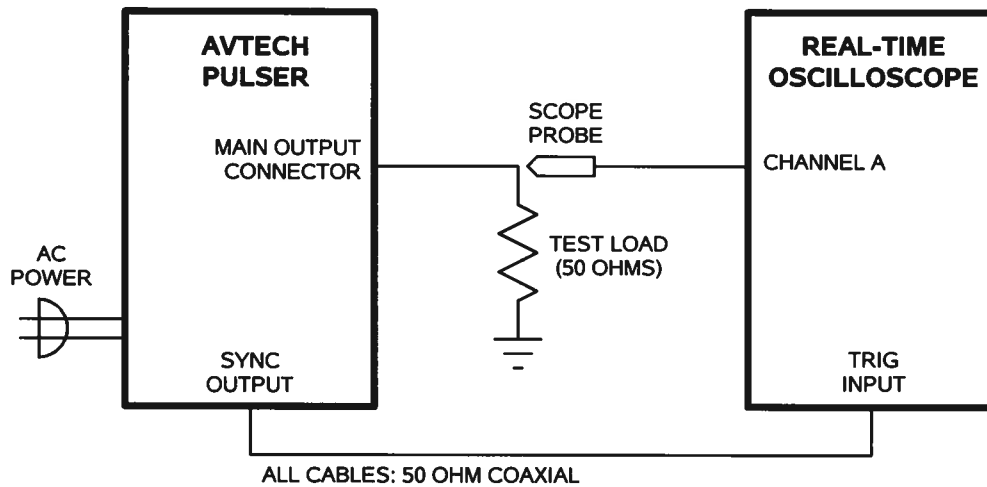

BASIC PULSE CONTROL

This instrument can be triggered by its own internal clock or by an external TTL trigger signal. When triggered internally, two mainframe output channels respond to the trigger: OUT and SYNC.

- OUT. This is the main output. The maximum output voltage is 100V.
- SYNC. The SYNC pulse is a fixed-width TTL-level reference pulse used to trigger oscilloscopes or other measurement systems.

When the ADVANCE/DELAY switch is set to "ADVANCE", the SYNC output precedes the main output. These pulses are illustrated below:

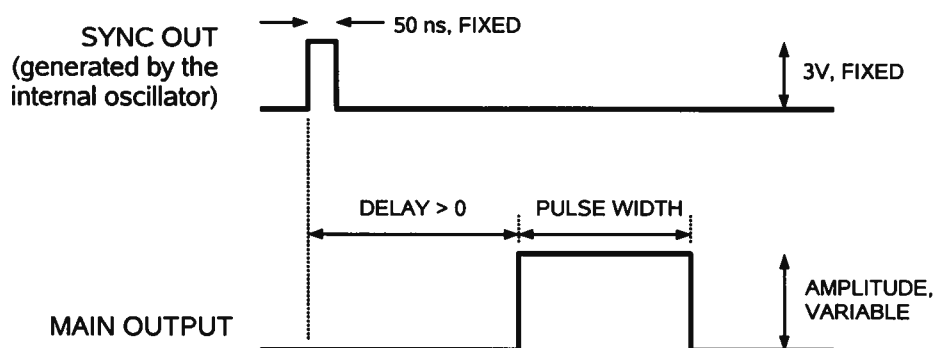

When the ADVANCE/DELAY switch is set to "DELAY", the TRIG output occurs after the main output. This illustrated below:

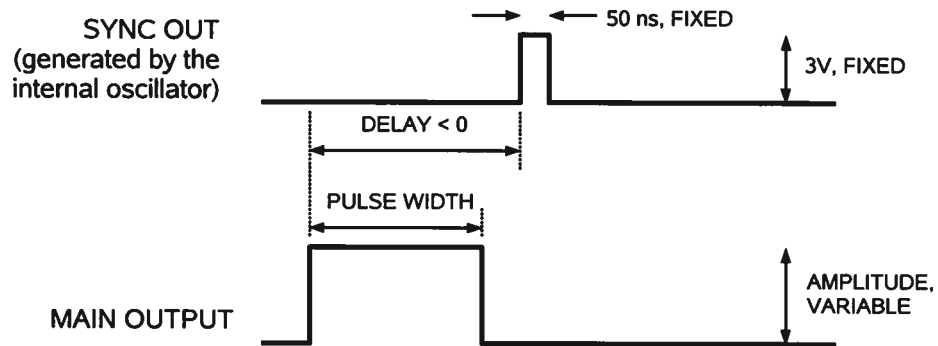

When triggered externally, the EXT TRIG connector acts as an input:

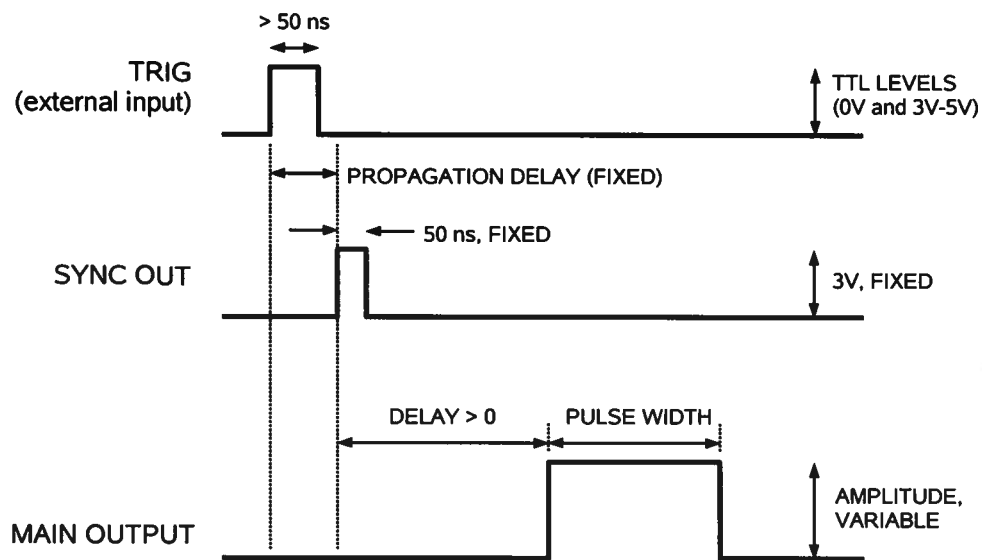

An external trigger may alternatively be applied to the rear-panel "PW" input. If the adjacent switch is set to "EXT", the instrument will be triggered by this input, and the output pulse width will be approximately equal to the input pulse width. The front-panel timing controls are disabled in this mode.

MINIMIZING WAVEFORM DISTORTIONS

OUTPUT IMPEDANCE

The output impedance of the AV-1010-C can be set at 2Ω or 50Ω using the amplitude range switch. The output impedance is 2Ω in the $\pm 100\text{V}$ ranges, and 50Ω in the lower ranges.

When driving a high impedance load (i.e., $R_L \gg 50\Omega$), the amplitude range should be set so that the output impedance is 50Ω . This will minimize waveform ringing and transmission line reflections, without adversely affecting the pulse amplitude. In this configuration, the output voltage will be twice the voltage that would be observed into a 50Ω load (i.e., the $+25\text{V}$ range will actually provide up to $+50\text{V}$).

When driving a 50Ω load, it is also highly desirable to set the output impedance to 50Ω . However, the output impedance and the load resistance will cause a resistive voltage-divider effect, reducing the output amplitude at the load by a factor of two. Thus, the 50Ω output impedance ranges can only be used to generate amplitudes of up to $\pm 25\text{V}$.

The load impedance must always be equal to or greater than 50 Ohms, even if the output impedance is 50 Ohms.

See Application Note 1A, at <http://www.avtechpulse.com/appnote/av1010/>, for more information.

GENERATING LOW-VOLTAGE WAVEFORMS

When generating low-voltage waveforms, the output waveforms will have much less distortion (i.e. ringing) if the output impedance is set to 50Ω .

USE 50Ω TRANSMISSION LINES

Connect the load to the pulse generator with 50Ω transmission lines (e.g. RG-58 or RG-174 cable). If possible, use a 50Ω load. If the actual device under test has a high impedance, consider adding a 50Ω termination in parallel with the load to properly terminate the transmission line.

Setting the pulse generator output impedance to 50Ω will “back-match” the transmission line, resulting in improved performance.

USE LOW-INDUCTANCE LOADS

Lenz’s Law predicts that for an inductive voltage spike will be generated when the current through an inductance changes. Specifically, $V_{\text{SPIKE}} = L \times dI_{\text{LOAD}}/dt$, where L is

the inductance, I_{LOAD} is the load current change, and t is time. For this reason, it is important to keep any parasitic in the load low. This means keeping wiring short, and using low inductance components. In particular, wire-wound resistors should be avoided.

OPERATIONAL CHECK

This check is to confirm that the instrument is fully functional. Set the controls to the following values:

FRONT PANEL

- INT/EXT Switch: INT position
- REPETITION RATE RANGE Switch: 10 kHz
- REPETITION RATE Vernier: Maximum (fully clockwise)
- DELAY RANGE Switch: 1 us
- DELAY Vernier: MID range
- ADVANCE, DELAY, DOUBLE PULSE: DELAY
- PULSE WIDTH RANGE Switch: 1 us
- PULSE WIDTH Vernier: Maximum (fully clockwise)
- AMPLITUDE RANGE Switch: 30V
- POLARITY Switch: +
- AMPLITUDE Vernier: 5.0 (half-maximum)

REAR PANEL

- AMP: INT
- PW: INT

Connect a cable from the SYNC OUT connector to the TRIG input of an oscilloscope. Connect a 2W (or higher) 50 Ohm load to the OUT connector and place the scope probe across this load.

Set the oscilloscope to trigger externally with the vertical setting at 5 Volts/div and the horizontal setting at 1 us/div. Then follow the instructions below and compare what is seen on the oscilloscope to what is described. Only approximate values are needed to confirm operation.

STEP	CONTROL	OPERATION	RESULTS
1	Power	Push in (ON)	+15V pulses at the main output, with period 100 us, pulse width 1.0 us, <10ns rise & fall times.
2	Repetition Rate Vernier	Rotate to Minimum (fully counter-clockwise), then to Maximum (fully clockwise)	Period rises to about 1 ms then falls to about 100 us.
3	Delay Vernier	Rotate to Maximum (fully clockwise), then to Minimum (fully counter-clockwise)	Pulses shift to the right on the oscilloscope by 1 us, then back.
4	Pulse Width Vernier	Rotate to Minimum (fully counter-clockwise), then to Maximum (fully clockwise)	Pulse width varies from 100 ns to 1.0 us.
5	Polarity Switch	Switch to -, then to +	Pulse polarity becomes negative & then positive.
6	Amplitude Range Switch	Switch to 100V	The output pulse amplitude will jump to +50V.

OTHER INFORMATION

APPLICATION NOTES

Application notes are available on the Avtech web site, at <http://www.avtechpulse.com/appnote>.

MANUAL FEEDBACK

Please report any errors or omissions in this manual, or suggestions for improvement, to info@avtechpulse.com. Thanks!

MECHANICAL INFORMATION

TOP COVER REMOVAL

If necessary, the interior of the instrument may be accessed by removing the four Phillips screws on the top panel. With the four screws removed, the top cover may be slid back (and off).

 Always disconnect the power cord and allow the instrument to sit unpowered for 10 minutes before opening the instrument. This will allow any internal stored charge to discharge.

There are no user-adjustable internal circuits. For repairs other than fuse replacement, please contact Avtech (info@avtechpulse.com) to arrange for the instrument to be returned to the factory for repair. Service is to be performed solely by qualified service personnel.

 Caution: High voltages are present inside the instrument during normal operation. Do not operate the instrument with the cover removed.

RACK MOUNTING

A rack mounting kit is available. The -R5 rack mount kit may be installed after first removing the one Phillips screw on the side panel adjacent to the front handle.

ELECTROMAGNETIC INTERFERENCE

To prevent electromagnetic interference with other equipment, all used outputs should be connected to shielded loads using shielded coaxial cables. Unused outputs should be terminated with shielded coaxial terminators or with shielded coaxial dust caps, to prevent unintentional electromagnetic radiation. All cords and cables should be less than 3m in length.

MAINTENANCE

REGULAR MAINTENANCE

This instrument does not require any regular maintenance.

On occasion, one or more of the four rear-panel fuses may require replacement. All fuses can be accessed from the rear panel. See the "FUSES" section for details.

CLEANING

If desired, the interior of the instrument may be cleaned using compressed air to dislodge any accumulated dust. (See the "TOP COVER REMOVAL" section for instructions on accessing the interior.) No other cleaning is recommended.

Feb 14/05