



AVTECH ELECTROSYSTEMS LTD.

NANOSECOND WAVEFORM ELECTRONICS
SINCE 1975

□ P.O. BOX 265
OGDENSBURG, NY
U.S.A. 13669-0265
TEL: (315) 472-5270
FAX: (613) 226-2802

TEL: 1-800-265-6681
FAX: 1-800-561-1970

e-mail: info@avtechpulse.com
<http://www.avtechpulse.com>

□ P.O. BOX 5120 STN. F
OTTAWA, ONTARIO
CANADA K2C 3H4
TEL: (613) 226-5772
FAX: (613) 226-2802

INSTRUCTIONS

MODEL AV-135B-PS AMPLIFIER

S.N.:

WARRANTY

Avtech Electrosystems Ltd. warrants products of its manufacture to be free from defects in material and workmanship under conditions of normal use. If, within one year after delivery to the original owner, and after prepaid return by the original owner, this Avtech product is found to be defective, Avtech shall at its option repair or replace said defective item. This warranty does not apply to units which have been disassembled, modified or subjected to conditions exceeding the applicable specifications or ratings. This warranty is the extent of the obligation assumed by Avtech with respect to this product and no other warranty or guarantee is either expressed or implied.

TECHNICAL SUPPORT

Phone: 613-226-5772 or 1-800-265-6681

Fax: 613-226-2802 or 1-800-561-1970

E-mail: info@avtechpulse.com

World Wide Web: <http://www.avtechpulse.com>

TABLE OF CONTENTS

| | |
|--|---|
| WARRANTY | 2 |
| TABLE OF CONTENTS | 3 |
| GENERAL INSTRUCTIONS | 4 |
| FIG. 1: AMPLIFIER TEST ARRANGEMENT | 5 |
| POWER SUPPLY AND FUSE REPLACEMENT | 6 |

Manual Reference: Q:\office\instructword\AV-135\AV-135B-PSeda-fig.doc, created February 22, 2000

GENERAL INSTRUCTIONS

Model AV-135B

The Model AV-135B amplifier is designed to amplify nanosecond rise time baseband pulses in the pulse width range of about 500 ps to 500 ns and CW signals in the frequency range of 1.0 MHz to 2.5 GHz. The basic specifications for the unit are as follows:

| | |
|----------------------|-----------------|
| Gain: | > 34 dB |
| Peak output voltage: | ± 1.0 Volt |
| Rise time: | ≤ 300 ps |
| Impedance level: | 50 Ohms nominal |
| Input VSWR: | $\leq 2.5:1$ |
| Output VSWR: | $\leq 2.5:1$ |
| Max. noise figure: | 2.8 dB |
| Rise time: | ≤ 300 ps |

CAUTION: The input to this amplifier does not include any overload protection and so it may be damaged if subjected to high amplitude spurious outputs such as those provided by some PMT. The warranty does not apply to such failures.

FIG. 1: AMPLIFIER TEST ARRANGEMENT

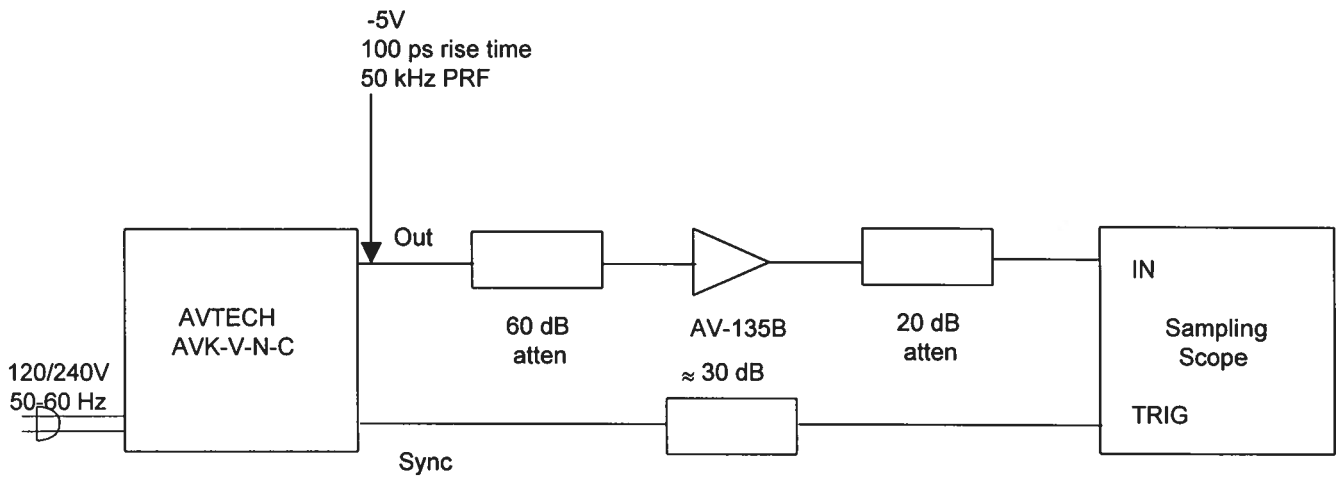

POWER SUPPLY AND FUSE REPLACEMENT

This instrument has three main fuses, plus two spares. One, which protects the AC input, is located in the rear-panel power entry module, as described in the "Rear Panel Controls" section of this manual. If the power appears to have failed, check the AC fuse first.

The other two fuses (plus two spares) are located on the internal DC power supply, as shown below:

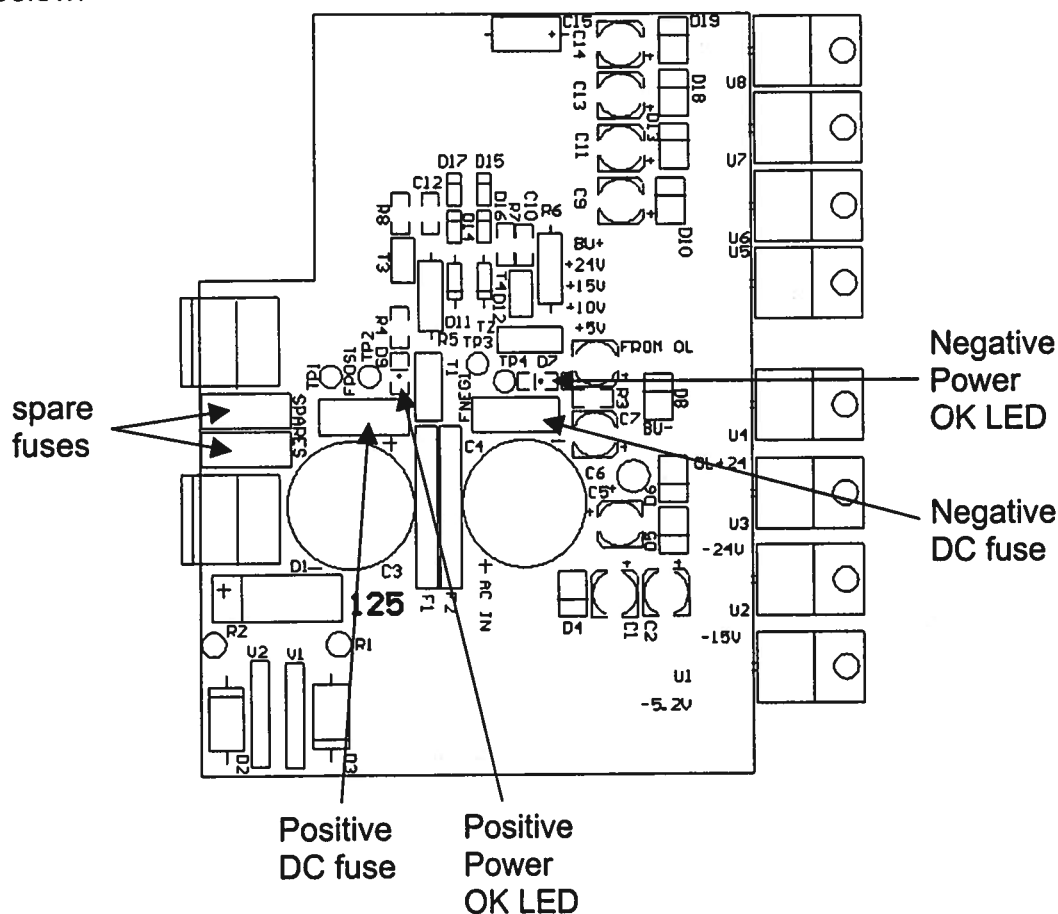

The four fuses on this circuit board are 0.5A slow-blow fuses, Littlefuse part number R452.500. (This fuse can be ordered from Digikey, www.digikey.com. The Digikey part number is F1341CT-ND).

If you suspect that the DC fuses are blown, follow this procedure:

1. Remove the top cover, by removing the four Phillips screws on the top cover and then sliding the cover back and off.
2. Locate the two "Power OK" LEDs on the power supply circuit board, as illustrated above.
3. Turn on the instrument.

4. Observe the "Power OK" LEDs. If the fuses are not blown, the two LEDs will be lit (bright red). If one of the LEDs is not lit, the fuse next to it has blown.
5. Turn off the instrument.
6. If a fuse is blown, use needle-nose pliers to remove the blown fuse from its surface-mount holder.
7. Replace the fuse. (Two spare 0.5 Amp fuses are provided on the circuit board. They may be transferred to the active fuse locations using needle-nose pliers.)

moved fwd
12/05/2001