



AVTECH ELECTROSYSTEMS LTD.

NANOSECOND WAVEFORM ELECTRONICS
SINCE 1975

P.O. BOX 265
OGDENSBURG, NY
U.S.A. 13669-0265

TEL: 888-670-8729 (USA & Canada) or +1-613-226-5772 (Intl)
FAX: 800-561-1970 (USA & Canada) or +1-613-226-2802 (Intl)

info@avtechpulse.com - <http://www.avtechpulse.com/>

BOX 5120, LCD MERIVALE
OTTAWA, ONTARIO
CANADA K2C 3H4

INSTRUCTIONS

**MODEL AV-141C1-PS
×10 GAIN, ±3V OUTPUT
PULSE AMPLIFIER
WITH 800 ps RISE AND FALL TIMES**

SERIAL NUMBER: _____

WARRANTY

Avtech Electrosystems Ltd. warrants products of its manufacture to be free from defects in material and workmanship under conditions of normal use. If, within one year after delivery to the original owner, and after prepaid return by the original owner, this Avtech product is found to be defective, Avtech shall at its option repair or replace said defective item. This warranty does not apply to units which have been disassembled, modified or subjected to conditions exceeding the applicable specifications or ratings. This warranty is the extent of the obligation assumed by Avtech with respect to this product and no other warranty or guarantee is either expressed or implied.

TECHNICAL SUPPORT

Phone: 888-670-8729 (USA & Canada) or +1-613-226-5772 (Intl)

Fax: 800-561-1970 (USA & Canada) or +1-613-226-2802 (Intl)

E-mail: info@avtechpulse.com

World Wide Web: <http://www.avtechpulse.com>

TABLE OF CONTENTS

WARRANTY.....	2
TECHNICAL SUPPORT.....	2
TABLE OF CONTENTS.....	3
INTRODUCTION.....	4
SPECIFICATIONS.....	4
EUROPEAN REGULATORY NOTES.....	5
EC DECLARATION OF CONFORMITY.....	5
DIRECTIVE 2002/95/EC (RoHS).....	5
DIRECTIVE 2002/96/EC (WEEE).....	5
INSTALLATION.....	7
VISUAL CHECK.....	7
POWER RATINGS.....	7
CONNECTION TO THE POWER SUPPLY.....	7
PROTECTION FROM ELECTRIC SHOCK.....	8
ENVIRONMENTAL CONDITIONS.....	8
FUSES.....	10
AC FUSE REPLACEMENT.....	10
DC FUSE REPLACEMENT.....	11
FUSE RATINGS.....	11
FRONT PANEL CONTROLS.....	12
REAR PANEL CONTROLS.....	13
BASIC TEST ARRANGEMENT.....	14
PROTECTING YOUR INSTRUMENT.....	15
WIRING DIAGRAMS.....	16
WIRING OF AC POWER.....	16
PCB 158K - LOW VOLTAGE POWER SUPPLY, 1/3.....	17
PCB 158K - LOW VOLTAGE POWER SUPPLY, 2/3.....	18
PCB 158K - LOW VOLTAGE POWER SUPPLY, 3/3.....	19
MAIN WIRING.....	20
PERFORMANCE CHECK SHEET.....	21

INTRODUCTION

The Model AV-141C1-PS is high-performance bench-top amplifier instrument, designed to amplify bipolar nanosecond rise time baseband pulses in the pulse width range of 1.5 ns and higher and CW signals in the frequency range of DC to 800 MHz.

SPECIFICATIONS

Model:	AV-141C1-PS
Bandwidth:	DC - 800 MHz
Gain: in dB:	20 dB
voltage gain (V/V):	× 10
Rise/fall time ¹ :	800 ps
Input impedance:	50 Ω
Peak output: (to 50 Ω)	±3 V
Output impedance:	3 Ω, approx.
Min. input pulse width:	1.5 ns
Max. input pulse width:	No limit.
Equivalent input noise:	4 nV / √Hz
Connectors:	SMA
Prime power:	100 - 240 Volts, 50 - 60 Hz
Dimensions:	100 mm x 215 mm x 375 mm (3.9" x 8.5" x 14.8")

1) Measured for a pulse from 0V to maximum positive voltage output, between the 20% and 80% amplitude points.

EUROPEAN REGULATORY NOTES

EC DECLARATION OF CONFORMITY

We Avtech Electrosystems Ltd.
 P.O. Box 5120, LCD Merivale
 Ottawa, Ontario
 Canada K2C 3H4

declare that this pulse generator meets the intent of Directive 89/336/EEC for Electromagnetic Compatibility. Compliance pertains to the following specifications as listed in the official Journal of the European Communities:

EN 50081-1 Emission

EN 50082-1 Immunity

and that this pulse generator meets the intent of the Low Voltage Directive 72/23/EEC as amended by 93/68/EEC. Compliance pertains to the following specifications as listed in the official Journal of the European Communities:

EN 61010-1:2001 Safety requirements for electrical equipment for measurement, control, and laboratory use



DIRECTIVE 2002/95/EC (RoHS)

This instrument is exempt from Directive 2002/95/EC of the European Parliament and of the Council of 27 January 2003 on the Restriction of the use of certain Hazardous Substances (RoHS) in electrical and electronic equipment. Specifically, Avtech instruments are considered "Monitoring and control instruments" (Category 9) as defined in Annex 1A of Directive 2002/96/EC. The Directive 2002/95/EC only applies to Directive 2002/96/EC categories 1-7 and 10, as stated in the "Article 2 - Scope" section of Directive 2002/95/EC.

DIRECTIVE 2002/96/EC (WEEE)

European customers who have purchased this equipment directly from Avtech will have completed a "WEEE Responsibility Agreement" form, accepting responsibility for

WEEE compliance (as mandated in Directive 2002/96/EC of the European Union and local laws) on behalf of the customer, as provided for under Article 9 of Directive 2002/96/EC.

Customers who have purchased Avtech equipment through local representatives should consult with the representative to determine who has responsibility for WEEE compliance. Normally, such responsibilities will lie with the representative, unless other arrangements (under Article 9) have been made.

Requirements for WEEE compliance may include registration of products with local governments, reporting of recycling activities to local governments, and financing of recycling activities.



INSTALLATION

VISUAL CHECK

After unpacking the instrument mainframe and the transformer module, examine to ensure that they have not been damaged in shipment. Visually inspect all connectors, knobs, and handles. Confirm that a power cord and an instrumentation manual (this manual), are with the instrument. If the instrument has been damaged, file a claim immediately with the company that transported the instrument.

POWER RATINGS

This instrument is intended to operate from 100 - 240 V, 50 - 60 Hz.

The maximum power consumption is 57 Watts. Please see the "FUSES" section for information about the appropriate AC and DC fuses.

This instrument is an "Installation Category II" instrument, intended for operation from a normal single-phase supply.

CONNECTION TO THE POWER SUPPLY

An IEC-320 three-pronged recessed male socket is provided on the back panel for AC power connection to the instrument. One end of the detachable power cord that is supplied with the instrument plugs into this socket. The other end of the detachable power cord plugs into the local mains supply. Use only the cable supplied with the instrument. The mains supply must be earthed, and the cord used to connect the instrument to the mains supply must provide an earth connection. (The supplied cord does this.)

 **Warning:** Failure to use a grounded outlet may result in injury or death due to electric shock. This product uses a power cord with a ground connection. It must be connected to a properly grounded outlet. The instrument chassis is connected to the ground wire in the power cord.

The table below describes the power cord that is normally supplied with this instrument, depending on the destination region:

Destination Region	Description	Manufacturer	Part Number
Continental Europe	European CEE 7/7 "Schuko" 230V, 50Hz	Qualtek (http://www.qualtekusa.com)	319004-T01
United Kingdom	BS 1363, 230V, 50Hz	Qualtek (http://www.qualtekusa.com)	370001-E01
Switzerland	SEV 1011, 2 30V, 50Hz	Volex (http://www.volex.com)	2102H-C3-10
Israel	SI 32, 220V, 50Hz	Volex (http://www.volex.com)	2115H-C3-10
North America, and all other areas	NEMA 5-15, 120V, 60 Hz	Qualtek (http://www.qualtekusa.com)	312007-01

PROTECTION FROM ELECTRIC SHOCK

 Operators of this instrument must be protected from electric shock at all times. The owner must ensure that operators are prevented access and/or are insulated from every connection point. In some cases, connections must be exposed to potential human contact. Operators must be trained to protect themselves from the risk of electric shock. This instrument is intended for use by qualified personnel who recognize shock hazards and are familiar with safety precautions required to avoid possibly injury. In particular, operators should:

1. Keep exposed high-voltage wiring to an absolute minimum.
2. Wherever possible, use shielded connectors and cabling.
3. Connect and disconnect loads and cables only when the instrument is turned off.
4. Keep in mind that all cables, connectors, oscilloscope probes, and loads must have an appropriate voltage rating.
5. Do not attempt any repairs on the instrument, beyond the fuse replacement procedures described in this manual. Contact Avtech technical support (see page 2 for contact information) if the instrument requires servicing. Service is to be performed solely by qualified service personnel.

ENVIRONMENTAL CONDITIONS

This instrument is intended for use under the following conditions:

1. indoor use;
2. altitude up to 2 000 m;
3. temperature 5 °C to 40 °C;

4. maximum relative humidity 80 % for temperatures up to 31 °C decreasing linearly to 50 % relative humidity at 40 °C;
5. Mains supply voltage fluctuations up to ± 10 % of the nominal voltage;
6. no pollution or only dry, non-conductive pollution.

FUSES

This instrument contains four fuses. All are accessible from the rear-panel. Two protect the AC prime power input, and two protect the internal DC power supplies. The locations of the fuses on the rear panel are shown in the figure below:

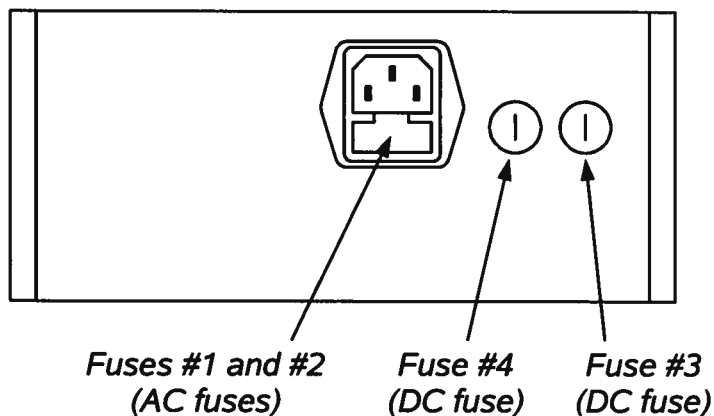

AC FUSE REPLACEMENT

To physically access the AC fuses, the power cord must be detached from the rear panel of the instrument. The fuse drawer may then be extracted using a small flat-head screwdriver, as shown below:

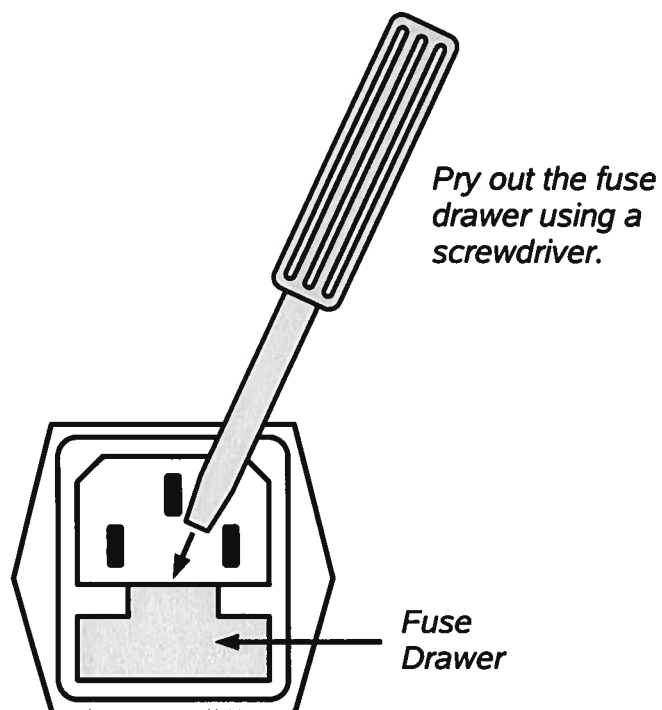

DC FUSE REPLACEMENT

The DC fuses may be replaced by inserting the tip of a flat-head screwdriver into the fuse holder slot, and rotating the slot counter-clockwise. The fuse and its carrier will then pop out.

FUSE RATINGS

The following table lists the required fuses:

Fuses	Nominal Mains Voltage	Rating	Case Size	Recommended Replacement Part	
				Littelfuse Part Number	Digi-Key Stock Number
#1, #2 (AC)	100-240V	0.5A, 250V, Time-Delay	5×20 mm	0218.500HXP	F2416-ND
#3 (DC)	N/A	0.25A, 250V, Time-Delay	5×20 mm	0218.250HXP	F2413-ND
#4 (DC)	N/A	Not used. A spare 0.25A fuse is installed here.			

The recommended fuse manufacturer is Littelfuse (<http://www.littelfuse.com>).

Replacement fuses may be easily obtained from Digi-Key (<http://www.digikey.com>) and other distributors.

FRONT PANEL CONTROLS

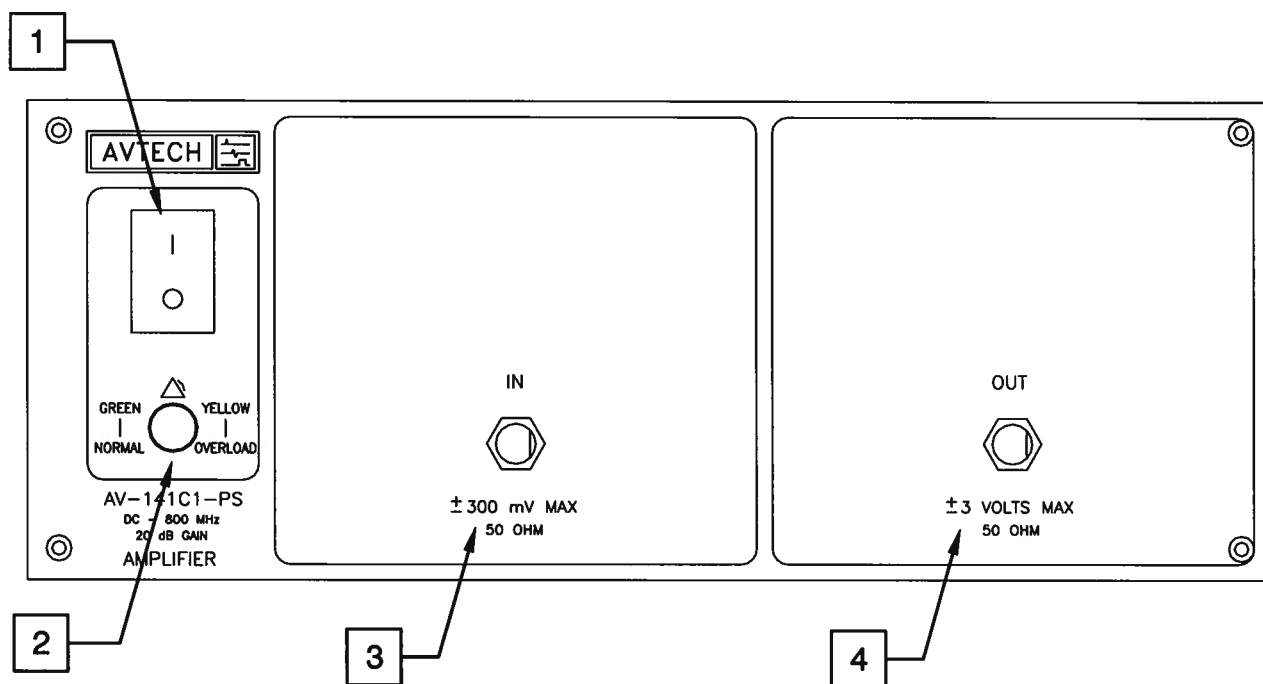

1. **POWER Switch.** This is the main power switch. When turning the instrument on, there may be a delay of several seconds before the instrument appears to respond.
2. **OVERLOAD Indicator.** When the instrument is powered, this indicator is normally green, indicating normal operation. If this indicator is yellow, an internal automatic overload protection circuit has been tripped. If the unit is overloaded (by operating at an exceedingly high duty cycle or by operating into a very low impedance), the protective circuit will disable the output of the instrument and turn the indicator light yellow. The light will stay yellow (i.e. output disabled) for about 5 seconds after which the instrument will attempt to re-enable the output (i.e. light green) for about 1 second. If the overload condition persists, the output will be disabled again (i.e. light yellow) for another 5 seconds. If the overload condition has been removed, the instrument will resume normal operation.

This overload indicator may flash yellow briefly at start-up. This is not a cause for concern.

3. **IN CONNECTOR.** The input is applied to this SMA connector. The input voltage must always lie between -300 mV and +300 mV. Voltages outside of this range may damage the instrument. The input impedance is 50Ω.
4. **OUT Connector.** This is the output. It can drive loads impedances of 50 Ohms or higher.

REAR PANEL CONTROLS

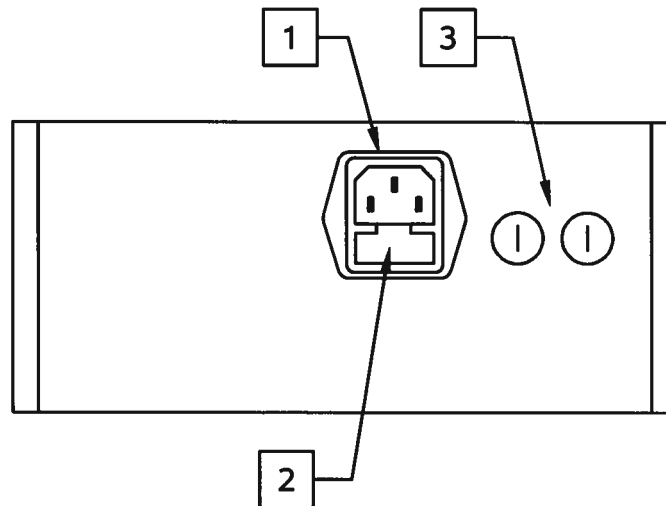

1. AC POWER INPUT. An IEC-320 C14 three-pronged recessed male socket is provided on the back panel for AC power connection to the instrument. One end of the detachable power cord that is supplied with the instrument plugs into this socket.
2. AC FUSE DRAWER. The two fuses that protect the AC input are located in this drawer. Please see the "FUSES" section of this manual for more information.
3. DC FUSES. These two fuses protect the internal DC power supplies. Please see the "FUSES" sections of this manual for more information.

BASIC TEST ARRANGEMENT

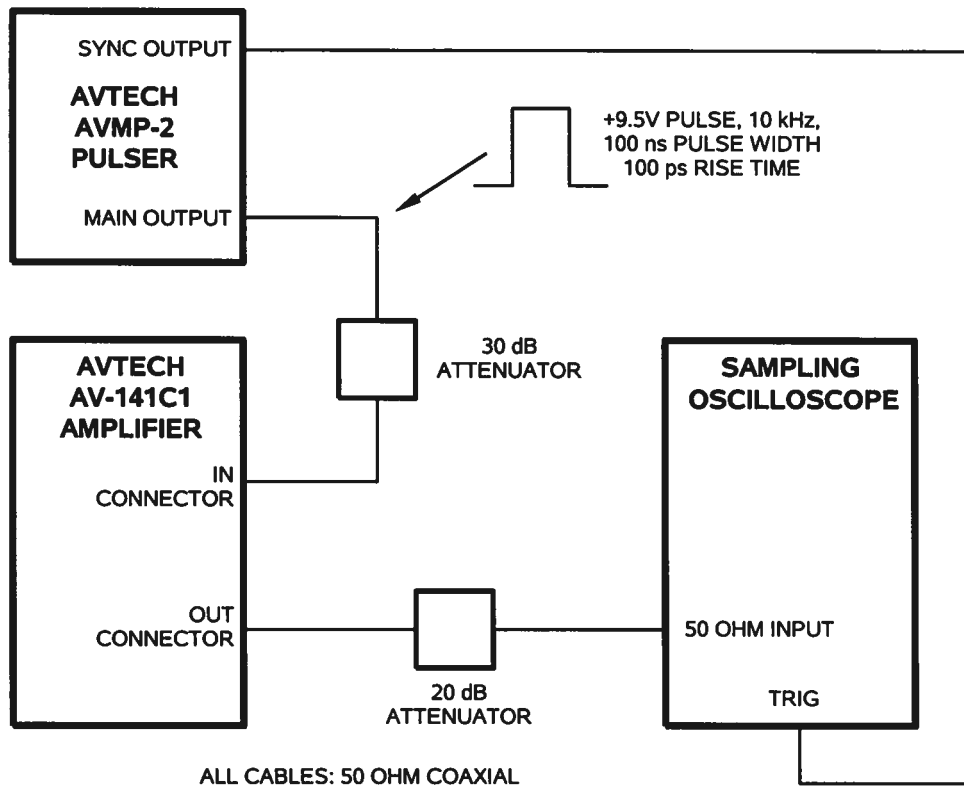

The recommended test set-up is shown above.

The Avtech AVMP-2 series can be used to generate a +9.5V pulse at 10 kHz, with 100 ns pulse width. The rise time will be 100 ps. The 30 dB attenuator will reduce this signal to 300 mV.

The AV-141C1-PS amplifier will amplify the signal to 3V. The output rise time should be 800 ps or less. (Note that if a slower input signal is used, the observed output signal will be correspondingly slower.)

A 20 dB attenuator should be placed at the input of the oscilloscope, to avoid over-driving the input. Most high-bandwidth sampling oscilloscopes do not tolerate inputs of more than $\pm 1V$.

The bandwidth capability of components and instruments used to display the pulse generator output signal (attenuators, cables, connectors, etc.) should exceed several gigahertz.

PROTECTING YOUR INSTRUMENT

 To obtain maximum performance, the input of the AV-141C1-PS is not protected against excessive input voltages. The input signal **MUST NOT EXCEED ± 300 mV!** It may be damaged by voltages greater than ± 300 mV. Failures due to the application of excessive input voltages are not covered by warranty.

WIRING DIAGRAMS

WIRING OF AC POWER

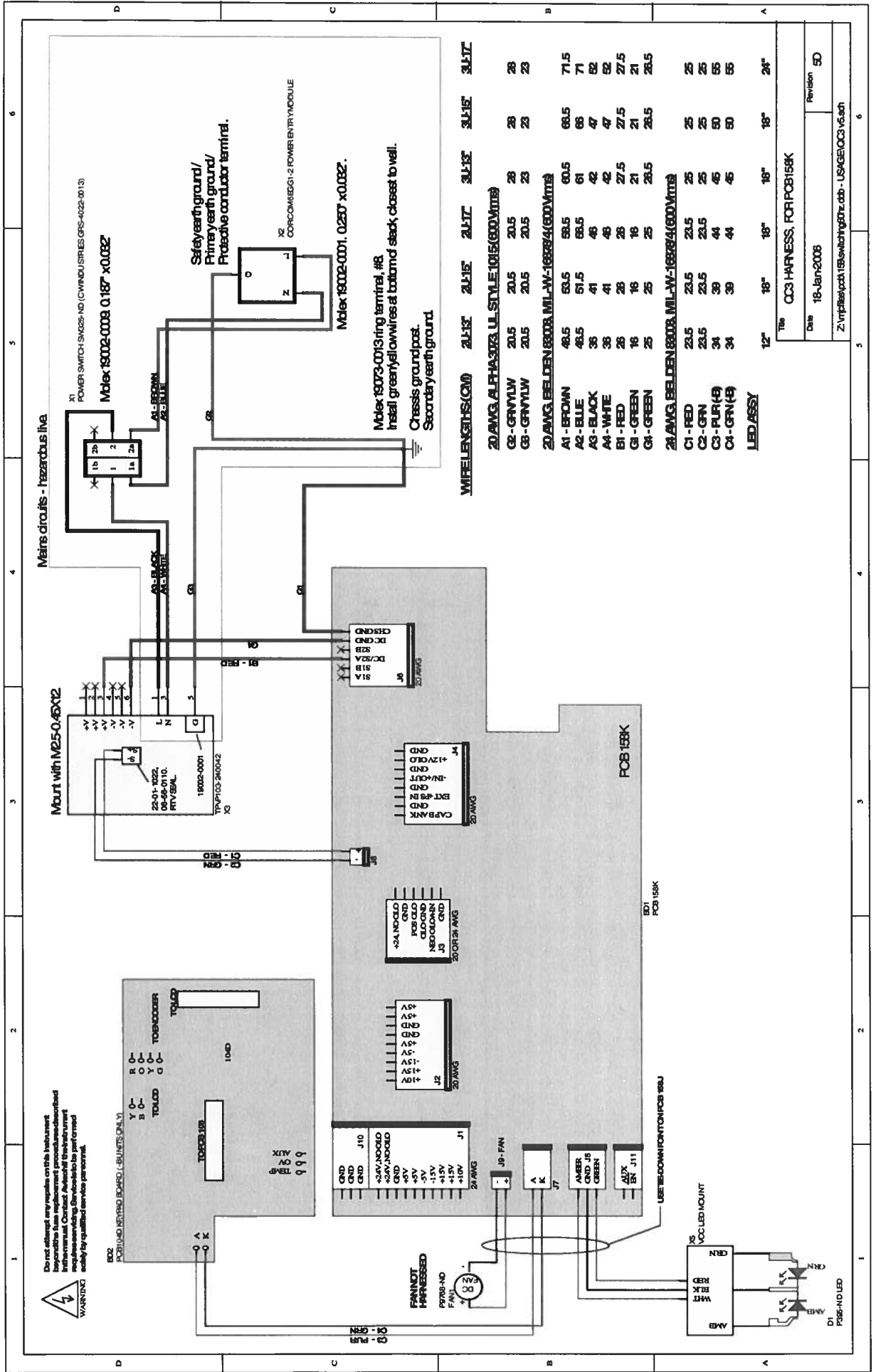

PCB 158K - LOW VOLTAGE POWER SUPPLY, 1/3

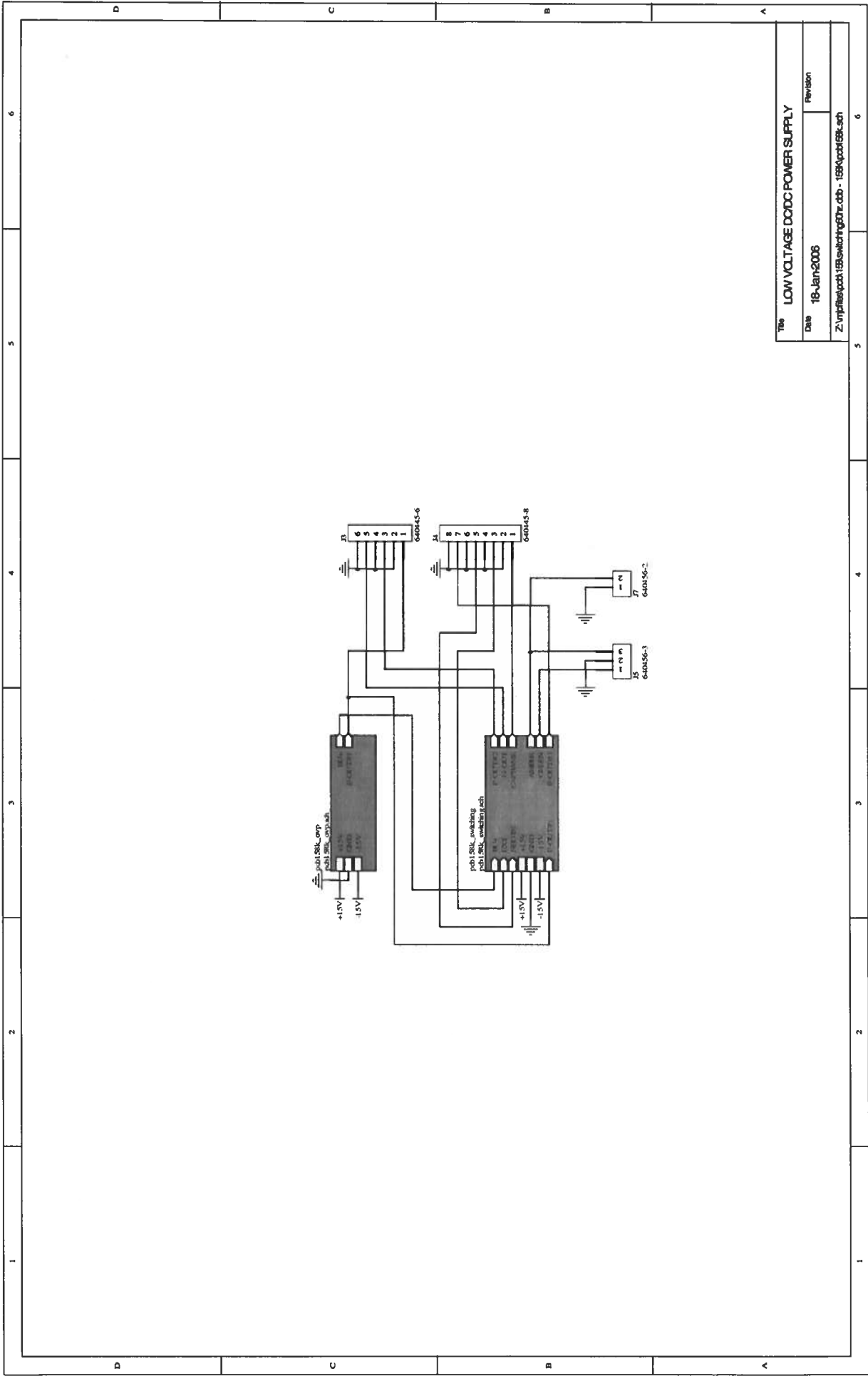

Title		LOW VOLTAGE DCDC POWER SUPPLY
Date	18-Jan-2006	Revision
Z:\v\pfiles\pcb158\switching07r.dcb - 158k\pcb158k.sch		

PCB 158K - LOW VOLTAGE POWER SUPPLY, 2/3

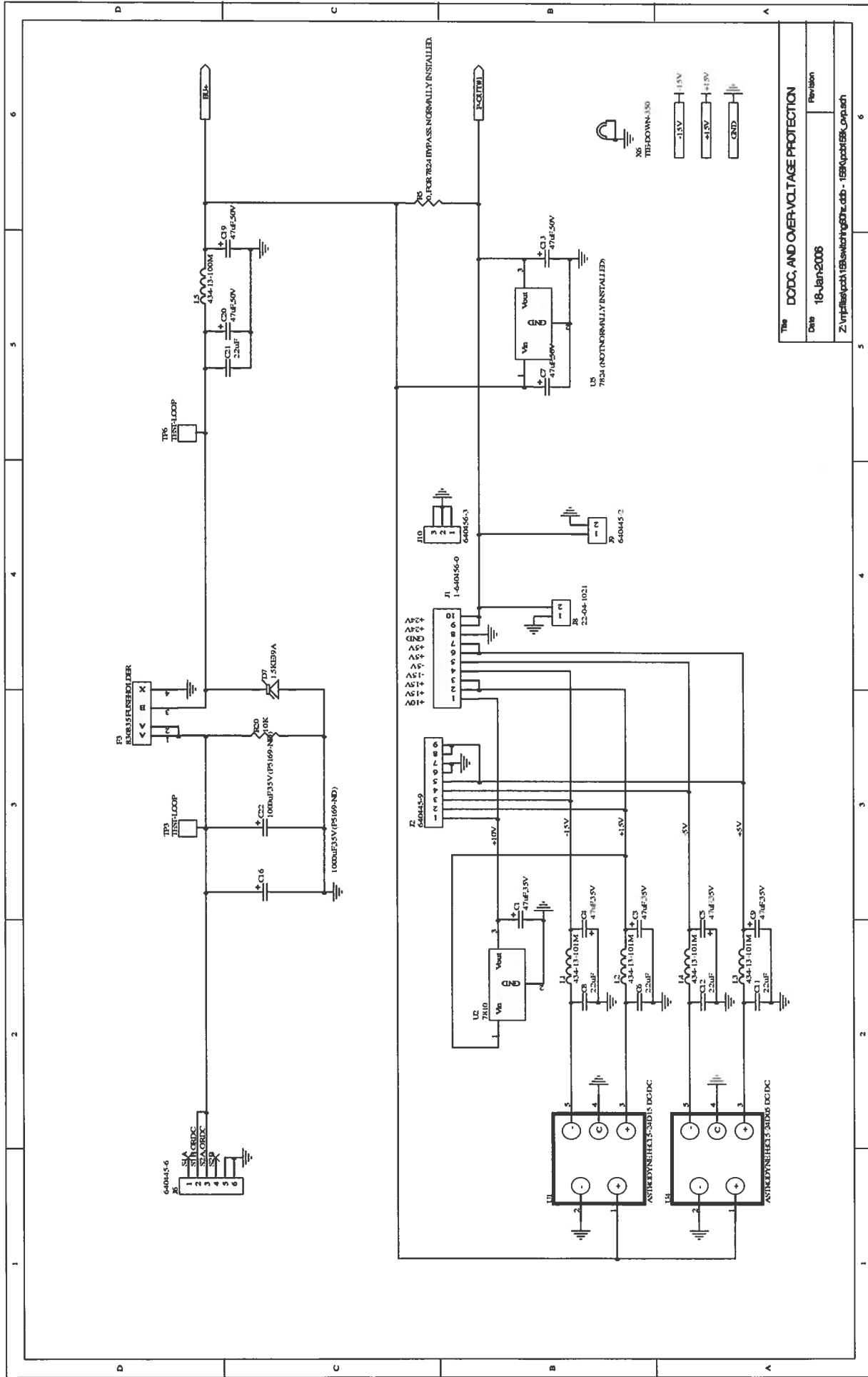

The	
DCDC, AND OVERVOLTAGE PROTECTION	Revision
Date	18-Jan-2005
Z:\vpl\aspl\pcb158\switching67hr.ccb - 158k\update5E_cop.nch	

PCB 158K - LOW VOLTAGE POWER SUPPLY, 3/3

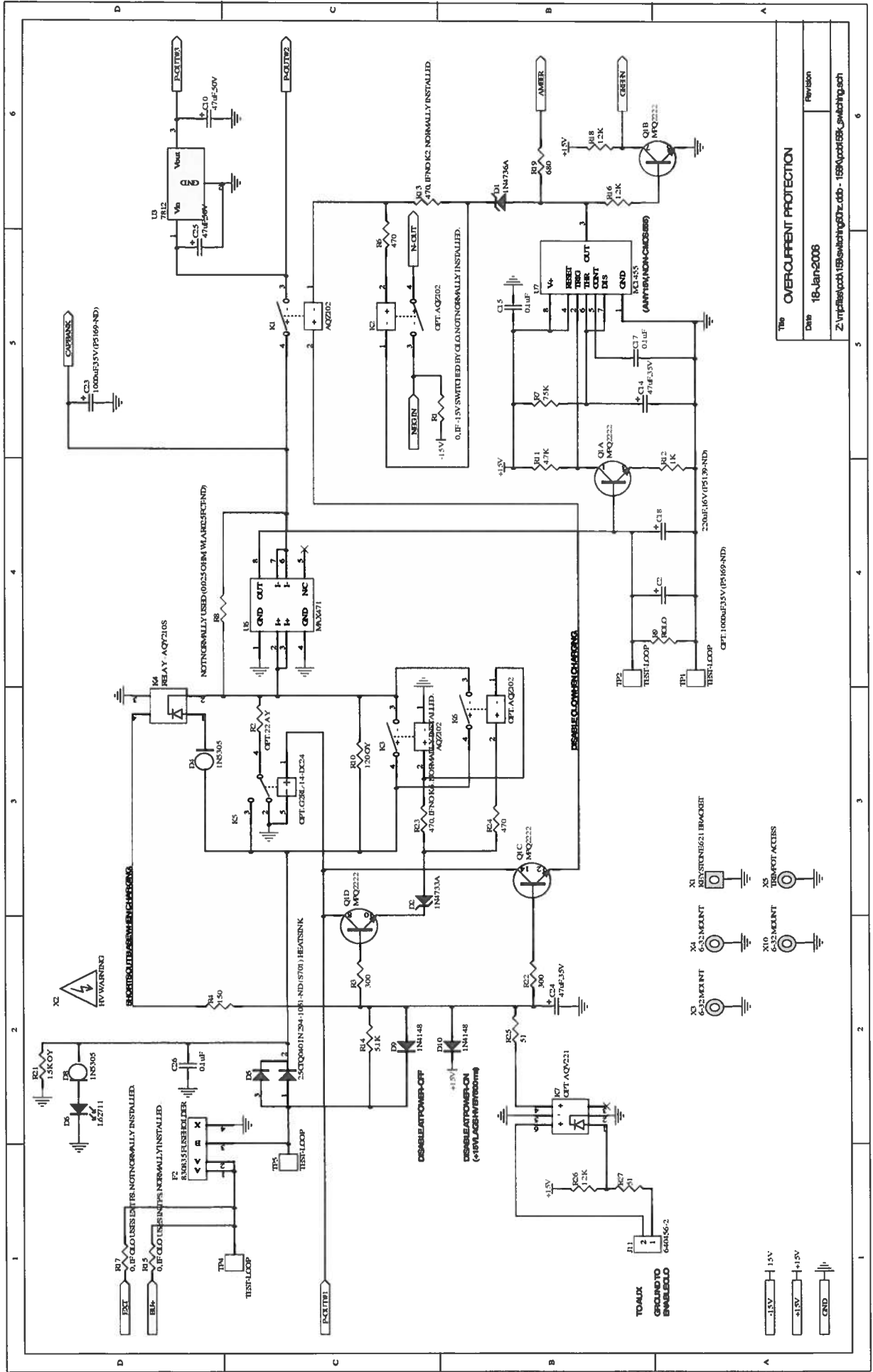

Title: OVERCURRENT PROTECTION	
Date: 18-Jan-2008	Revision:
Z:\vpl\ps\p\ch1185sw\chng07z.dbb - 158k\pcb158k_sw\chng1.pcb	

1 2 3 4 5 6

A B C D



MAIN WIRING

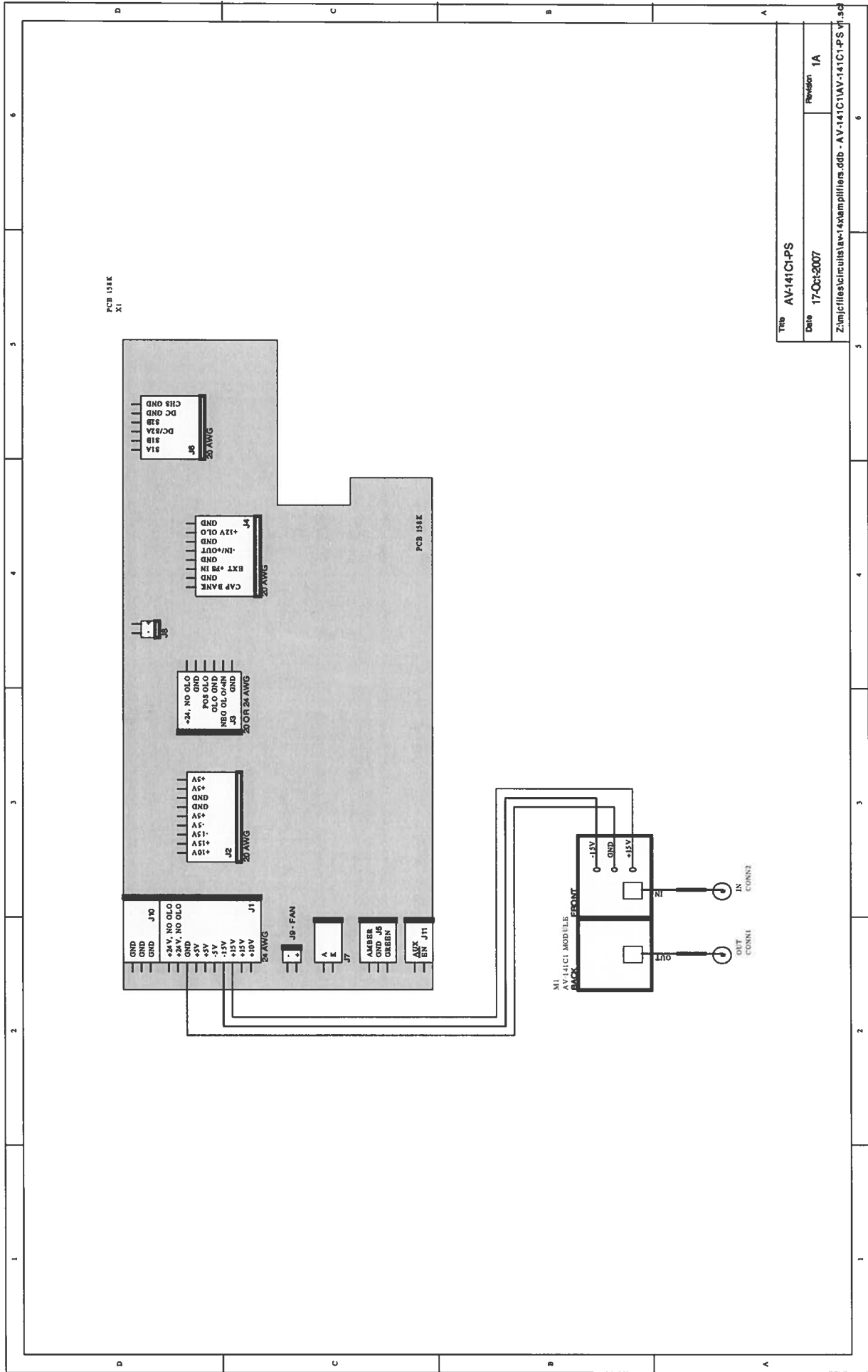

Trid	AV-141C1-PS
Date	17-Oct-2007
Revision	1A

Z:\mjc\files\circuitis\av-141c1\ps\141c1-ps.vi.sch

04/17/07