



AVTECH ELECTROSYSTEMS LTD.

NANOSECOND WAVEFORM ELECTRONICS
SINCE 1975

P.O. BOX 265
OGDENSBURG, NY
U.S.A. 13669-0265
TEL: (315) 472-5270
FAX: (613) 226-2802

TEL: 1-800-265-6681
FAX: 1-800-561-1970

e-mail: info@avtechpulse.com
<http://www.avtechpulse.com>

P.O. BOX 5120 STN. F
OTTAWA, ONTARIO
CANADA K2C 3H4
TEL: (613) 226-5772
FAX: (613) 226-2802

Noise spec
must be
updated
- July 13/01

INSTRUCTIONS

MODEL AV-145D-PS

0 to $\pm 5V$ IN,

0 to $\pm 20V$ OUT, TO 50 OHMS,

VARIABLE-GAIN AMPLIFIER

SERIAL NUMBER: _____

WARRANTY

Avtech Electrosystems Ltd. warrants products of its manufacture to be free from defects in material and workmanship under conditions of normal use. If, within one year after delivery to the original owner, and after prepaid return by the original owner, this Avtech product is found to be defective, Avtech shall at its option repair or replace said defective item. This warranty does not apply to units which have been disassembled, modified or subjected to conditions exceeding the applicable specifications or ratings. This warranty is the extent of the obligation assumed by Avtech with respect to this product and no other warranty or guarantee is either expressed or implied.

TECHNICAL SUPPORT

Phone: 613-226-5772 or 1-800-265-6681

Fax: 613-226-2802 or 1-800-561-1970

E-mail: info@avtechpulse.com

World Wide Web: <http://www.avtechpulse.com>

TABLE OF CONTENTS

WARRANTY	2
TECHNICAL SUPPORT	2
TABLE OF CONTENTS	3
INTRODUCTION	4
SPECIFICATIONS	4
INSTALLATION	5
VISUAL CHECK	5
PLUGGING IN THE INSTRUMENT	5
FRONT PANEL CONTROLS	6
REAR PANEL CONTROLS	7
GENERAL INFORMATION	8
BASIC OPERATION	8
OPERATIONAL CHECK	9
USAGE PRECAUTIONS	10
POWER SUPPLY AND FUSE REPLACEMENT	11
PERFORMANCE CHECK SHEET	13

INTRODUCTION

The AV-145D-PS amplifier has an adjustable gain (V_{OUT}/V_{IN}) of -20 dB to +20 dB. The gain is controlled by a voltage applied to a rear-panel BNC connector. A voltage of 0 on this connector corresponds to -20 dB gain ($\times 0.1$ voltage gain), and a voltage of +5V corresponds to +20 dB gain ($\times 10$ voltage gain).

The input may range from 0 to $\pm 5V$. The input impedance is 50Ω . The maximum output range is 0 to $\pm 20V$, into load impedances of 50Ω or greater.

The output rise and fall times are 50 ns or less.

SPECIFICATIONS

Model:	AV-145D-PS
Bandwidth:	DC-10 MHz
Gain:	-20 to +20 dB ($\times 0.1$ to $\times 10$ voltage)
Peak output:	$\pm 20 V$
Maximum input:	$\pm 5 V$
Gain control Bandwidth ¹ :	5 MHz
Gain control voltage:	0 to +5 Volt input. Input impedance $> 10 k\Omega$.
Input noise voltage:	$25 nV/\sqrt{Hz}$
Rise, fall time:	50 ns
Input impedance:	Input: 50 Ohms
Connectors:	SMA
Prime power:	120/240 Volts (switchable), 50 - 60 Hz
Dimensions:	100 mm x 215 mm x 375 mm (3.9" x 8.5" x 14.8")

¹⁾ Refers to the rate at which the gain may be varied. This is unrelated to the bandwidth of the output.

INSTALLATION

VISUAL CHECK

After unpacking the instrument, examine to ensure that it has not been damaged in shipment. Visually inspect all connectors, knobs, and handles. Confirm that a power cord and this manual are with the instrument. If the instrument has been damaged, file a claim immediately with the company that transported the instrument.

PLUGGING IN THE INSTRUMENT

Examine the rear of the instrument. There will be a male power receptacle, a fuse holder and the edge of the power selector card visible.

For AC line voltages of 110-120V, the power selector card should be installed so that the "120" marking is visible from the rear of the instrument.

For AC line voltages of 220-240V, the power selector card should be installed so that the "240" marking is visible from the rear of the instrument.

If it is not set for the proper voltage, remove the fuse and then grasp the card with a pair of pliers and remove it. Rotate horizontally through 180 degrees. Reinstall the card and the correct fuse.

In the 120V setting, a 0.5A slow blow fuse is required. In the 240V setting, a 0.25A slow-blow fuse is required.

FRONT PANEL CONTROLS

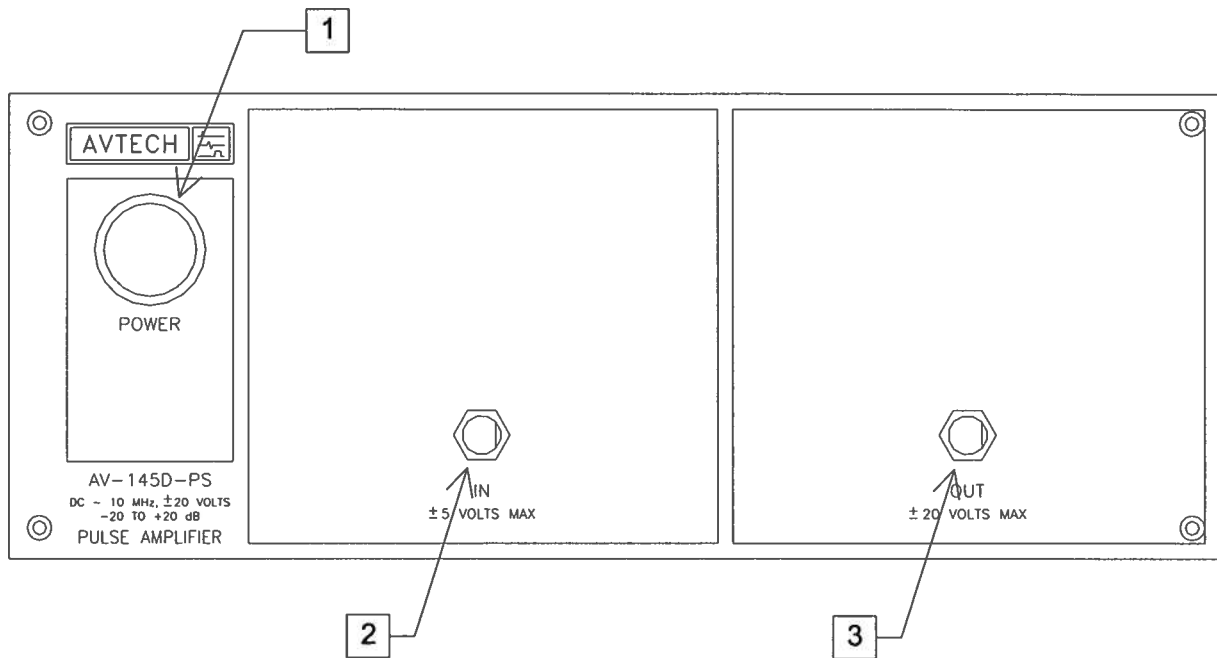

1. **POWER Switch.** The POWER push button switch applies AC prime power to the primaries of the transformer, turning the instrument on. The push button lamp (#382 type) is connected to the +15V DC supply.
2. **IN CONNECTOR.** The input signal to be amplified is applied to this SMA connector. The input should not exceed $\pm 5V$. The input impedance is 50Ω .
3. **OUT CONNECTOR.** This SMA connector provides the main output signal. This output can supply up to $\pm 20V$ into a 50Ω (or greater) load. The output impedance is approximately 2Ω .

REAR PANEL CONTROLS

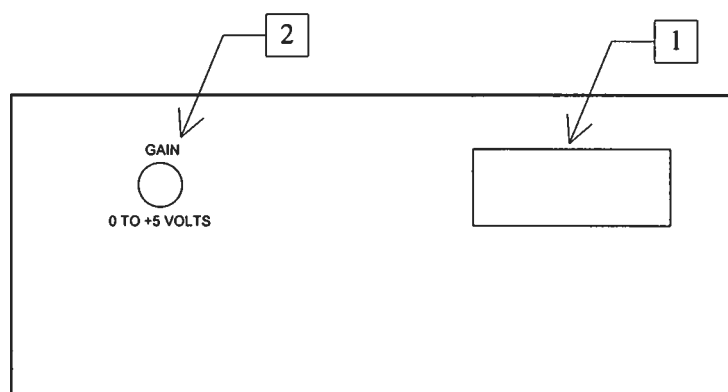

1. **AC POWER INPUT.** A three-pronged recessed male connector is provided on the back panel for AC power connection to the instrument. Also contained in this assembly is a 0.5A slow blow fuse and a removable card that can be removed and repositioned to switch between 120V AC in and 240V AC in.

For AC line voltages of 110-120V, the power selector card should be installed so that the "120" marking is visible from the rear of the instrument.

For AC line voltages of 220-240V, the power selector card should be installed so that the "240" marking is visible from the rear of the instrument.

If it is not set for the proper voltage, remove the fuse and then grasp the card with a pair of pliers and remove it. Rotate horizontally through 180 degrees. Reinstall the card and the correct fuse.

In the 120V setting, a 0.5A slow blow fuse is required. In the 240V setting, a 0.25A slow-blow fuse is required.

2. **GAIN Control Voltage Connector.** A voltage is applied to this connector to control the gain of the amplifier. A voltage of 0 on this connector corresponds to -20 dB gain ($\times 0.1$ voltage gain), and a voltage of +5V corresponds to +20 dB gain ($\times 10$ voltage gain). The voltage gain (V_{OUT}/V_{IN}) varies linearly with this control voltage. The input impedance of this connector is $> 10 \text{ k}\Omega$.

GENERAL INFORMATION

BASIC OPERATION

This instrument is very straightforward to connect and operate. The input signal is connected to the "IN" connector, and the output signal is generated by the amplifier on the "OUT" connector. A gain control voltage in the range of 0 to +5V (typically generated by a DC power supply, or a computer card) is applied to the "GAIN" connector.

The basic test arrangement is shown below:

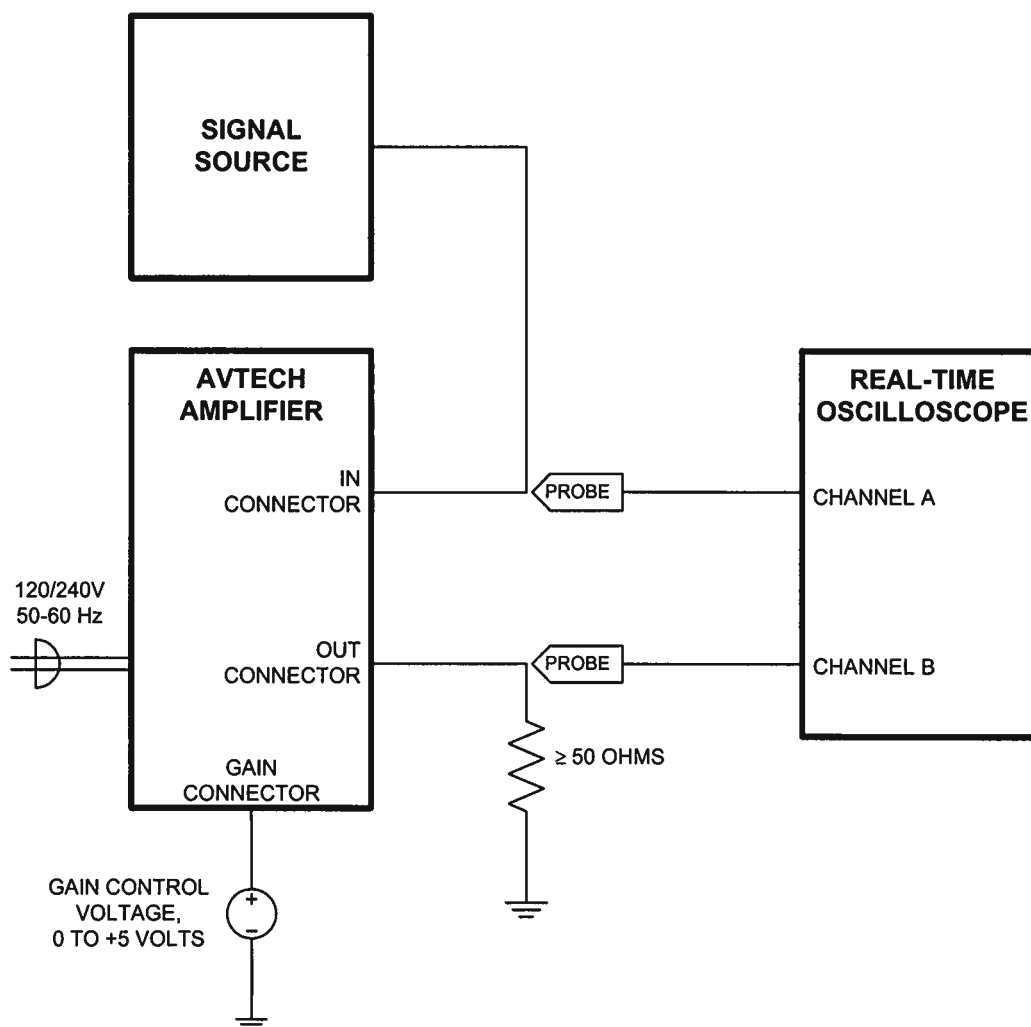

OPERATIONAL CHECK

To confirm the operation of the instrument, connect the amplifier as shown on the previous page. Use a signal source capable of generating a 0 to +2V pulse, with rise and fall times of less than 10 ns, and a pulse width of approximately 500 ns. (The Avtech AV-1000-C pulse generator is suitable for this purpose). Attach a DC power supply, capable of generating 0 to +5V, to the GAIN control input.

Confirm that the oscilloscope properly displays the input signal. Then turn on the Avtech amplifier, and observe the output signal on the oscilloscope. Set the gain control voltage to +5V. The output amplitude should be approximately +20V, with rise and fall times of 50 ns (when measured between the 20% and 80% amplitude points of each edge).

Note that if the rise and fall times of the input signal are longer than 10 ns, the output rise and fall times will increase correspondingly.

If additional assistance is required, contact:

Tel: (613) 226-5772, Fax: (613) 226-2802
Email: info@avtechpulse.com

USAGE PRECAUTIONS

The unit may be damaged if operated into a short circuit. Such failures are not covered by the warranty. The load impedance must be equal to or greater than 50 Ohms.

The input may be damaged if input voltages greater than $\pm 5V$ are applied.

The gain control voltage must lie between 0 and +5 Volts. The instrument may be damaged by voltages outside of this range.

Never apply an external voltage to the output, or the output may be damaged.

POWER SUPPLY AND FUSE REPLACEMENT

This instrument has three main fuses, plus two spares. One, which protects the AC input, is located in the rear-panel power entry module, as described in the “Rear Panel Controls” section of this manual. If the power appears to have failed, check the AC fuse first.

The other two fuses (plus two spares) are located on the internal DC power supply, as shown below:

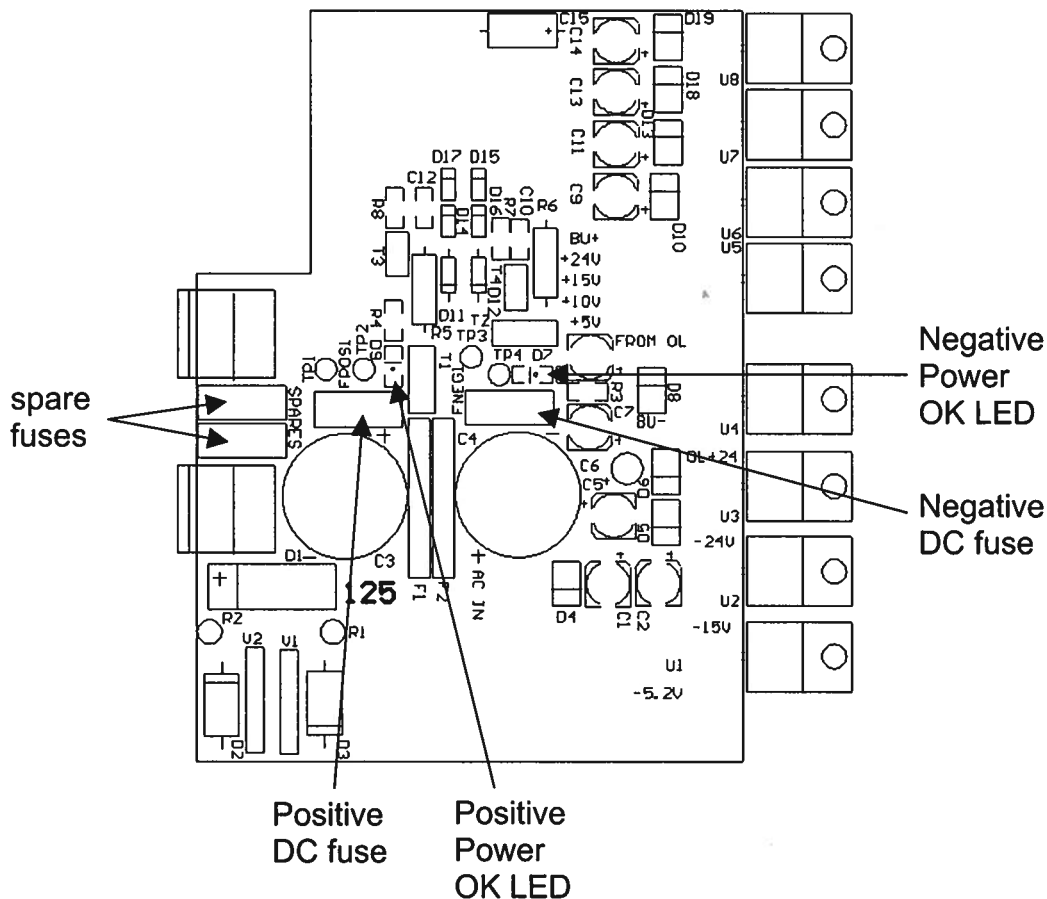

The four fuses on this circuit board are 1A slow-blow fuses, Littlefuse part number R452001. (This fuse can be ordered from Digikey, www.digikey.com. The Digikey part number is F1343CT-ND).

If you suspect that the DC fuses are blown, follow this procedure:

1. Remove the top cover, by removing the four Phillips screws on the top cover and then sliding the cover back and off.
2. Locate the two “Power OK” LEDs on the power supply circuit board, as illustrated above.
3. Turn on the instrument.

4. Observe the "Power OK" LEDs. If the fuses are not blown, the two LEDs will be lit (bright red). If one of the LEDs is not lit, the fuse next to it has blown.
5. Turn off the instrument.
6. If a fuse is blown, use needle-nose pliers to remove the blown fuse from its surface-mount holder.

Replace the fuse. (Two spare 1 Amp fuses are provided on the circuit board. They may be transferred to the active fuse locations using needle-nose pliers.)

July 9/2001
(edition 1)