



AVTECH ELECTROSYSTEMS LTD.

NANOSECOND WAVEFORM ELECTRONICS
SINCE 1975

P.O. BOX 265
OGDENSBURG, NY
U.S.A. 13669-0265
TEL: (315) 472-5270
FAX: (613) 226-2802

TEL: 1-800-265-6681
FAX: 1-800-561-1970

e-mail: info@avtechpulse.com
<http://www.avtechpulse.com>

P.O. BOX 5120 STN. F
OTTAWA, ONTARIO
CANADA K2C 3H4
TEL: (613) 226-5772
FAX: (613) 226-2802

INSTRUCTIONS

MODEL AV-149-BW4-2.8K-PIN-SP1-B TRANSIMPEDANCE AMPLIFIER

S.N.:

WARRANTY

Avtech Electrosystems Ltd. warrants products of its manufacture to be free from defects in material and workmanship under conditions of normal use. If, within one year after delivery to the original owner, and after prepaid return by the original owner, this Avtech product is found to be defective, Avtech shall at its option repair or replace said defective item. This warranty does not apply to units which have been disassembled, modified or subjected to conditions exceeding the applicable specifications or ratings. This warranty is the extent of the obligation assumed by Avtech with respect to this product and no other warranty or guarantee is either expressed or implied.

TECHNICAL SUPPORT

Phone: 613-226-5772 or 1-800-265-6681

Fax: 613-226-2802 or 1-800-561-1970

E-mail: info@avtechpulse.com

World Wide Web: <http://www.avtechpulse.com>

TABLE OF CONTENTS

WARRANTY.....	2
TABLE OF CONTENTS	3
FIG. 1: PULSE GENERATOR TEST ARRANGEMENT	4
GENERAL OPERATING INSTRUCTIONS	5
FIG. 2: DIODE SOCKET PIN CONNECTIONS.....	6

FIG. 1: PULSE GENERATOR TEST ARRANGEMENT

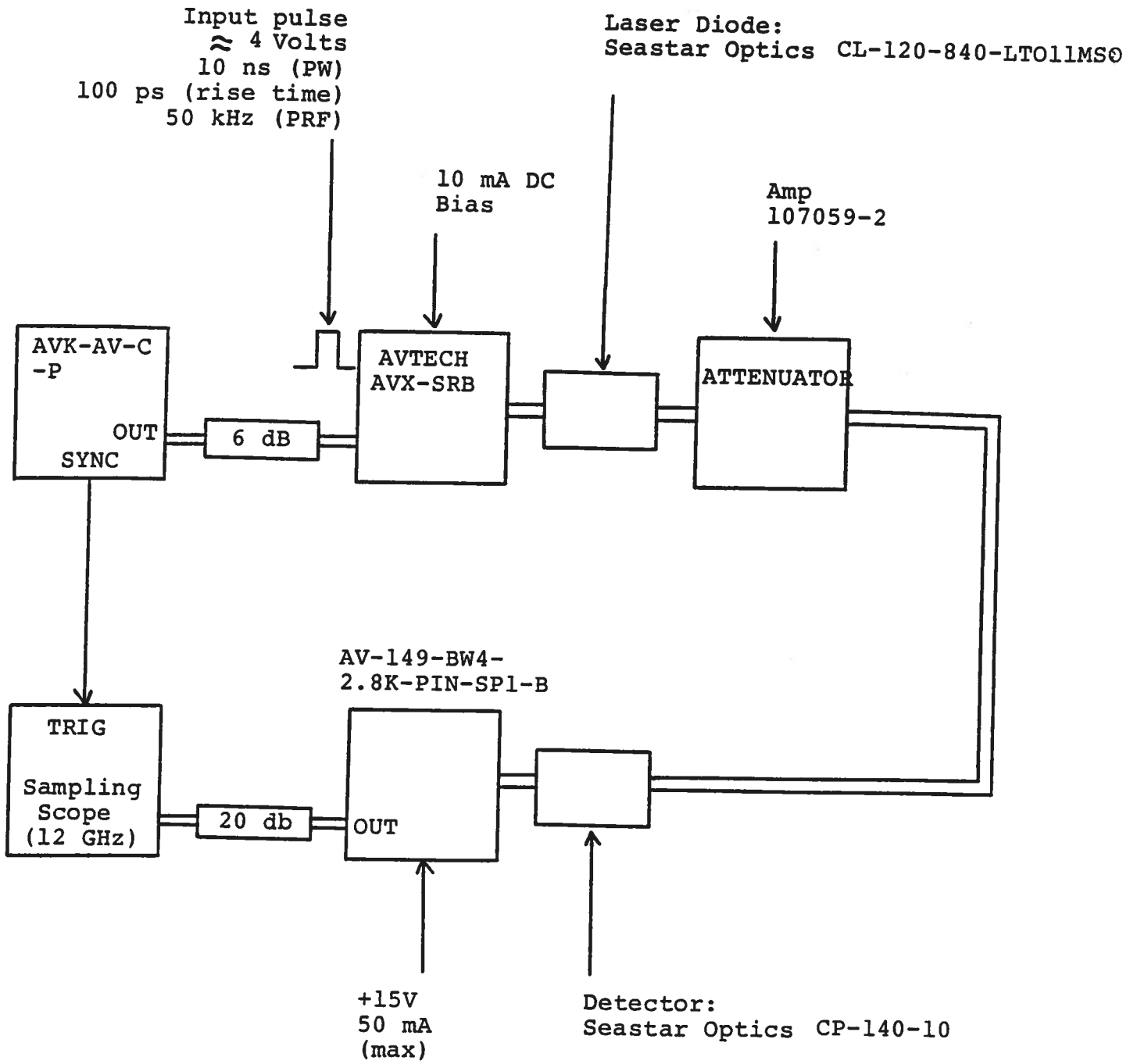

GENERAL OPERATING INSTRUCTIONS

- 1) The basic operation of the amplifier was confirmed using the pulse mode test arrangement shown in Fig. 1.
- 2) The AV-149 amplifier requires a prime power of +15 VDC (100 mA max).
- 3) **CAUTION:** The amplifier will be damaged if the anode and cathode connections are reversed.
- 4) The leads of the photo diode should not be inserted more than 1.0 cm into the socket.
- 5) The +15 VDC supply should be turned off when installing or removing the photo diode.
- 6) To test the AV-149 in a sweep frequency mode (10 MHz to 1200 MHz) the AVK-AV-C and the sampling scope should be replaced by a network analyzer.
- 7) For additional information:

Tel: (613) 226-5772

Fax: (613) 226-2802

FIG. 2: DIODE SOCKET PIN CONNECTIONS

- 1) ANODE
- 2) CASE
- 3) CATHODE

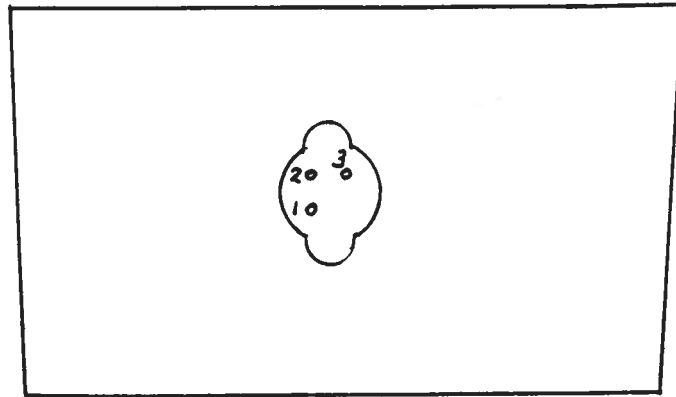

Nov 2/98

Edition B

instructwerd | av-149 | av-149-BW4.2.8K-PIN-SP1-b-edb.doc