



AVTECH ELECTROSYSTEMS LTD.

NANOSECOND WAVEFORM ELECTRONICS
SINCE 1975

□ P.O. BOX 265
OGDENSBURG, NY
U.S.A. 13669-0265
TEL: (315) 472-5270
FAX: (613) 226-2802

TEL: 1-800-265-6681
FAX: 1-800-561-1970

e-mail: info@avtechpulse.com
<http://www.avtechpulse.com>

□ P.O. BOX 5120 STN. F
OTTAWA, ONTARIO
CANADA K2C 3H4
TEL: (613) 226-5772
FAX: (613) 226-2802

INSTRUCTIONS

MODEL AVB2-TB-C-EF-EA MONOCYCLE GENERATOR

S.N.:

WARRANTY

Avtech Electrosystems Ltd. warrants products of its manufacture to be free from defects in material and workmanship under conditions of normal use. If, within one year after delivery to the original owner, and after prepaid return by the original owner, this Avtech product is found to be defective, Avtech shall at its option repair or replace said defective item. This warranty does not apply to units which have been disassembled, modified or subjected to conditions exceeding the applicable specifications or ratings. This warranty is the extent of the obligation assumed by Avtech with respect to this product and no other warranty or guarantee is either expressed or implied.

TECHNICAL SUPPORT

Phone: 613-226-5772 or 1-800-265-6681

Fax: 613-226-2802 or 1-800-561-1970

E-mail: info@avtechpulse.com

World Wide Web: <http://www.avtechpulse.com>

TABLE OF CONTENTS

WARRANTY	2
TABLE OF CONTENTS	3
FIG. 1: PULSE GENERATOR TEST ARRANGEMENT.....	4
GENERAL OPERATING INSTRUCTIONS	5
Fig. 2: FRONT PANEL CONTROLS	7
FRONT PANEL CONTROLS	8
Fig. 3: BACK PANEL CONTROLS.....	10
BACK PANEL CONTROLS.....	11
TOP COVER REMOVAL AND RACK MOUNTING.....	12
ORIGINAL QUOTATION.....	13
PERFORMANCE CHECK SHEET	14

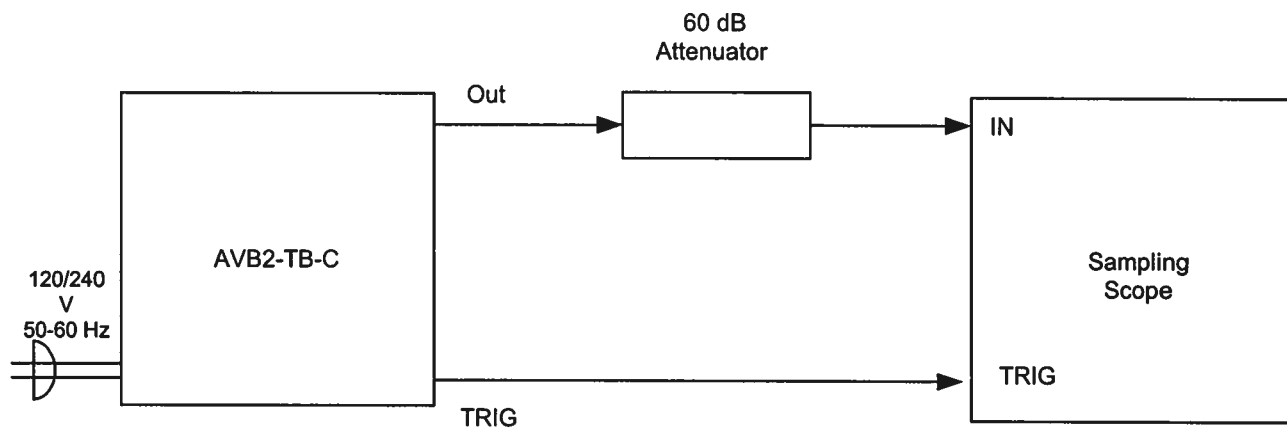
FIG. 1: PULSE GENERATOR TEST ARRANGEMENT

GENERAL OPERATING INSTRUCTIONS

- 1) The bandwidth capability of components and instruments used to display the pulse generator output signal (attenuators, cables, connectors, etc.) should exceed one gigahertz.
- 2) This unit requires a 50-Ohm load impedance. The use of 60-db attenuator at the sampling scope vertical input channel will insure a peak input signal to the sampling scope of less than one volt. If a high impedance scope is used the attenuator must be replaced by a shunt 50-Ohm load resistor.
- 3) The TRIG output channel provides TTL level signals (100ns).
- 4) The output frequency is controlled by the front panel ten-turn FREQUENCY control. Clockwise rotation of the control increases the frequency of the output monocyte (or decreases the pulse width of the output waveform). The unit may require a short warm-up period (≤ 5 mins) before the output frequency stabilizes. To voltage control the frequency, set the rear panel switch in the EXT position and apply 0 to +10V to the "A" BNC connector ($R_{IN} \geq 10K$). (Option).
- 5) To obtain a stable output display the PRF control on the front panel should be set mid range. The front panel MODE switch should be in the INT position. The DELAY controls and the scope triggering controls are then adjusted to obtain a stable output. The scope may then be used to set the desired PRF by rotating the PRF controls.
- 6) The output pulse amplitude is controlled by means of the front panel ten-turn AMP control. To voltage control the output amplitude, set the rear panel switch in the EXT position and apply 0 to +10V to the "A" BNC connector ($R_{IN} \geq 10K$). (Option).
- 7) An external clock may be used to control the output PRF of the AVB2 unit by setting the front panel MODE switch in the EXT position and applying a 50 ns (or wider) TTL level pulse to the TRIG BNC connector input.
- 8) For single pulse manual operation, set the front panel MODE switch in the MAN position and push the SINGLE PULSE button.
- 9) MONITOR Output. The rear panel monitor output provides an attenuated replica (20 db down) of the output. The monitor output is designed to operate into a 50-ohm load. (option).

- 10) The unit can be converted from 120 to 240V 50-60 Hz operation by adjusting the voltage selector card in the rear panel fused voltage selector-cable connector assembly.
- 11) **CAUTION.** DC potentials as high as 395 Volts exist in the interior of the instrument. For this reason it is recommended that the top cover of the unit should not be removed and that the unit should be returned to the factory for servicing (when necessary).
- 12) For additional information:

Tel: (613) 226-5772
Fax: (613) 226-2802
Email: info@avtechpulse.com

Fig. 2: FRONT PANEL CONTROLS

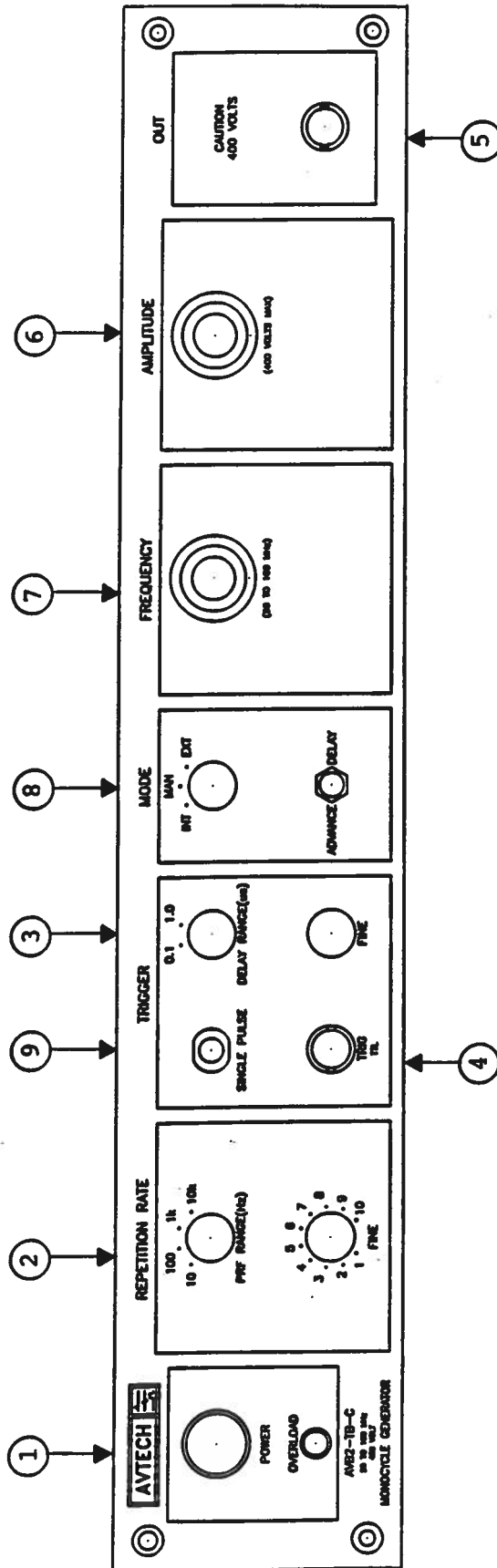

FRONT PANEL CONTROLS

- (1) ON-OFF Switch. Applies basic prime power to all stages.
- (2) PRF Control. The PRF RANGE and PRF controls determine output PRF as follows:

	PRF MIN	PRF MAX
Range 1	1 Hz	10 Hz
Range 2	10 Hz	100 kHz
Range 3	100 Hz	1 kHz
Range 4	1 kHz	10 kHz

- (3) DELAY Control. Controls the relative delay between the reference output pulse provided at the TRIG output (4) the main output (5). This delay is variable over the range of 0 to about 1.0 μ s. Delay LEADS and LAGS depending on the position of the ADVANCE-DELAY switch.
- (4) TRIG Output. This output is used to trigger the scope time base. The output is a TTL level 100 ns (approx.) pulse capable of driving a fifty ohm load. This output precedes the output at (5) if the two position ADVANCE-DELAY switch is in the ADVANCE position. This output follows the output at (5) if the switch is in the DELAY position. The external trigger signal is applied at this input when the MODE switch is in the EXT position.
- (5) OUT. BNC connector applies output to 50-ohm load. Note that this unit requires a 50 ohm load
- (6) AMP Control. The output pulse amplitude is controlled by means of the ten-turn control.
- (7) FREQUENCY: Ten-turn control varies the frequency from 50 to 100 MHz.
- (8) MODE. With this switch in the INT position, the PRF of the AVB2 unit is controlled via an internal clock, which in turn is controlled by the PRF controls. With the switch in the EXT position, the AVB2 unit requires a 50 ns (or wider) TTL level pulse applied at the TRIG input in order to trigger the output stages. In addition, in this mode, the scope time base must be triggered by the external trigger source.

- (9) SINGLE PULSE. For single pulse manual operation, set the front panel MODE switch in the MAN position and push the SINGLE PULSE button.

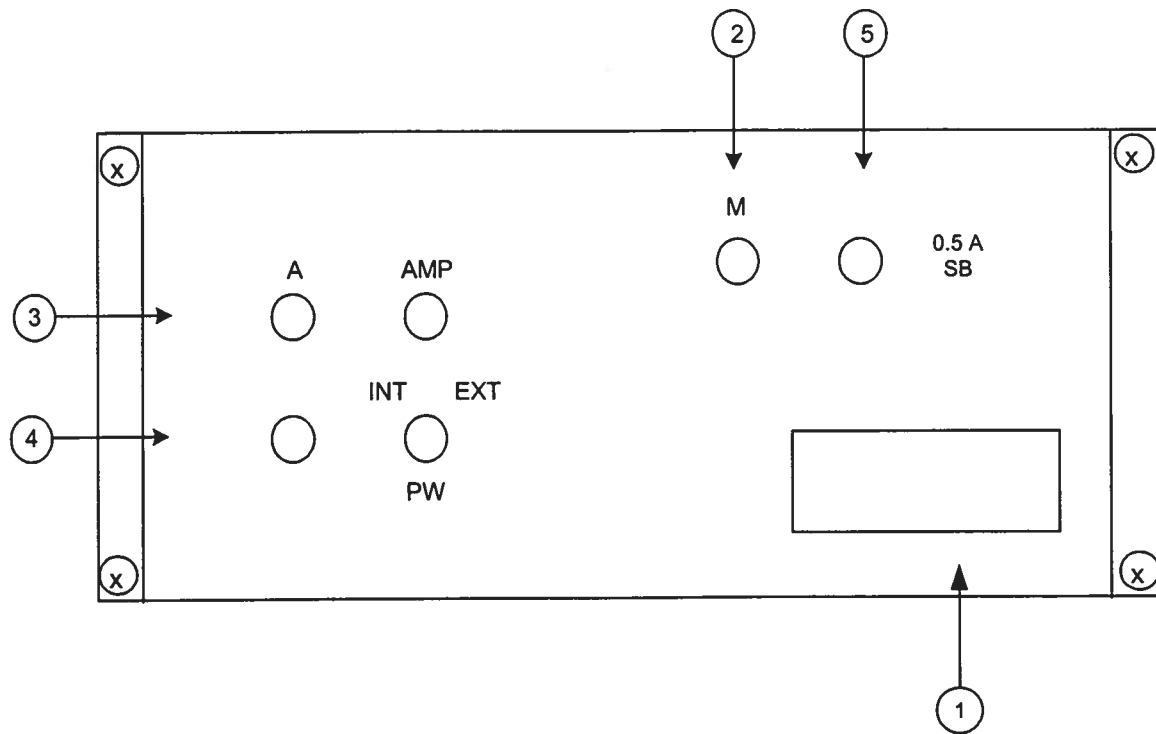
Fig. 3: BACK PANEL CONTROLS

BACK PANEL CONTROLS

- (1) FUSED CONNECTOR, VOLTAGE SELECTOR. The detachable power cord is connected at this point. In addition, the removable cord is adjusted to select the desired input operating voltage. The unit also contains the main power fuse.

For AC line voltages of 110-120V, the power selector card should be installed so that the "120" marking is visible from the rear of the instrument.

For AC line voltages of 220-240V, the power selector card should be installed so that the "240" marking is visible from the rear of the instrument.

If it is not set for the proper voltage, remove the fuse and then grasp the card with a pair of pliers and remove it. Rotate horizontally through 180 degrees. Reinstall the card and the correct fuse.

In the 120V setting, a 1.0A slow blow fuse is required. In the 240V setting, a 0.5A slow blow fuse is required.

- (2) MONITOR OPTION. Provides an attenuated (x10) coincident replica of the main output. Must be terminated in 50 Ohms when in use.
- (3) AMP. To voltage control the output amplitude, set this switch in the EXT position and apply 0 to +10V to the "A" BNC connector ($R_{IN} > 10K$). (Option).
- (4) PW. To voltage control the frequency, set this switch in the EXT position and apply 0 to +10V to the "A" BNC connector ($R_{IN} > 10K$). (Option).
- (5) 0.5 ASB. This fuse limits the power supplied to the output stage.

TOP COVER REMOVAL AND RACK MOUNTING

- 1) The interior of the instrument may be accessed by removing the four Philips screws on the top panel. With the four screws removed, the top cover may be slid back (and off).
- 2) The -R5 rack mount kit may be installed after first removing the one Philips screw on the side panel adjacent to the front handle.

April 7, 2003