



AVTECH ELECTROSYSTEMS LTD.

NANOSECOND WAVEFORM ELECTRONICS
SINCE 1975

□ P.O. BOX 265
OGDENSBURG, NY
U.S.A. 13669-0265
TEL: (315) 472-5270
FAX: (613) 226-2802

TEL: 1-800-265-6681
FAX: 1-800-561-1970

e-mail: info@avtechpulse.com
<http://www.avtechpulse.com>

□ P.O. BOX 5120 STN. F
OTTAWA, ONTARIO
CANADA K2C 3H4
TEL: (613) 226-5772
FAX: (613) 226-2802

INSTRUCTIONS

MODEL AVD MONOCYCLE GENERATOR

S.N.:

WARRANTY

Avtech Electrosystems Ltd. warrants products of its manufacture to be free from defects in material and workmanship under conditions of normal use. If, within one year after delivery to the original owner, and after prepaid return by the original owner, this Avtech product is found to be defective, Avtech shall at its option repair or replace said defective item. This warranty does not apply to units which have been disassembled, modified or subjected to conditions exceeding the applicable specifications or ratings. This warranty is the extent of the obligation assumed by Avtech with respect to this product and no other warranty or guarantee is either expressed or implied.

TECHNICAL SUPPORT

Phone: 613-226-5772 or 1-800-265-6681

Fax: 613-226-2802 or 1-800-561-1970

E-mail: info@avtechpulse.com

World Wide Web: <http://www.avtechpulse.com>

TABLE OF CONTENTS

WARRANTY.....	2
TABLE OF CONTENTS	3
MONOCYCLE GENERATOR TEST ARRANGEMENT.....	4
GENERAL OPERATING INSTRUCTIONS	5
PERFORMANCE CHECK SHEET	6

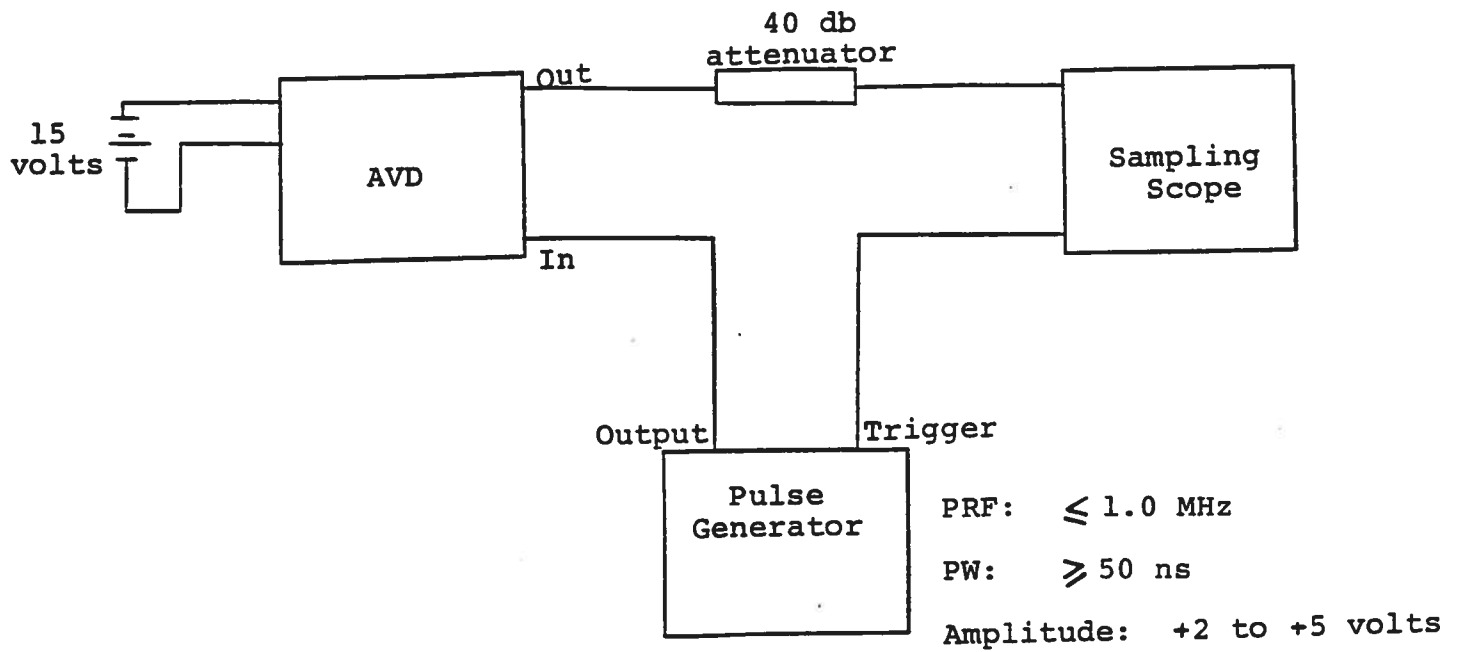
MONOCYCLE GENERATOR TEST ARRANGEMENT

GENERAL OPERATING INSTRUCTIONS

- 1) The bandwidth capability of components and instruments used to display the monocyte generator output signal (attenuators, cables, connectors, etc.) should exceed 10 GHz.
- 2) The use of a 40 db attenuator will insure a peak input signal to the sampling scope of less than one volt.
- 3) In general, the pulse generator delay control should be set in the 100 ns range. Other settings should be as shown in the above diagram. The monocyte generator output is delayed with respect to the trigger input signal by about 75 ns (typically).
- 4) The monocyte generator can withstand an infinite VSWR on the output port.

PERFORMANCE CHECK SHEET

Sept 4/96

Edition B

instructword\ard\avd.doc