



AVTECH ELECTROSYSTEMS LTD.

NANOSECOND WAVEFORM ELECTRONICS
SINCE 1975

P.O. BOX 265
OGDENSBURG, NY
U.S.A. 13669-0265

TEL: 888-670-8729 (USA & Canada) or +1-613-226-5772 (Intl)
FAX: 800-561-1970 (USA & Canada) or +1-613-226-2802 (Intl)

info@avtechpulse.com - <http://www.avtechpulse.com/>

BOX 5120, LCD MERIVALE
OTTAWA, ONTARIO
CANADA K2C 3H4

INSTRUCTIONS

MODEL AVE2

4 V_{PP}, 1 MHz, FIXED TUNED

MONOCYCLE GENERATOR MODULE

SERIAL NUMBER: _____

WARRANTY

Avtech Electrosystems Ltd. warrants products of its manufacture to be free from defects in material and workmanship under conditions of normal use. If, within one year after delivery to the original owner, and after prepaid return by the original owner, this Avtech product is found to be defective, Avtech shall at its option repair or replace said defective item. This warranty does not apply to units which have been disassembled, modified or subjected to conditions exceeding the applicable specifications or ratings. This warranty is the extent of the obligation assumed by Avtech with respect to this product and no other warranty or guarantee is either expressed or implied.

TECHNICAL SUPPORT

Phone: 888-670-8729 (USA & Canada) or +1-613-226-5772 (Intl)

Fax: 800-561-1970 (USA & Canada) or +1-613-226-2802 (Intl)

E-mail: info@avtechpulse.com

World Wide Web: <http://www.avtechpulse.com>

TABLE OF CONTENTS

WARRANTY.....	2
TECHNICAL SUPPORT.....	2
TABLE OF CONTENTS.....	3
INTRODUCTION.....	4
SPECIFICATIONS.....	5
EUROPEAN REGULATORY NOTES.....	6
EC DECLARATION OF CONFORMITY.....	6
DIRECTIVE 2002/95/EC (RoHS).....	6
DIRECTIVE 2002/96/EC (WEEE).....	6
BASIC TEST ARRANGEMENT.....	8
DC POWER SUPPLY.....	8
GENERAL OPERATING NOTES.....	8
PERFORMANCE CHECK SHEET.....	10

Manual Reference: T:\instructword\ave\AVE2 module, ed3.odt.
 Last modified June 16, 2006.
 Copyright © 2006 Avtech Electrosystems Ltd, All Rights Reserved.

INTRODUCTION

The AVE2 series of monocycle generators allows the generation of high-speed monocycle waveforms, with peak-to-peak amplitudes of > 4 V into 50 Ω loads. The amplitude of the output waveform is not adjustable.

The monocycle center frequency is fixed. The center frequency is equal to XXXX MHz, where the model number is AVE2-XXXX.

See the online application note, "TB13 - How Is the Center Frequency of a Monocycle Waveform Measured?" at <http://www.avtechpulse.com/appnote/techbrief13/> for information about center frequency measurements.

The AVE2 can operate at repetition rates of up to 1 MHz. The AVE2 must be triggered by an external TTL pulse (> 50 ns) applied to the "IN" connector.

The output is designed to drive 50 Ω loads. (A 50 Ω load is required for proper operation.) The output is AC-coupled.

This instrument is intended for use in research, development, test and calibration laboratories by qualified personnel.

SPECIFICATIONS

Model:	AVE2
Center frequency:	3000-5000 MHz, fixed-tuned ¹
Amplitude: (V_{pp} , 50 Ω)	≥ 4
PRF _{max} (MHz):	1.0
Spurious signals:	26 dB (WRT peak)
Propagation delay:	≤ 50 ns (Ext trig in to pulse out)
Jitter:	± 15 ps (Ext trig in to pulse out)
DC offset option ² :	Apply required DC offset (± 50 V, 250 mA max) to back-panel terminals
Trigger required:	Modules and -C ext trig mode: + 5 Volt, 50 to 500 ns (TTL)
Connectors:	In, Out: SMA. Power: solder terminals.
Power requirement:	+15 Volt, 200 mA
Dimensions: (H x W x D)	43 x 76 x 152 mm (1.7" x 3" x 6")
Chassis material:	cast aluminum, blue enamel
Temperature range:	+5°C to +40°C

1) Specify required frequency.

2) For DC offset option suffix model number with -OS. Avtech Model AVX-T bias tee can also be used to obtain DC offset.

EUROPEAN REGULATORY NOTES

EC DECLARATION OF CONFORMITY

We Avtech Electrosystems Ltd.
P.O. Box 5120, LCD Merivale
Ottawa, Ontario
Canada K2C 3H4

declare that this pulse generator meets the intent of Directive 89/336/EEC for Electromagnetic Compatibility. Compliance pertains to the following specifications as listed in the official Journal of the European Communities:

EN 50081-1 Emission

EN 50082-1 Immunity

and that this pulse generator meets the intent of the Low Voltage Directive 72/23/EEC as amended by 93/68/EEC. Compliance pertains to the following specifications as listed in the official Journal of the European Communities:

EN 61010-1:2001 Safety requirements for electrical equipment for measurement, control, and laboratory use



DIRECTIVE 2002/95/EC (RoHS)

This instrument is exempt from Directive 2002/95/EC of the European Parliament and of the Council of 27 January 2003 on the Restriction of the use of certain Hazardous Substances (RoHS) in electrical and electronic equipment. Specifically, Avtech instruments are considered "Monitoring and control instruments" (Category 9) as defined in Annex 1A of Directive 2002/96/EC. The Directive 2002/95/EC only applies to Directive 2002/96/EC categories 1-7 and 10, as stated in the "Article 2 - Scope" section of Directive 2002/95/EC.

DIRECTIVE 2002/96/EC (WEEE)

European customers who have purchased this equipment directly from Avtech will have completed a "WEEE Responsibility Agreement" form, accepting responsibility for

WEEE compliance (as mandated in Directive 2002/96/EC of the European Union and local laws) on behalf of the customer, as provided for under Article 9 of Directive 2002/96/EC.

Customers who have purchased Avtech equipment through local representatives should consult with the representative to determine who has responsibility for WEEE compliance. Normally, such responsibilities will lie with the representative, unless other arrangements (under Article 9) have been made.

Requirements for WEEE compliance may include registration of products with local governments, reporting of recycling activities to local governments, and financing of recycling activities.



BASIC TEST ARRANGEMENT

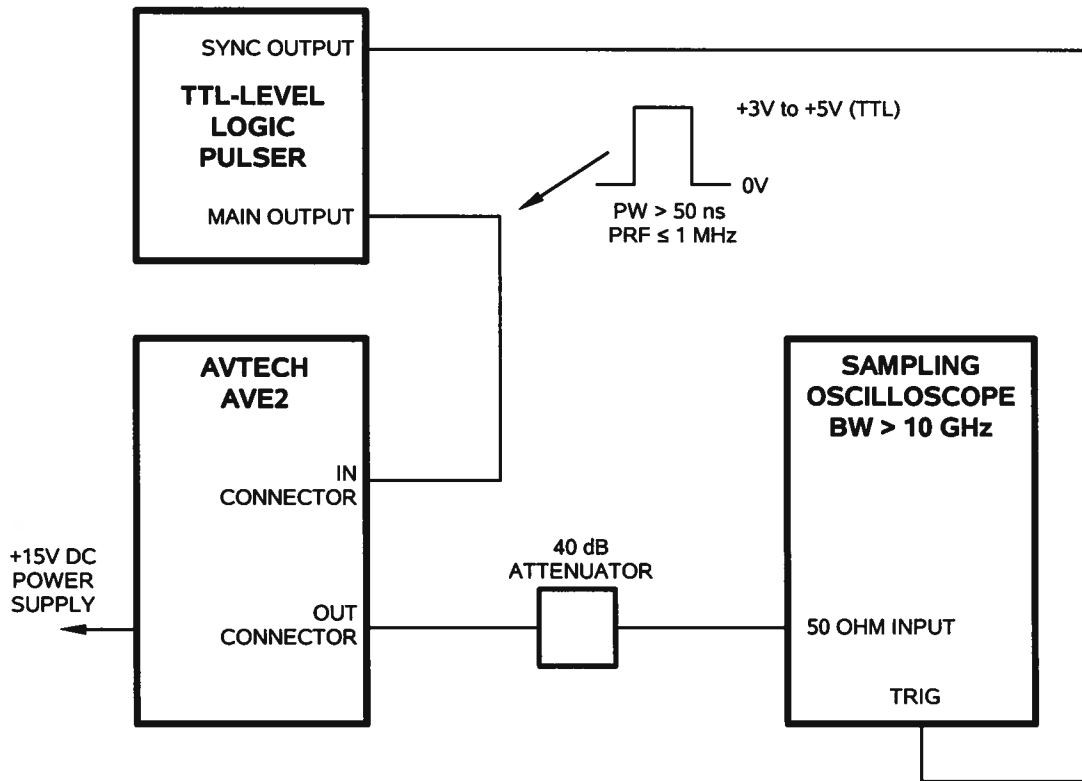

DC POWER SUPPLY

The AVE2 must be connected to a stable +15V DC power supply (as well as a ground connection).

The power supply input is protected from excessive voltages and incorrect polarities by an externally-mounted (and replaceable) 1N4746A Zener diode. This diode may be damaged by reversed polarities, or voltages exceeding 18V.

GENERAL OPERATING NOTES

- 1) The bandwidth capability of components and instruments used to display the pulse generator output signal (attenuators, cables, connectors, etc.) should exceed 10 GHz.
- 2) The use of 40 dB attenuator on the output will ensure a peak input signal to the sampling scope of much less than 1V.
- 3) To DC offset the output pulse connect a DC power supply set to required DC offset value to the terminals marked "OS". The maximum attainable DC offset voltage is

+50 Volts. (Option).

- 4) **WARNING:** The module may fail if triggered at a PRF greater than 1 MHz.
- 5) A ten-turn trimpot (labeled "T") is accessible through the top cover of the chassis. Clockwise rotation of this trimpot will increase the output amplitude by up to 50%. It may also affect the output center frequency and the spurious output levels.

June 16/06