



AVTECH ELECTROSYSTEMS LTD.

NANOSECOND WAVEFORM ELECTRONICS
SINCE 1975

P.O. BOX 265
OGDENSBURG, NY
U.S.A. 13669-0265
TEL: (315) 472-5270
FAX: (613) 226-2802

TEL: 1-800-265-6681
FAX: 1-800-561-1970

e-mail: info@avtechpulse.com
<http://www.avtechpulse.com>

P.O. BOX 5120 STN. F
OTTAWA, ONTARIO
CANADA K2C 3H4
TEL: (613) 226-5772
FAX: (613) 226-2802

INSTRUCTIONS

MODEL AVG-4C-C IMPULSE GENERATOR

S.N.:

WARRANTY

Avtech Electrosystems Ltd. warrants products of its manufacture to be free from defects in material and workmanship under conditions of normal use. If, within one year after delivery to the original owner, and after prepaid return by the original owner, this Avtech product is found to be defective, Avtech shall at its option repair or replace said defective item. This warranty does not apply to units which have been disassembled, modified or subjected to conditions exceeding the applicable specifications or ratings. This warranty is the extent of the obligation assumed by Avtech with respect to this product and no other warranty or guarantee is either expressed or implied.

TECHNICAL SUPPORT

Phone: 613-226-5772 or 1-800-265-6681

Fax: 613-226-2802 or 1-800-561-1970

E-mail: info@avtechpulse.com

World Wide Web: <http://www.avtechpulse.com>

TABLE OF CONTENTS

WARRANTY	2
TABLE OF CONTENTS	3
FIG. 1: IMPULSE GENERATOR TEST ARRANGEMENT	4
GENERAL OPERATING INSTRUCTIONS	5
FIG. 2: FRONT PANEL CONTROLSFRONT PANEL CONTROLS	7
FRONT PANEL CONTROLS	8
FIG. 3: BACK PANEL CONTROLS	10
BACK PANEL CONTROLS	11
TOP COVER REMOVAL	12
PERFORMANCE CHECK SHEET	13

FIG. 1: IMPULSE GENERATOR TEST ARRANGEMENT

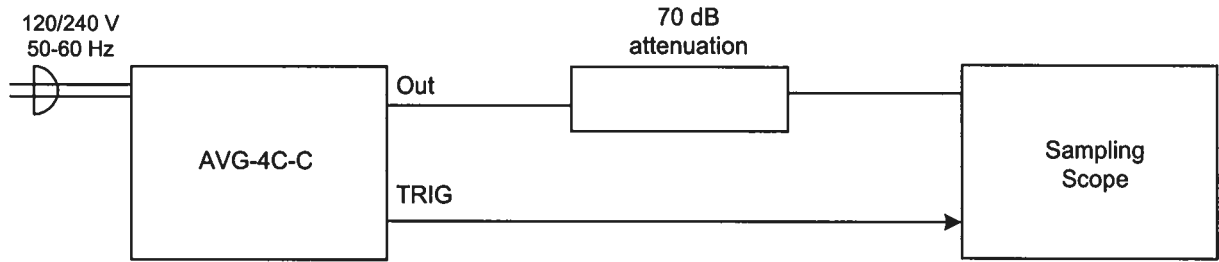

CAUTION: Exercise due caution when employing this instrument as it provides output pulses as high as 1000 Volts!!

GENERAL OPERATING INSTRUCTIONS

- 1) The bandwidth capability of components and instruments used to display the pulse generator output signal (attenuators, cables, connectors, etc.) should exceed one gigahertz.
- 2) The use of 70-dB attenuator at the sampling scope vertical input channel will insure a peak input signal to the sampling scope of less than one Volt.
CAUTION: Insure that the attenuator can withstand the exceptionally high input voltage level (1000 Volts).
- 3) The TRIG output channel provides TTL level signals.

To obtain a stable output display the PRF control on the front panel should be set mid-range while the PRF range switch may be in either range (but not in the EXT position).

The DELAY controls and the scope triggering controls are then adjusted to obtain a stable output.

- 4) The general pulse shape is controlled by the following three controls:

PWA, PWB: The main shape controls. Clockwise rotation increased the pulse width (and amplitude). Normally the two controls are set at the same value and normally are set max clockwise.

TAB: This control is adjusted to peak the output amplitude.

After changing the PRF dramatically, it may be necessary to re-adjust the three controls to re-obtain the desired output pulse shape.

- 5) The main output must see a well-defined 50-Ohm load and low loss 50-Ohm cable (eg, 80 mil or larger semi-rigid) should be used. This cable can be as long as several feet. The termination load should be of the form shown below:

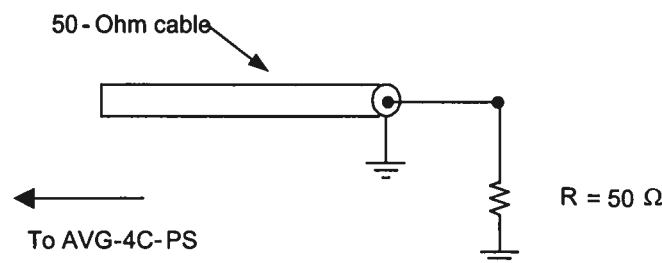

- 6) The output amplitude is controlled by the front panel one-turn amplitude control and the two position High-Low switch. With the switch in the high position, the output amplitude may be varied from 300 to 1000 volts. With the switch in the low position, the amplitude may be varied from 0 to 850 volts.
- 7) The unit may be triggered externally by placing the MODE switch in the EXT position and applying a TTKL level pulse ($PW > 50$ ns) to the TRIG connector.
- 8) The unit can be converted from 120 to 240V 50-60 Hz operation by adjusting the voltage selector card in the rear panel fused voltage selector cable connector assembly.
- 9) For additional assistance:

Tel: (613) 226-5772

Fax: (613) 226-2802

Email: info@avtechpulse.com

FIG. 2: FRONT PANEL CONTROLS

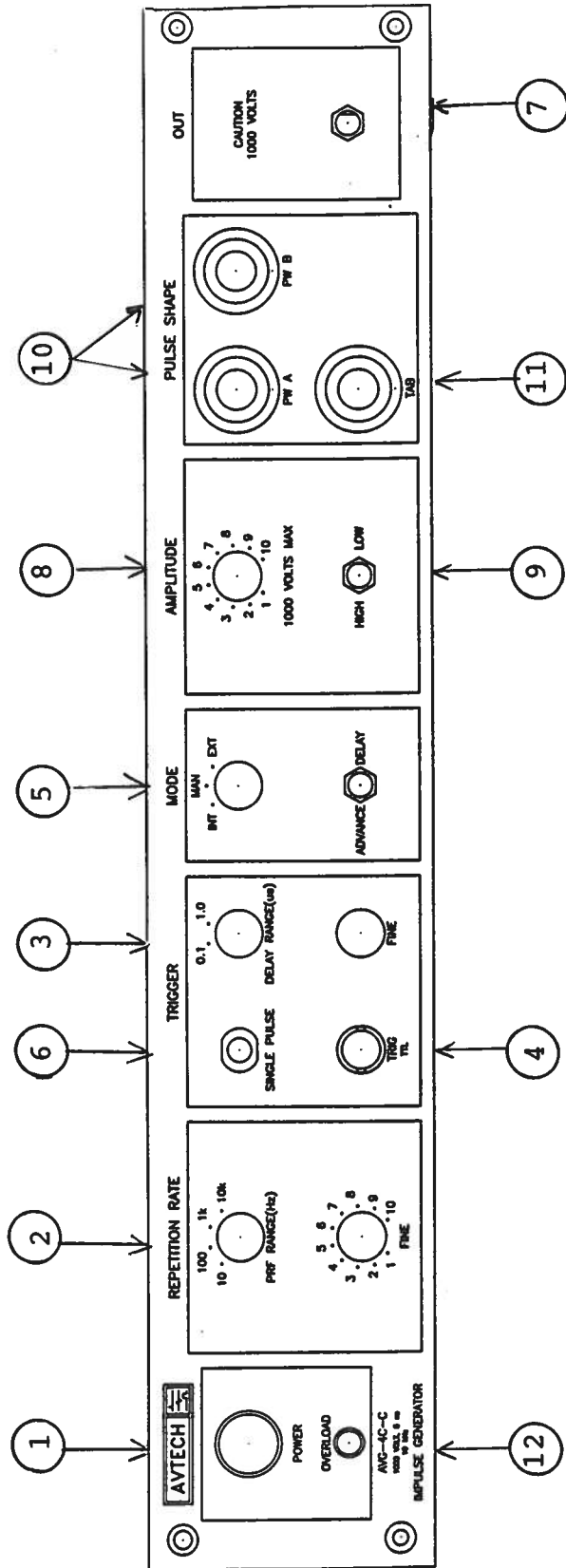

FRONT PANEL CONTROLS

- (1) ON-OFF Switch. Applies basic prime power to all stages.
- (2) PRF Control. The PRF RANGE and PRF controls determine output PRF as follows:

	PRF MIN	PRF MAX
Range 1	1 Hz	10 Hz
Range 2	10 Hz	100 kHz
Range 3	100 Hz	1 kHz
Range 4	1 kHz	10 kHz

- (3) DELAY Control. Controls the relative delay between the reference output pulse provided at the TRIG output (4) the main output (7). This delay is variable over the range of 0 to about 1.0 μ s. Delay LEADS and LAGS depending on the position of the ADVANCE-DELYA switch.
- (4) TRIG Output. This output is used to trigger the scope time base. The output is a TTL level 100 ns (approx.) pulse capable of driving a 50-Ohm load. This output precedes the output at (7) if the two-position ADVANCE-DELAY switch is in the ADVANCE position. This output follows the output at (7) if the switch is in the DELAY position. The external trigger signal is applied at this input when the MODE switch is in the EXT position.
- (5) MODE. With this switch in the INT position, the PRF of the AVG unit is controlled via an internal clock, which in turn is controlled by the PRF controls. With the switch in the EXT position, the AVG unit requires a 50 ns (or wider) TTL level pulse applied at the TRIG input in order to trigger the output stages. In addition, in this mode, the scope time base must be triggered by the external trigger source.
- (6) SINGLE PULSE. For single pulse manual operation, set the front panel MODE switch in the MAN position and push the SINGLE PULSE button.
- (7) OUT Connector. SMA connector provides output to the load ($R_L = 50$ Ohm).
- (8) AMP Control. A one-turn control and two position range switch, which vary the output pulse amplitude from 300 to 1000 volts (high) or 0 to 850 volts (low).

- (9) POLARITY. The output polarity is controlled by the two-position polarity switch.
- (10) PWA, PWB. The main shape controls. Clockwise rotation of the two ten-turn controls increases the pulse width (and amplitude to a lesser extent). Normally the two controls are set at the same value and normally are set fully clockwise.
- (11) TAB. This ten-turn control is adjusted to peak the output amplitude (at which point the output pulse width is minimized).
- (12) OVERLOAD INDICATOR. AVG-4C units with a serial number higher than 5600 are protected by an automatic overload protective circuit, which controls the front panel overload light. If the unit is overloaded (by operating at an exceedingly high duty cycle) the protective circuit will turn the output of the instrument OFF and turn the indicator light ON. The light will stay ON (i.e. output OFF) for about 5 seconds after which the instrument will attempt to turn ON (i.e. light OFF) for about 1 second. If the overload condition persists, the instrument will turn off again (i.e. light ON) for another 5 seconds. If the overload condition has been removed, the instrument will turn on and resume normal operation. Overload conditions may be removed by reducing the PRF.

Note that the overload light may illuminate when the prime power is first applied. The light will extinguish after a few seconds and the instrument will then function normally.

FIG. 3: BACK PANEL CONTROLS

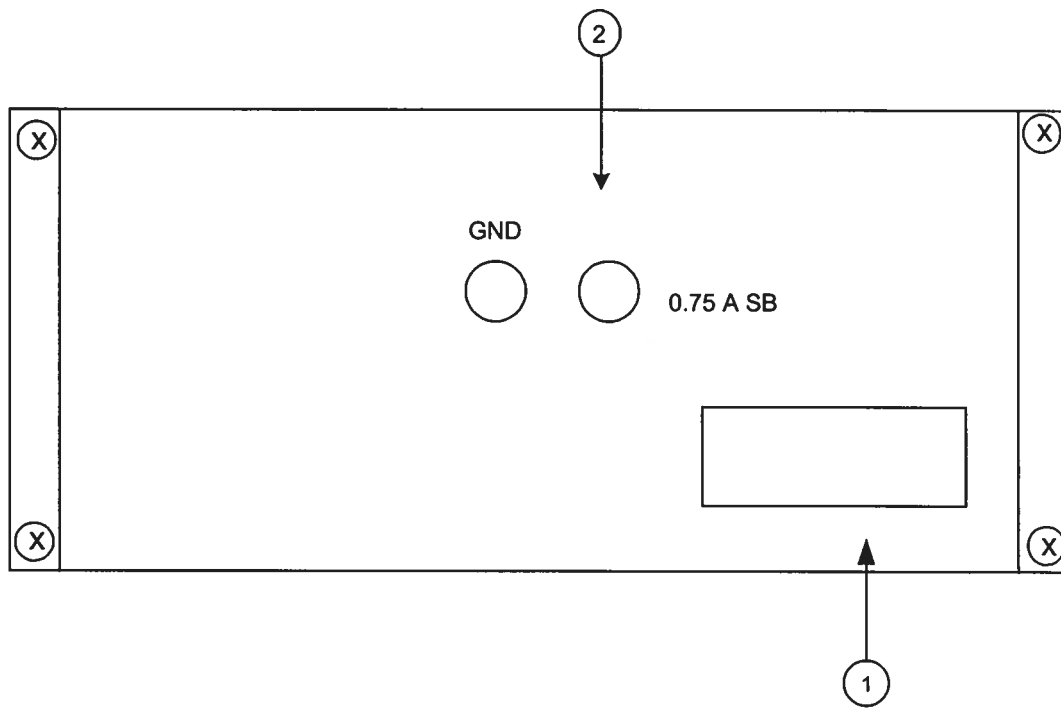

BACK PANEL CONTROLS

- (1) FUSED CONNECTOR, VOLTAGE SELECTOR. The detachable power cord is connected at this point. In addition, the removable cord is adjusted to select the desired input operating voltage. The unit also contains the main power fuse. For AC line voltages of 110-120V, the power selector card should be installed so that the "120" marking is visible from the rear of the instrument.

For AC line voltages of 220-240V, the power selector card should be installed so that the "240" marking is visible from the rear of the instrument.

If it is not set for the proper voltage, remove the fuse and then grasp the card with a pair of pliers and remove it. Rotate horizontally through 180 degrees. Reinstall the card and the correct fuse.

In the 120V setting, a 1.0A slow blow fuse is required. In the 240V setting, a 0.5A slow blow fuse is required.

- (2) 0.75A SB: This fuse limits the DC current supplied to the output stage.

TOP COVER REMOVAL

The interior of the instrument may be accessed by removing the four Philips screws on the top panel. With the four screws removed, the top cover may be slid back (and off). **CAUTION:** DC potentials as high as 425 Volts are employed in the chassis interior and so it is recommended that the unit be returned to AVTECH for any required servicing.

The -R5 Rack Mount Kit may be installed after first removing the one Philips screw on the side panel adjacent to the front handle.

Oct 30, 2002

