



**AVTECH ELECTROSYSTEMS LTD.**

NANOSECOND WAVEFORM ELECTRONICS  
SINCE 1975

P.O. BOX 265  
OGDENSBURG, NY  
U.S.A. 13669-0265  
TEL: (315) 472-5270  
FAX: (613) 226-2802

TEL: 1-800-265-6681  
FAX: 1-800-561-1970

e-mail: [info@avtechpulse.com](mailto:info@avtechpulse.com)  
<http://www.avtechpulse.com/>

BOX 5120, LCD MERIVALE  
OTTAWA, ONTARIO  
CANADA K2C 3H4  
TEL: (613) 226-5772  
FAX: (613) 226-2802

## INSTRUCTIONS

MODEL AVG-4C-C-P-M-WSC

150 to 1000 VOLTS, 10 kHz

HIGH SPEED IMPULSE GENERATOR

WITH 8 ns PULSE WIDTH

SERIAL NUMBER: \_\_\_\_\_

### WARRANTY

Avtech Electrosystems Ltd. warrants products of its manufacture to be free from defects in material and workmanship under conditions of normal use. If, within one year after delivery to the original owner, and after prepaid return by the original owner, this Avtech product is found to be defective, Avtech shall at its option repair or replace said defective item. This warranty does not apply to units which have been disassembled, modified or subjected to conditions exceeding the applicable specifications or ratings. This warranty is the extent of the obligation assumed by Avtech with respect to this product and no other warranty or guarantee is either expressed or implied.

### TECHNICAL SUPPORT

Phone: 613-226-5772 or 1-800-265-6681

Fax: 613-226-2802 or 1-800-561-1970

E-mail: [info@avtechpulse.com](mailto:info@avtechpulse.com)

World Wide Web: <http://www.avtechpulse.com>

## TABLE OF CONTENTS

<b>WARRANTY.....</b>	<b>2</b>
<b>TECHNICAL SUPPORT.....</b>	<b>2</b>
<b>TABLE OF CONTENTS.....</b>	<b>3</b>
<b>INTRODUCTION.....</b>	<b>4</b>
<b>-WSC OPTION.....</b>	<b>4</b>
<b>SPECIFICATIONS.....</b>	<b>5</b>
<b>HIGH-VOLTAGE PRECAUTIONS.....</b>	<b>6</b>
<b>EC DECLARATION OF CONFORMITY.....</b>	<b>7</b>
<b>INSTALLATION.....</b>	<b>8</b>
<b>VISUAL CHECK.....</b>	<b>8</b>
<b>POWER RATINGS.....</b>	<b>8</b>
<b>CONNECTION TO THE POWER SUPPLY.....</b>	<b>8</b>
<b>ENVIRONMENTAL CONDITIONS.....</b>	<b>8</b>
<b>FUSES.....</b>	<b>9</b>
<b>AC FUSE REPLACEMENT.....</b>	<b>9</b>
<b>DC FUSE REPLACEMENT.....</b>	<b>10</b>
<b>FUSE RATINGS.....</b>	<b>10</b>
<b>FRONT PANEL CONTROLS.....</b>	<b>11</b>
<b>REAR PANEL CONTROLS.....</b>	<b>13</b>
<b>GENERAL INFORMATION.....</b>	<b>14</b>
<b>BASIC TEST ARRANGEMENT.....</b>	<b>14</b>
<b>BASIC PULSE CONTROL.....</b>	<b>14</b>
<b>MECHANICAL INFORMATION.....</b>	<b>16</b>
<b>TOP COVER REMOVAL.....</b>	<b>16</b>
<b>ELECTROMAGNETIC INTERFERENCE.....</b>	<b>16</b>
<b>MAINTENANCE.....</b>	<b>17</b>
<b>REGULAR MAINTENANCE.....</b>	<b>17</b>
<b>CLEANING.....</b>	<b>17</b>
<b>PERFORMANCE CHECK SHEET.....</b>	<b>18</b>

## INTRODUCTION

The AVG-4C-C-P-M-WSC is a high performance instrument capable of generating up to 1000V into 50 $\Omega$  loads at repetition rates up to 10 kHz. The pulse width is nominally 8 ns, but it can be adjusted over a narrow range.

Instruments with the "-P" model suffix can generate +150V to +1000V, whereas instruments with the "-N" model suffix can generate -150V to -1000V. Instruments with the "-PN" suffix can generate both polarities.

The output is designed to drive 50 $\Omega$  loads. (A 50 $\Omega$  load is required for proper operation.) The output is AC-coupled.

This instrument is intended for use in research and development laboratories.

### -WSC OPTION

The -WSC option adds a rear-panel SHV input connector, to which an externally-generated 0 to 1.5 kV DC voltage may be connected. This offset is added to the output pulse. The DC load impedance must be greater than 1 Megohm. (Note that the high-frequency load impedance must be 50 Ohms. This can be achieved by shunting the input to your micro-channel plate using a series combination of a 50 Ohm resistor and a high-voltage capacitor.) The monitor output (-M option) does not include the DC component; it only includes the pulse component.

*CAUTION: SEE -WSC OPTION NOTE  
ON PERFORMANCE CHECK  
SHEET! (PAGE 13).*

## SPECIFICATIONS

Model:	AVG-4C-C <sup>1</sup>
Amplitude <sup>2</sup> :	150-1000 Volts (50 Ohm load)
Pulse width, at 20% rise time:	≤ 8 ns
Rise time:	≤ 2.5 ns
Fall time:	≤ 4 ns
PRF:	0 to 10 kHz
Polarity <sup>3</sup> :	Positive or negative or both (specify)
Propagation delay:	≤ 50 ns (Ext trig in to pulse out)
Jitter:	± 100 ps (Ext trig in to pulse out)
DC offset:	Optional <sup>4</sup> : Apply required DC offset (± 50 Volts, 250 mA max) to back-panel solder terminals
Trigger required:	External trigger mode: +5 Volts, 50 to 500 ns (TTL)
Sync delay:	Sync out to pulse out: Variable 0 to 200 ns
Sync out:	+ 3 Volts, 200 ns, will drive 50 Ohm loads
Monitor output:	Optional <sup>5</sup> : Provides a 20 dB attenuated coincident replica of main output
Connectors:	Out: N, Trig: BNC
Dimensions (H x W x D):	100 mm x 430 mm x 375 mm (3.9" x 17" x 14.8")
Power:	100 - 240 Volts, 50 - 60 Hz
Temperature range:	+5°C to +40°C

- 1) -C suffix indicates stand-alone lab instrument with internal clock and line powering. No suffix indicates miniature module requiring DC power and external trigger. (See page 112 for additional details of the four basic instrument formats).
- 2) For electronic control (0 to + 10 V) of amplitude, suffix the model number with -EA. Electronic control units also include standard front-panel one-turn controls.
- 3) Indicate desired polarity by suffixing model number with -P or -N (i.e. positive or negative) or -PN for the dual polarity option. (-PN available only on -B and -C units). AVX-1 transformer may be used to invert polarity.
- 4) For DC offset option suffix model number with -OS.
- 5) For monitor option add suffix -M.

## HIGH-VOLTAGE PRECAUTIONS

 **CAUTION:** This instrument generates output pulse amplitudes as high as 1000 Volts, so extreme caution must be employed when using this instrument. The instrument should only be used by individuals who are thoroughly skilled in high voltage laboratory techniques. The following precautions should always be observed:

1. Keep exposed high-voltage wiring to an absolute minimum.
2. Wherever possible, use shielded connectors and cabling.
3. Connect and disconnect loads and cables only when the amplifier is turned off.
4. Consider using attenuators to reduce observed signals to lower and safer voltages.
5. Keep in mind that all cables, connectors, oscilloscope probes, and loads must have an appropriate voltage rating.

Do not attempt any repairs on the instrument, beyond the fuse replacement procedures described in this manual. Contact Avtech technical support (see page 2 for contact information) if the instrument requires servicing.

EC DECLARATION OF CONFORMITY

We

Avtech Electrosystems Ltd.  
P.O. Box 5120, LCD Merivale  
Ottawa, Ontario  
Canada K2C 3H4

declare that this pulse generator meets the intent of Directive 89/336/EEC for Electromagnetic Compatibility. Compliance pertains to the following specifications as listed in the official Journal of the European Communities:

EN 50081-1 Emission

EN 50082-1 Immunity

and that this pulse generator meets the intent of the Low Voltage Directive 72/23/EEC as amended by 93/68/EEC. Compliance pertains to the following specifications as listed in the official Journal of the European Communities:

EN 61010-1:2001 Safety requirements for electrical equipment for measurement, control, and laboratory use



## INSTALLATION

### VISUAL CHECK

After unpacking the instrument, examine to ensure that it has not been damaged in shipment. Visually inspect all connectors, knobs, liquid crystal displays (LCDs), and the handles. Confirm that a power cord, a GPIB cable, and two instrumentation manuals (this manual and the "Programming Manual for -B Instruments") are with the instrument. If the instrument has been damaged, file a claim immediately with the company that transported the instrument.

### POWER RATINGS

This instrument is intended to operate from 100 - 240 V, 50 - 60 Hz.

The maximum power consumption is 57 Watts. Please see the "FUSES" section for information about the appropriate AC and DC fuses.

This instrument is an "Installation Category II" instrument, intended for operation from a normal single-phase supply.

### CONNECTION TO THE POWER SUPPLY

An IEC-320 three-pronged recessed male socket is provided on the back panel for AC power connection to the instrument. One end of the detachable power cord that is supplied with the instrument plugs into this socket. The other end of the detachable power cord plugs into the local mains supply. Use only the cable supplied with the instrument. The mains supply must be earthed, and the cable used to connect the instrument to the mains supply must provide an earth connection. (The supplied cable does this.)

### ENVIRONMENTAL CONDITIONS

This instrument is intended for use under the following conditions:

- a) indoor use;
- b) altitude up to 2 000 m;
- c) temperature 5 °C to 40 °C;
- d) maximum relative humidity 80 % for temperatures up to 31 °C decreasing linearly to 50 % relative humidity at 40 °C;
- e) Mains supply voltage fluctuations up to  $\pm 10$  % of the nominal voltage;
- f) no pollution or only dry, non-conductive pollution.



## FUSES

This instrument contains four fuses. All are accessible from the rear-panel. Two protect the AC prime power input, and two protect the internal DC power supplies. The locations of the fuses on the rear panel are shown in the figure below:

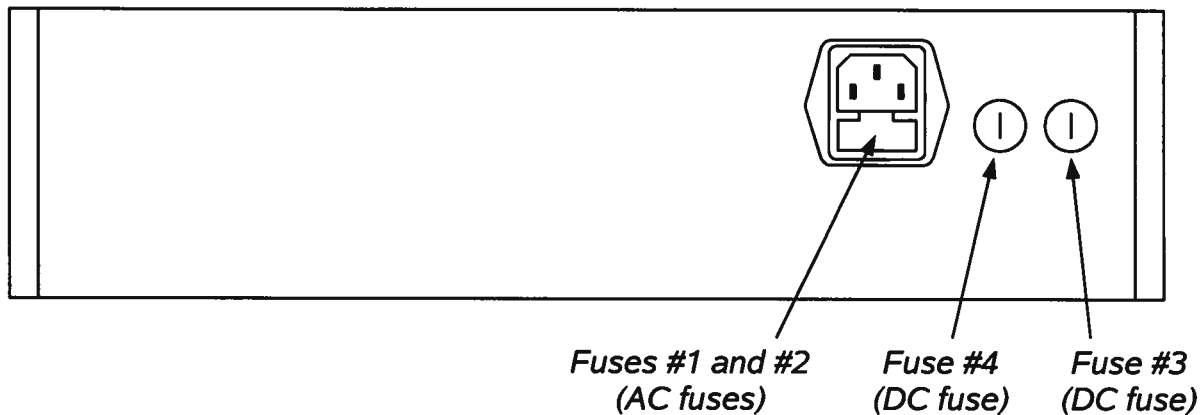

### AC FUSE REPLACEMENT

To physically access the AC fuses, the power cord must be detached from the rear panel of the instrument. The fuse drawer may then be extracted using a small flat-head screwdriver, as shown below:

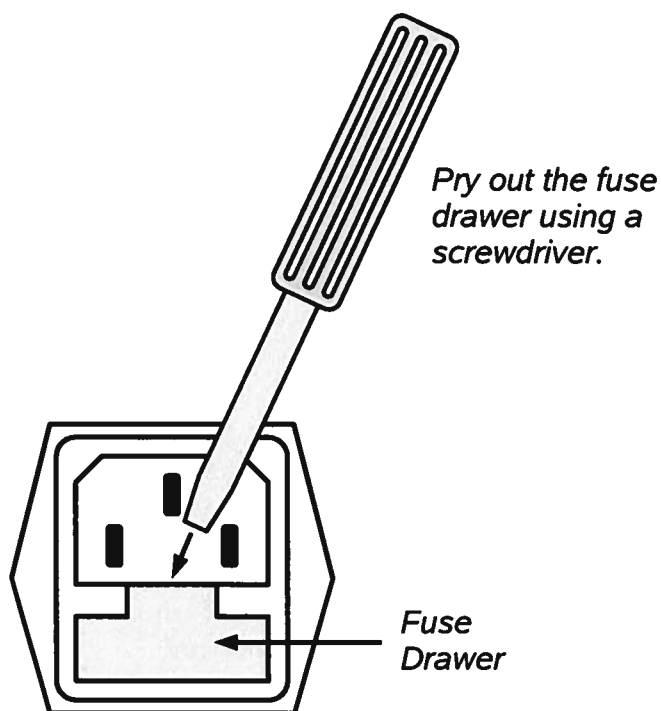

## DC FUSE REPLACEMENT

The DC fuses may be replaced by inserting the tip of a flat-head screwdriver into the fuse holder slot, and rotating the slot counter-clockwise. The fuse and its carrier will then pop out.

## FUSE RATINGS

The following table lists the required fuses:

Fuses	Nominal Mains Voltage	Rating	Case Size	Manufacturer's Part Number (Wickmann)	Distributor's Part Number (Digi-Key)
#1, #2 (AC)	100-240V	0.5A, 250V, Time-Delay	5×20 mm	1950500000	WK5041-ND
#3 (DC)	N/A	1.6A, 250V, Time-Delay	5×20 mm	1951160000	WK5053-ND
#4 (DC)	N/A	0.8A, 250V, Time-Delay	5×20 mm	1950800000	WK5046-ND

The fuse manufacturer is Wickmann (<http://www.wickmann.com/>).

Replacement fuses may be easily obtained from Digi-Key (<http://www.digikey.com/>) and other distributors.

## FRONT PANEL CONTROLS

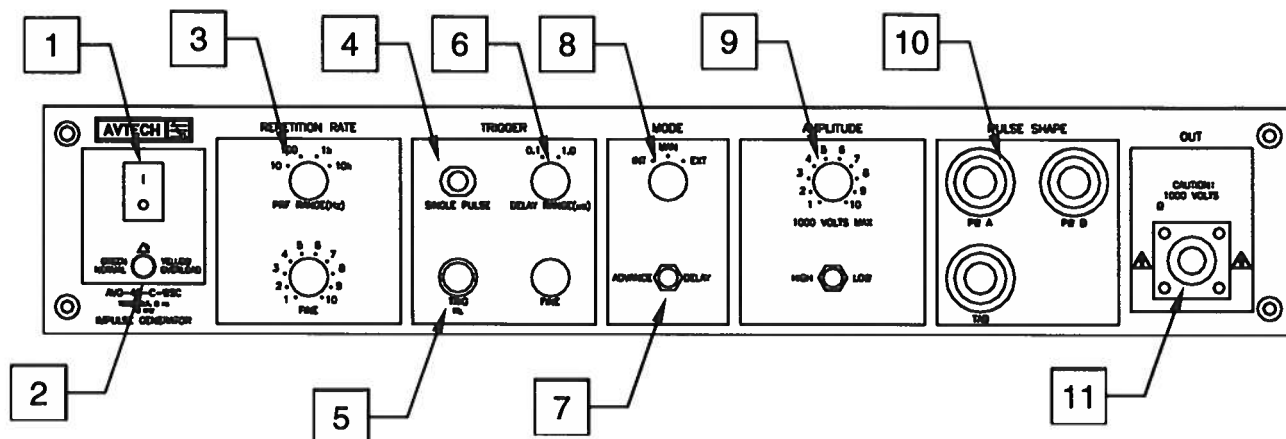

1. **POWER Switch**. This is the main power switch. When turning the instrument on, there may be a delay of several seconds before the instrument appears to respond.
  2. **OVERLOAD Indicator**. When the instrument is powered, this indicator is normally green, indicating normal operation. If this indicator is yellow, an internal automatic overload protection circuit has been tripped. If the unit is overloaded (by operating at an exceedingly high duty cycle or by operating into a very low impedance), the protective circuit will disable the output of the instrument and turn the indicator light yellow. The light will stay yellow (i.e. output disabled) for about 5 seconds after which the instrument will attempt to re-enable the output (i.e. light green) for about 1 second. If the overload condition persists, the output will be disabled again (i.e. light yellow) for another 5 seconds. If the overload condition has been removed, the instrument will resume normal operation.
- This overload indicator may flash yellow briefly at start-up. This is not a cause for concern.
3. **PRF Range Switch and Vernier**. This switch sets the pulse repetition frequency (PRF) range of the internal oscillator. The marked value of each position is the upper limit of the range, approximately. The vernier dial directly below the switch varies the PRF within the set range.
  4. **SINGLE PULSE Push Button**. The "SINGLE PULSE" push button will trigger the instrument manually for one cycle of output, when the "MODE" switch is in the "MAN" position. Otherwise, the push button has no effect.
  5. **TRIG Connector**. When the "MODE" switch is in the "EXT" position, this connector is an input. The external trigger (50 ns or wider, TTL levels) is applied to this connector.

When operating in the "INT" mode, this connector is an output. A SYNC output is generated on this connector, to synchronize oscilloscopes or other measurement

systems.

6. Delay Range Switch and Vernier. This switch and one-turn dial sets the delay between the main output and the TRIG output. The marked value of each switch position is the upper limit of the range, approximately. The vernier dial directly below the switch varies the delay within the set range.
7. ADVANCE/DELAY Switch. With this switch in the DELAY position, the leading edge of the output pulse precedes the leading edge of the TRIG output. When in the ADVANCE position, the leading edge of the TRIG output precedes the leading edge of the main output.
8. MODE Switch. In the "INT" position the instrument is internally triggered and the TRIG connector provides a SYNC output which allows one to trigger other instruments, such as oscilloscopes.

In the "MAN" position a single pulse can be generated by pressing the "SINGLE PULSE" push button. The TRIG connector is not used in this mode.

In the "EXT" position the instrument is triggered by a TTL-level pulse on the TRIG connector. The output parameters (pulse width, delay, and amplitude) are determined by the front panel settings.

9. AMPLITUDE Controls. The output amplitude is controlled by this one-turn dial and two-position High/Low switch. With the switch in the high position, the output amplitude may be varied from 300 to 1000 Volts, approximately. With the switch in the low position, the amplitude may be varied from 0 to 850 Volts, approximately.
10. PUSH SHAPE Controls. The AVG-4C-C-P-M-WSC output stage consists of two separate pulse generator circuits, whose outputs are combined to generate the main output impulse. The PW A and PW B dials control the pulse widths of the two components, and the TAB dial controls the delay between the two components. Normally, PW A and PW B are set fully clockwise, and TAB is set mid-range. These three controls should be adjusted to obtain the optimal waveshape (i.e., pulse width and amplitude) for your application.

It may be necessary to re-adjust the controls if the pulse repetition frequency is changed.

11. OUT CONNECTOR. This N connector provides the main output signal, into load impedances of 50 Ohms.

 **Caution:** Voltages as high as  $\pm 2500\text{V}$  may be present on the center conductor of this output connector. Avoid touching this conductor. Connect to this connector using standard coaxial cable, to ensure that the center conductor is not exposed.

### REAR PANEL CONTROLS

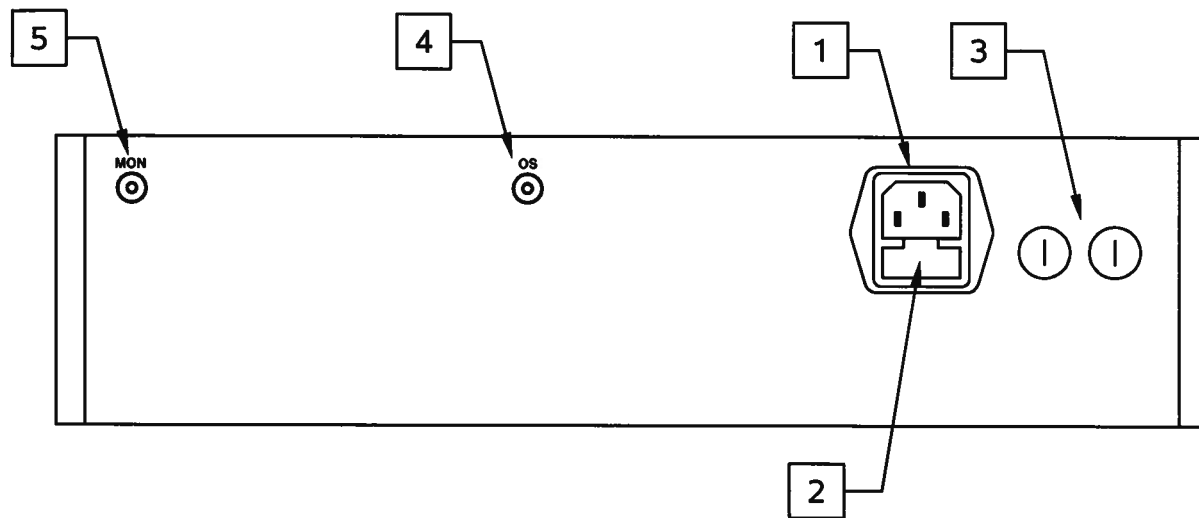

1. **AC POWER INPUT.** An IEC-320 C14 three-pronged recessed male socket is provided on the back panel for AC power connection to the instrument. One end of the detachable power cord that is supplied with the instrument plugs into this socket.
2. **AC FUSE DRAWER.** The two fuses that protect the AC input are located in this drawer. Please see the "FUSES" section of this manual for more information.
3. **DC FUSES.** These two fuses protect the internal DC power supplies. Please see the "FUSES" sections of this manual for more information.
4. **OS INPUT CONNECTOR.** The -WSC option adds this rear-panel SHV input connector, to which an externally-generated 0 to 1.5 kV DC voltage may be connected. This offset is added to the output pulse. The DC load impedance must be greater than 1 Megohm. (Note that the high-frequency load impedance must be 50 Ohms. This can be achieved by shunting the input to your micro-channel plate using a series combination of a 50 Ohm resistor and a high-voltage capacitor.) The monitor output (-M option) does not include the DC component; it only includes the pulse component.
5. **M Connector.** (Optional feature. Present on "-M" units only.) The monitor output provides an attenuated replica (20 dB down) of the voltage on the main output. The monitor output is designed to operate into a 50 Ohm load.

## GENERAL INFORMATION

### BASIC TEST ARRANGEMENT

The AVG-4C-C-P-M-WSC should be tested with a sampling oscilloscope with a bandwidth of at least 1 GHz to properly observe the high-speed waveform. A typical test arrangement is shown below:

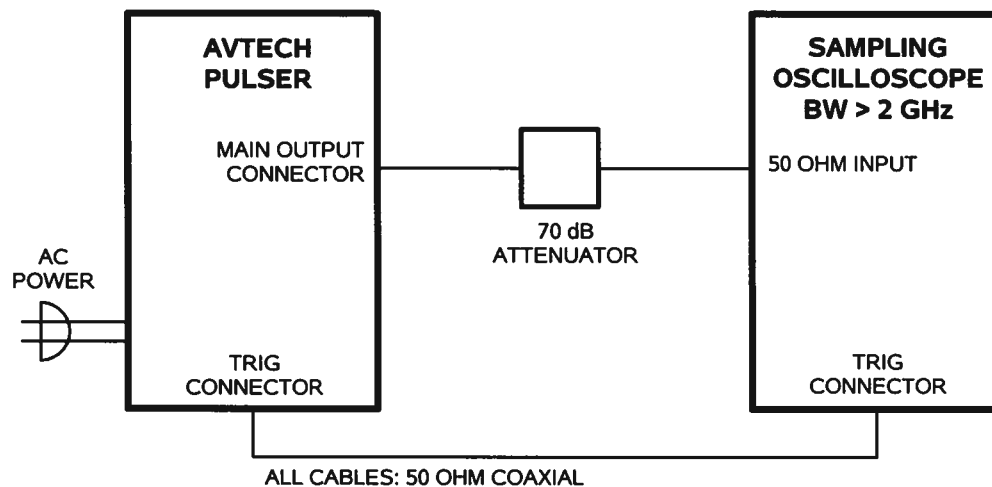

⚠ The attenuators are required to prevent damage to the sampling oscilloscope. A 70 dB attenuator with an unusually high voltage rating should be used on the main output.

⚠ Do not use the above arrangement if a DC offset is applied to the rear-panel offset input. The DC component requires a high impedance load – this can be achieved by adding a high-voltage DC blocking capacitor in series with the output of the pulser.

### BASIC PULSE CONTROL

This instrument can be triggered by its own internal clock or by an external TTL trigger signal. When triggered internally, two mainframe output channels respond to the trigger: OUT and SYNC.

- OUT. This is the main output. The maximum output voltage is 450V.
- TRIG. The TRIG pulse is a fixed-width TTL-level reference pulse used to trigger oscilloscopes or other measurement systems.

When the ADVANCE/DELAY switch is set to “ADVANCE”, the TRIG output precedes the main output. These pulses are illustrated below:

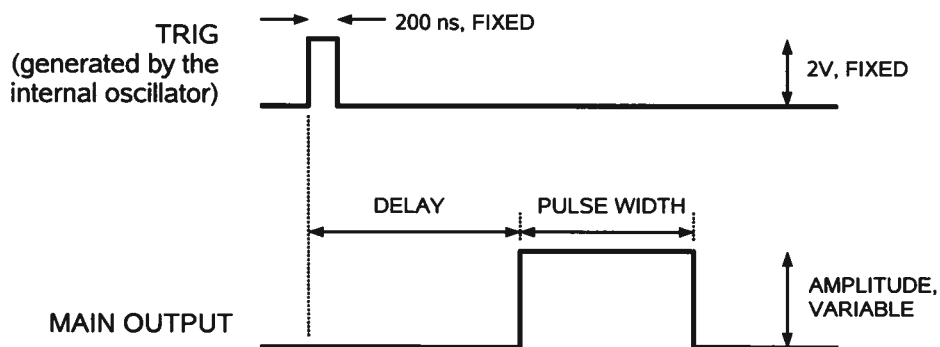
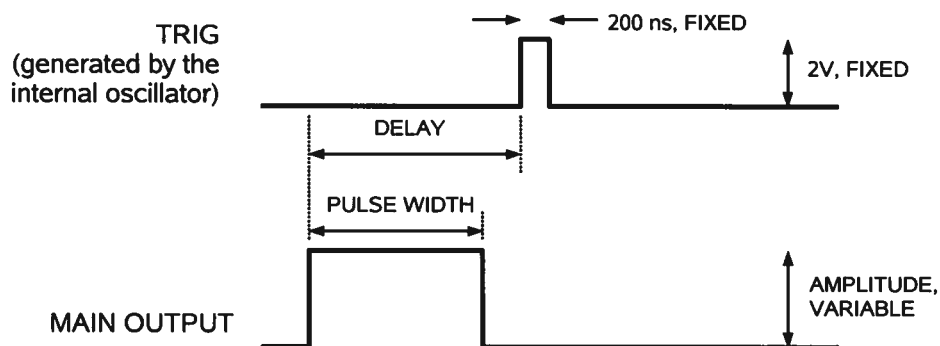
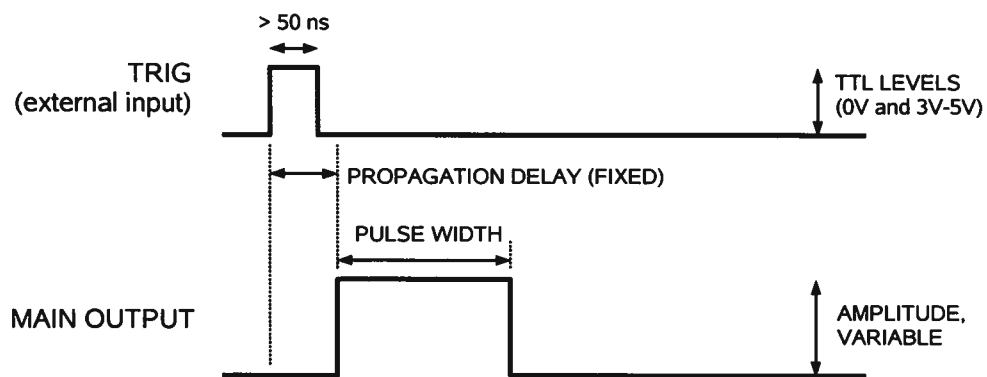

Figure A

When the ADVANCE/DELAY switch is set to "DELAY", the TRIG output occurs after the main output. This illustrated below:



When triggered externally, the TRIG connector acts as an input. The delay controls do not function in this mode. This illustrated below:



## MECHANICAL INFORMATION

### TOP COVER REMOVAL

If necessary, the interior of the instrument may be accessed by removing the four Phillips screws on the top panel. With the four screws removed, the top cover may be slid back (and off).

Always disconnect the power cord before opening the instrument.

There are no user-adjustable internal circuits. For repairs other than fuse replacement, please contact Avtech ([info@avtechpulse.com](mailto:info@avtechpulse.com)) to arrange for the instrument to be returned to the factory for repair.

 **Caution:** High voltages are present inside the instrument during normal operation. Do not operate the instrument with the cover removed.

### ELECTROMAGNETIC INTERFERENCE

To prevent electromagnetic interference with other equipment, all used outputs should be connected to shielded 50 $\Omega$  loads using shielded 50 $\Omega$  coaxial cables. Unused outputs should be terminated with shielded 50 $\Omega$  coaxial terminators or with shielded coaxial dust caps, to prevent unintentional electromagnetic radiation. All cords and cables should be less than 3m in length.



## MAINTENANCE

### REGULAR MAINTENANCE

This instrument does not require any regular maintenance.

### CLEANING

If desired, the interior of the instrument may be cleaned using compressed air to dislodge any accumulated dust. (See the "TOP COVER REMOVAL" section for instructions on accessing the interior.) No other cleaning is recommended.

Apr 22/04