



# AVTECH ELECTROSYSTEMS LTD.

NANOSECOND WAVEFORM ELECTRONICS  
SINCE 1975

□ P.O. BOX 265  
OGDENSBURG, NY  
U.S.A. 13669-0265  
TEL: (315) 472-5270  
FAX: (613) 226-2802

TEL: 1-800-265-6681  
FAX: 1-800-561-1970

e-mail: [info@avtechpulse.com](mailto:info@avtechpulse.com)  
<http://www.avtechpulse.com>

□ P.O. BOX 5120 STN. F  
OTTAWA, ONTARIO  
CANADA K2C 3H4  
TEL: (613) 226-5772  
FAX: (613) 226-2802

## INSTRUCTIONS

### MODEL AVH-S-1-C-KMP1 IMPULSE GENERATOR

S.N.:

### WARRANTY

Avtech Electrosystems Ltd. warrants products of its manufacture to be free from defects in material and workmanship under conditions of normal use. If, within one year after delivery to the original owner, and after prepaid return by the original owner, this Avtech product is found to be defective, Avtech shall at its option repair or replace said defective item. This warranty does not apply to units which have been disassembled, modified or subjected to conditions exceeding the applicable specifications or ratings. This warranty is the extent of the obligation assumed by Avtech with respect to this product and no other warranty or guarantee is either expressed or implied.

### TECHNICAL SUPPORT

Phone: 613-226-5772 or 1-800-265-6681

Fax: 613-226-2802 or 1-800-561-1970

E-mail: [info@avtechpulse.com](mailto:info@avtechpulse.com)

World Wide Web: <http://www.avtechpulse.com>

## TABLE OF CONTENTS

<u>WARRANTY</u> .....	2
<u>Fig. 1: IMPULSE GENERATOR TEST ARRANGEMENT</u> .....	4
<u>OPERATING INSTRUCTIONS</u> .....	5
<u>Fig. 2: FRONT PANEL CONTROLS</u> .....	6
<u>FRONT PANEL CONTROLS</u> .....	7
<u>Fig. 3: BACK PANEL CONTROLS</u> .....	8
<u>BACK PANEL CONTROLS</u> .....	9
<u>TOP COVER REMOVAL</u> .....	9
<u>POWER SUPPLY AND FUSE REPLACEMENT</u> .....	10
<u>PERFORMANCE CHECK SHEET</u> .....	12

Fig. 1: IMPULSE GENERATOR TEST ARRANGEMENT

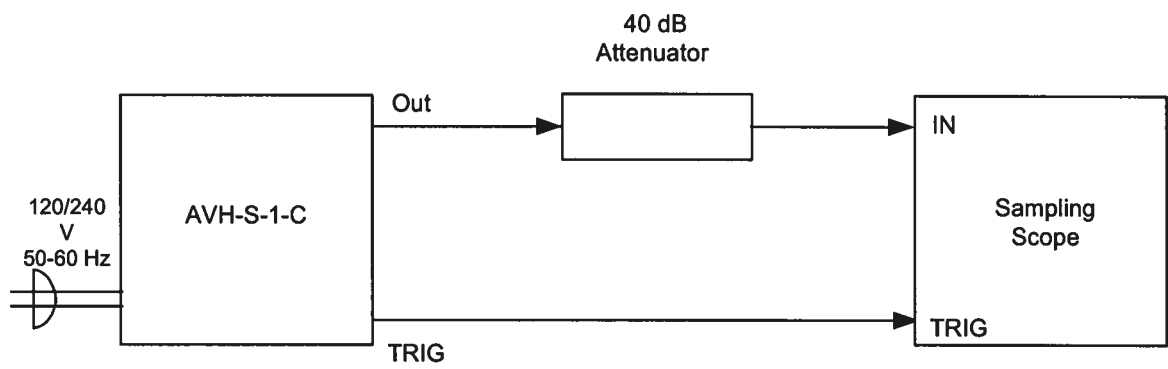

## OPERATING INSTRUCTIONS

- 1) The bandwidth capability of components and instruments used to display the pulse generator output signal (attenuators, cables, connectors, etc.) should exceed ten gigahertz.
- 2) The use of 40-dB attenuator at the sampling scope vertical input channel will insure a peak input signal to the sampling scope of less than one Volt.
- 3) The TRIG output channel provides a +3 Volt 20 ns wide pulse to fifty Ohms<sup>1</sup>. The sampling scope should be set to trigger on the positive edge of the TRIG pulse.
- 4) To obtain a stable output display the PRF controls on the front panel should be set mid-range while the PRF range switch may be in any range (except EXT). The front panel DELAY controls and the scope triggering controls are then adjusted to obtain a stable output. The scope may then be used to set the desired PRF by rotating the PRF control and by means of the PRF range switch.
- 5) The output pulse amplitude is controlled by means of the front panel one-turn "AMP" control. Some reduction in the pulse width may occur as the output amplitude is reduced. It may be necessary to employ external attenuator pads for some demanding applications.
- 6) An external clock may be used to control the output PRF of the AVH unit by setting the front panel PRF range switch in the EXT position and applying a 50 ns (or wider) TTL level pulse to the TRIG BNC connector input.
- 7) The AVH unit can be converted from 120 to 240V 50-60 Hz operation by adjusting the voltage selector card in the rear panel fused voltage selector-cable connector assembly.
- 8) For additional assistance:

Tel: 613-226-5772  
Fax: 613-226-2802  
Email: [info@avtechpulse.com](mailto:info@avtechpulse.com)

---

<sup>1</sup> The -KMP1 suffix provides for a 20 ns pulse width in place of the standard 200 ns.

Fig. 2: FRONT PANEL CONTROLS

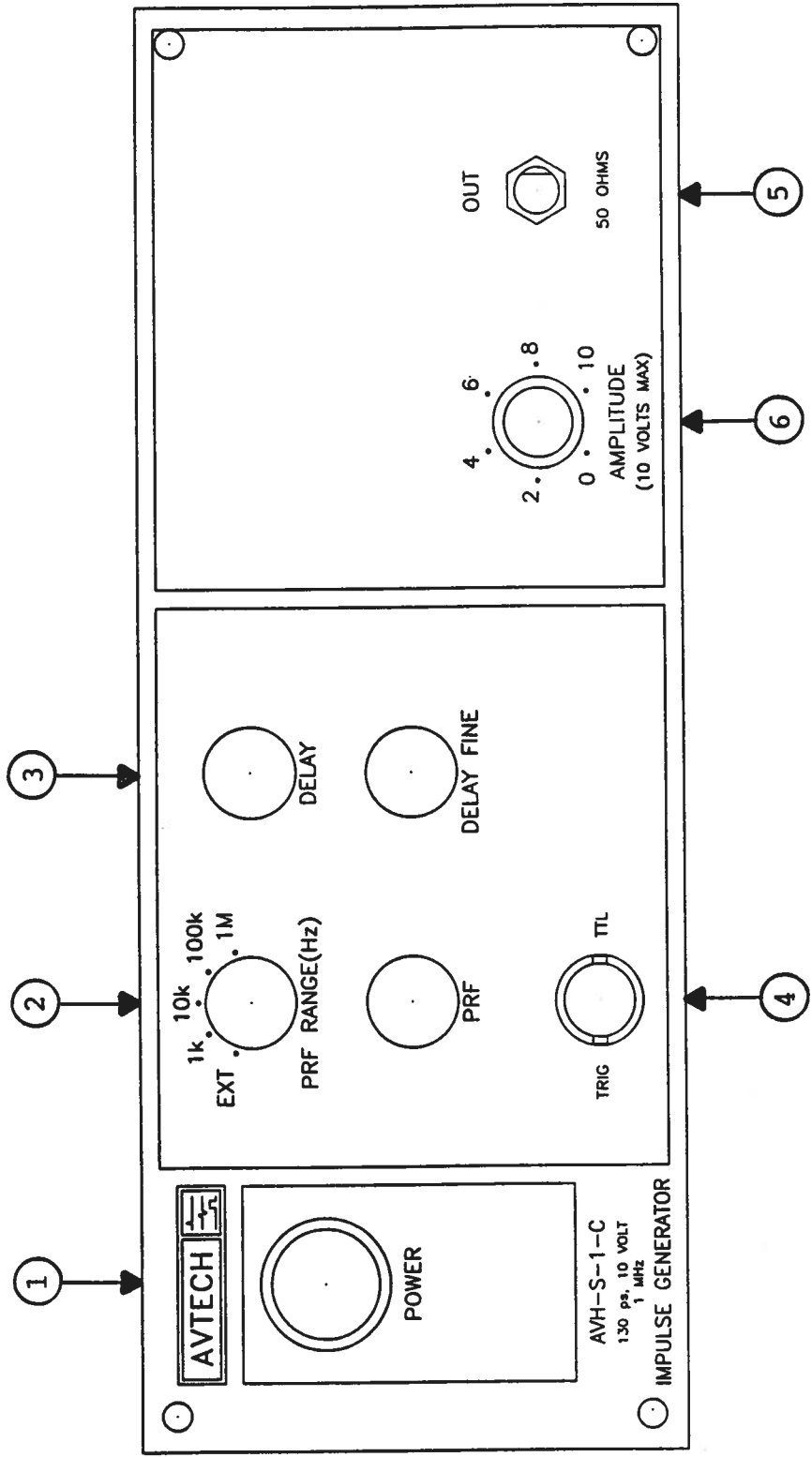

## FRONT PANEL CONTROLS

- (1) ON-OFF Switch. Applies basic prime power to all stages.
- (2) PRF Control. With this range switch in the 1K, 10K, 100K or 1M positions, the PRF of the AVH unit is controlled via an internal clock, which in turn is controlled by the PRF controls. With the range switch in the EXT position, the AVH unit requires a 50 ns (or wider) TTL level pulse applied at the TRIG input in order to trigger the output stages.
- (3) DELAY Control. Controls the relative delay between the reference output pulse provided at the TRIG output (4) and the main output (5). This delay is variable over the range of 0 to about 150 ns.
- (4) TRIG Output. When triggered internally, this output precedes the main output (5) and is used to trigger the scope time base. The output is a +3 Volt 20 ns (approx) pulse capable of driving a 50-Ohm load<sup>2</sup>. Set the scope to trigger on the positive edge. The external trigger signal is applied at this point when the PRF INT toggle switch is in the EXT position.
- (5) OUT. SMA connector provides output to a 50-Ohm load.
- (6) AMP Control. The output amplitude is controlled by the front panel one-turn "AMP" control. Some reduction in the pulse width may occur as the output amplitude is reduced. It may be necessary to employ external attenuator pads for some demanding applications.

---

<sup>2</sup> The -KMP1 suffix provides a 20 ns output in place of the standard 200 ns.

Fig. 3: BACK PANEL CONTROLS

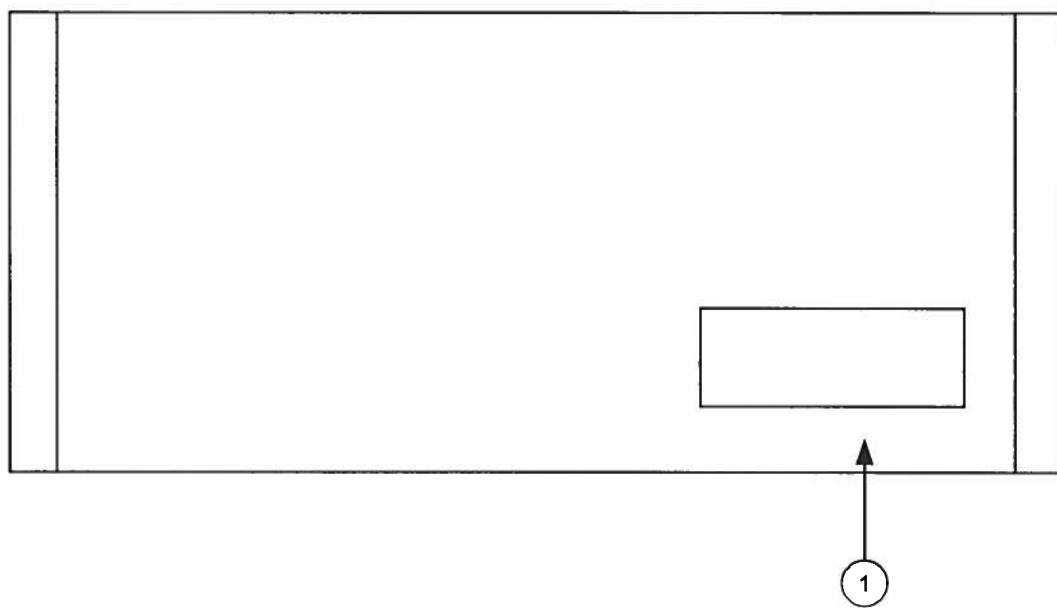



## BACK PANEL CONTROLS

1. FUSED CONNECTOR, VOLTAGE SELECTOR. The detachable power cord is connected at this point. In addition, the removable cord is adjusted to select the desired input operating voltage. The unit also contains the main power fuse.

For AC line voltages of 110-120V, the power selector card should be installed so that the "120" marking is visible from the rear of the instrument.

For AC line voltages of 220-240V, the power selector card should be installed so that the "240" marking is visible from the rear of the instrument.

If it is not set for the proper voltage, remove the fuse and then grasp the card with a pair of pliers and remove it. Rotate horizontally through 180 degrees. Reinstall the card and the correct fuse.

In the 120V setting, a 0.5A slow blow fuse is required. In the 240V setting, a 0.25A slow blow fuse is required.

## TOP COVER REMOVAL

The top cover may be removed by removing the four Philips screws on the top of the instrument. The top cover may then be slid back and off.

## POWER SUPPLY AND FUSE REPLACEMENT

This instrument has three main fuses, plus two spares. One, which protects the AC input, is located in the rear-panel power entry module, as described in the "Rear Panel Controls" section of this manual. If the power appears to have failed, check the AC fuse first.

The other two fuses (plus two spares) are located on the internal DC power supply, as shown below:

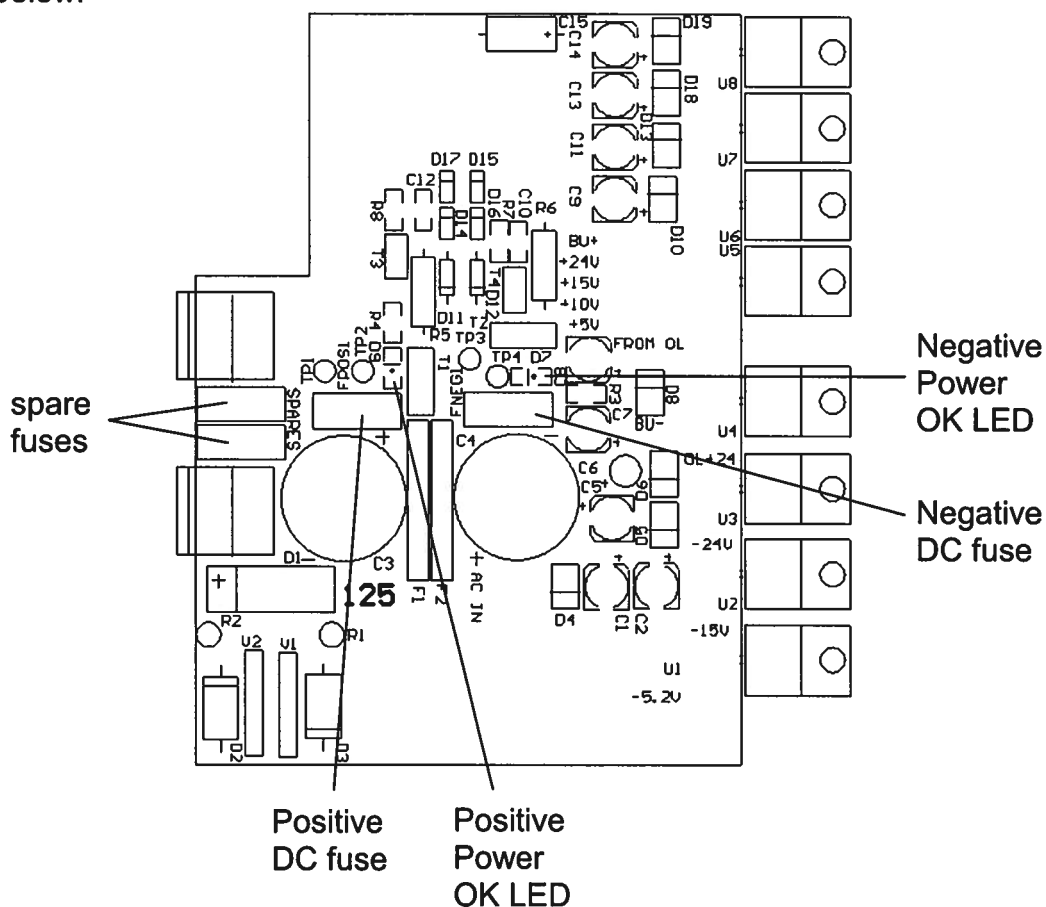

The four fuses on this circuit board are 0.5A slow-blow fuses, Littlefuse part number R452.500. (This fuse can be ordered from Digikey, [www.digikey.com](http://www.digikey.com). The Digikey part number is F1341CT-ND).

If you suspect that the DC fuses are blown, follow this procedure:

1. Remove the top cover, by removing the four Phillips screws on the top cover and then sliding the cover back and off.
2. Locate the two "Power OK" LEDs on the power supply circuit board, as illustrated above.
3. Turn on the instrument.
4. Observe the "Power OK" LEDs. If the fuses are not blown, the two LEDs will be lit (bright red). If one of the LEDs is not lit, the fuse next to it has blown.
5. Turn off the instrument.
6. If a fuse is blown, use needle-nose pliers to remove the blown fuse from its surface-mount holder.
7. Replace the fuse. (Two spare 0.5 Amp fuses are provided on the circuit board. They may be transferred to the active fuse locations using needle-nose pliers.)

March 8/2002  
(edition 1)