



# AVTECH ELECTROSYSTEMS LTD.

NANOSECOND WAVEFORM ELECTRONICS  
SINCE 1975

□ P.O. BOX 265  
OGDENSBURG, NY  
U.S.A. 13669-0265  
TEL: (315) 472-5270  
FAX: (613) 226-2802

TEL: 1-800-265-6681  
FAX: 1-800-561-1970

e-mail: [info@avtechpulse.com](mailto:info@avtechpulse.com)  
<http://www.avtechpulse.com>

□ P.O. BOX 5120 STN. F  
OTTAWA, ONTARIO  
CANADA K2C 3H4  
TEL: (613) 226-5772  
FAX: (613) 226-2802

## INSTRUCTIONS

### MODEL AVI-MP PULSE GENERATOR

S.N.: 10582

### WARRANTY

Avtech Electrosystems Ltd. warrants products of its manufacture to be free from defects in material and workmanship under conditions of normal use. If, within one year after delivery to the original owner, and after prepaid return by the original owner, this Avtech product is found to be defective, Avtech shall at its option repair or replace said defective item. This warranty does not apply to units which have been disassembled, modified or subjected to conditions exceeding the applicable specifications or ratings. This warranty is the extent of the obligation assumed by Avtech with respect to this product and no other warranty or guarantee is either expressed or implied.

### TECHNICAL SUPPORT

Phone: 613-226-5772 or 1-800-265-6681

Fax: 613-226-2802 or 1-800-561-1970

E-mail: [info@avtechpulse.com](mailto:info@avtechpulse.com)

World Wide Web: <http://www.avtechpulse.com>

## EC DECLARATION OF CONFORMITY

We

Avtech Electrosystems Ltd.  
Box 5120, LCD Merivale  
Ottawa, Ontario  
Canada K2C 3H4

declare that the AVI-MP  
pulse generator module (LTX P/N 874-9962-00) meets the intent of  
Directive 89/336/EEC for Electromagnetic Compatibility. Compliance  
pertains to the following specifications as listed in the official Journal  
of the European Communities:

EN 50081-1 Emission

EN 50082-1 Immunity



## TABLE OF CONTENTS

WARRANTY .....	2
EC DECLARATION OF CONFORMITY.....	3
TABLE OF CONTENTS .....	4
PULSE GENERATOR TEST ARRANGEMENT.....	5
GENERAL OPERATING INSTRUCTIONS.....	6
FIG. 1: OUTPUT PULSE WIDTH VERSUS CABLE LENGTH.....	7
FIG. 1A: OUTPUT PULSE WIDTH VERSUS CABLE LENGTH .....	8
FIG. 2: DELAY LINE CABLE LENGTH VERSUS PULSE REPETITION FREQUENCY PERIOD (MINIMUM PERIOD) .....	9
PERFORMANCE CHECK SHEET .....	10

## PULSE GENERATOR TEST ARRANGEMENT

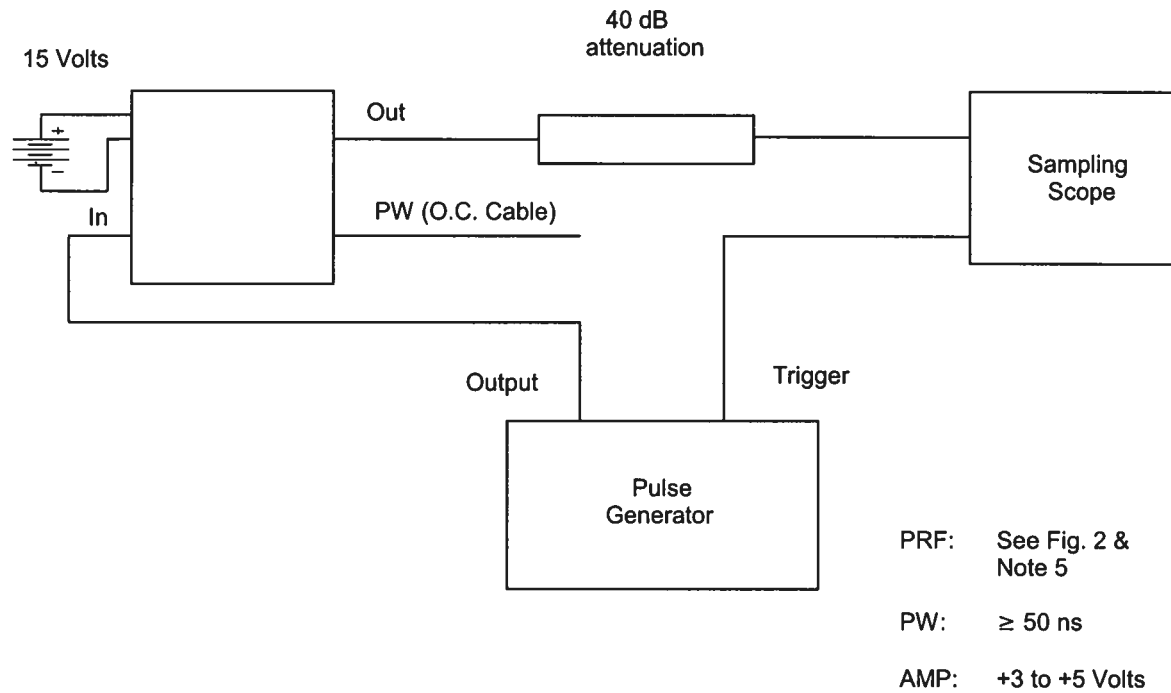

Power line: +15 Volts/0.25 Amps DC, shielded twisted pair, < 3 meters length

Control lines: 1 – Coaxial line, (trigger), SMA connector, < 3 meters length

Output: Coaxial, SMA, < 3 meters length

## GENERAL OPERATING INSTRUCTIONS

- 1) The bandwidth capability of components and instruments used to display the pulse generator output signal (attenuators, cables, connectors, etc.) should exceed several gigahertz.
- 2) The use of a 40 dB attenuation will insure a peak input signal to the sampling scope of less than one Volt.
- 3) In general, the pulse generator trigger delay control should be set in the 100 ns range. Other settings should be as shown in the above diagram. The Avtech pulse generator output is delayed with respect to the trigger input signal by about 50 ns. (typically).
- 4) The Model AVI output pulse width is a linear function of the length of open circuited coaxial cable connected to the "PW" port (see Fig. 1). The open circuited delay line should be formed from high-quality semi-rigid 50 Ohm coaxial cable (eg. 0.085 inch copper 50 Ohm semi-rigid). Miniature flexible coaxial cable such as RG 173 may be used but will result in a degraded fall time. In the absence of an external cable connected to the tune port, Model AVI-MP outputs an impulse of pulse width less than 1.0 ns.
- 5) The minimum pulse repetition frequency period is related to the delay line cable length (or pulse width) as shown in Fig. 2. If the PRF period for a given cable length is less than that specified in Fig. 2, the output pulse amplitude will be less than the specified value and prolonged operation in this mode could result in damage to the unit. Therefore, operation in or beyond the shaded region should be avoided.
- 6) The Model AVI pulse generator can withstand an infinite VSWR on the output port.
- 7) For additional assistance:

Tel: (613) 226-5772  
Fax: (613) 226-2802  
Email: [info@avtechpulse.com](mailto:info@avtechpulse.com)

FIG. 1

OUTPUT PULSE WIDTH VERSUS CABLE LENGTH

Model: AVI

S.N.:

(50 ohm 0.085 inch semi-rigid cable)

CABLE LENGTH (FT)

PULSE WIDTH (NSEC)

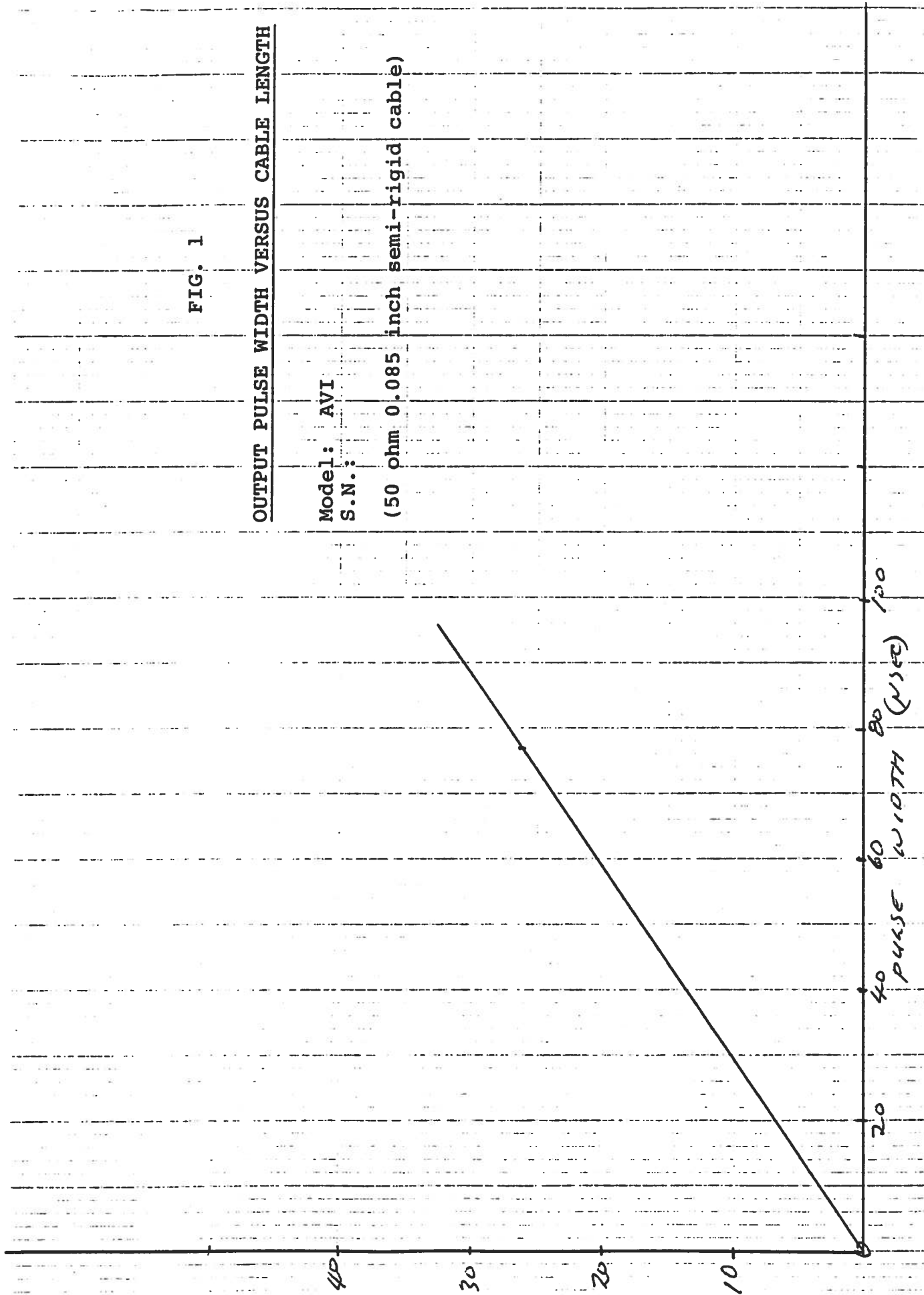

Fig. 1A

OUTPUT PULSE WIDTH VERSUS CABLE LENGTH

Model: AVI  
S.N.:  
(50 ohm 0.085 inch semi-rigid cable)

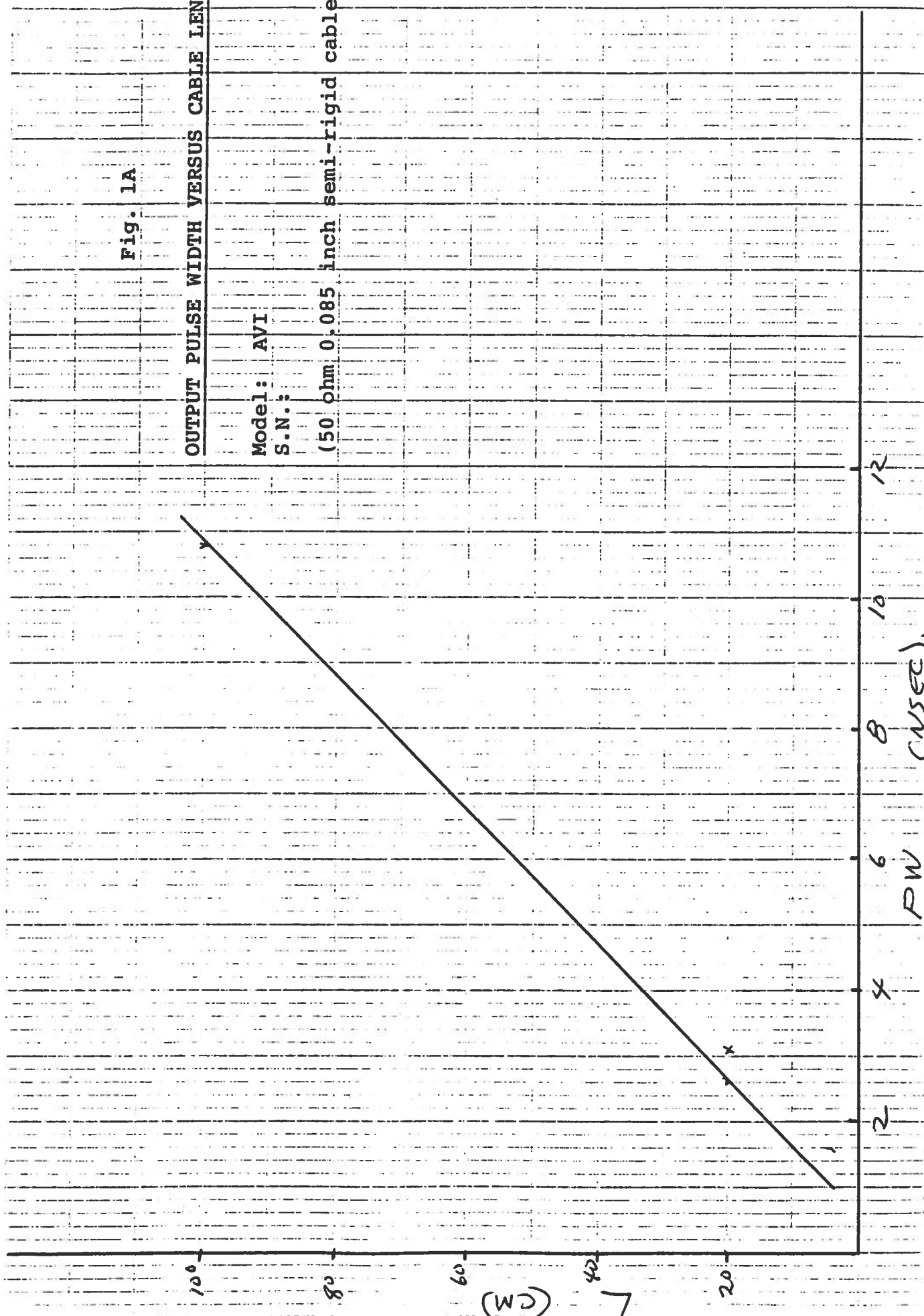

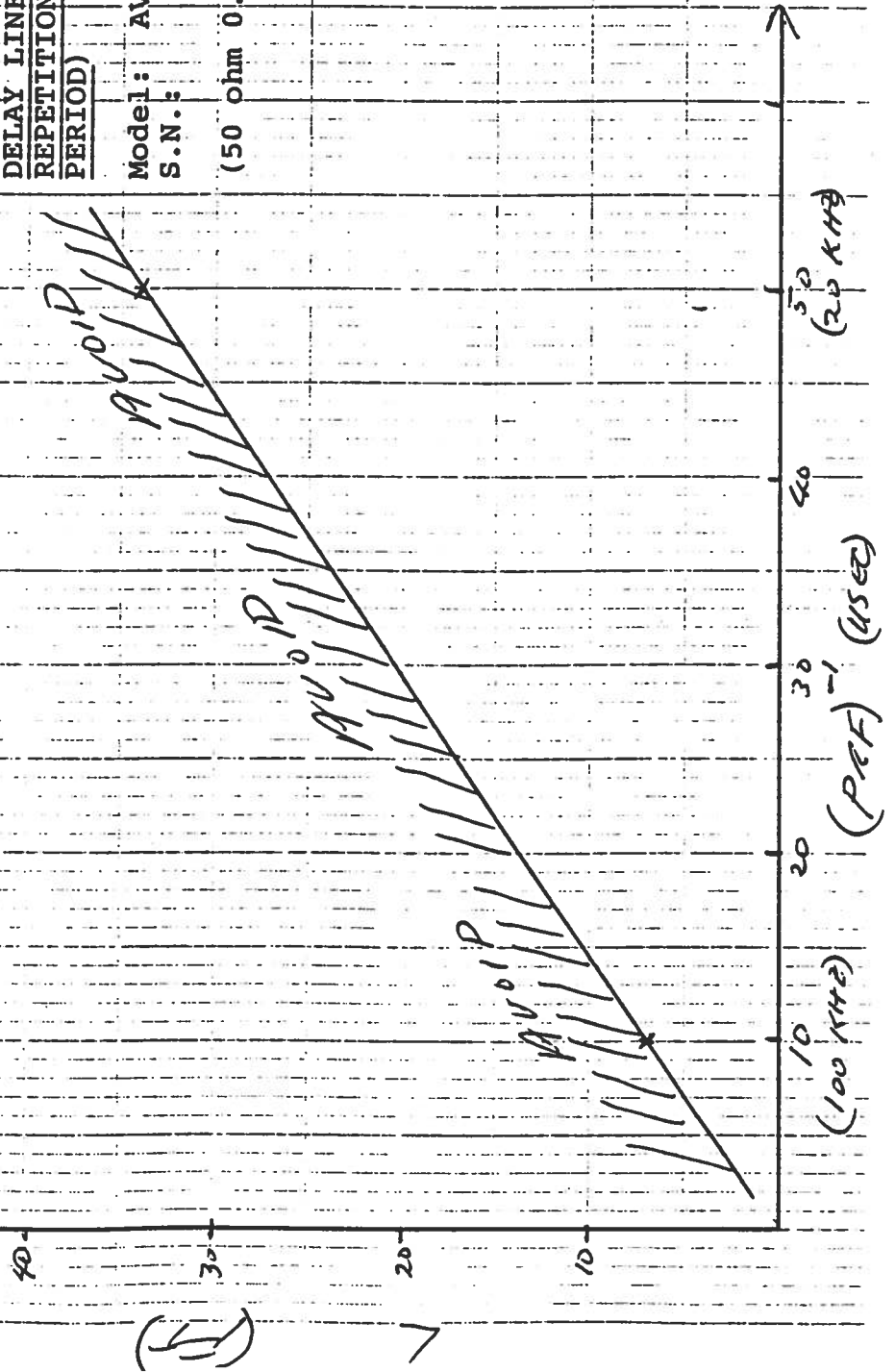

Fig. 2

DELAY LINE CABLE LENGTH VERSUS PULSE  
REPETITION FREQUENCY PERIOD (MINIMUM  
PERIOD)

Model: AVI  
S.N.:

(50 ohm 0.085 inch semi-rigid cable)



April 29, 2003

~~April 29, 2003~~