



**AVTECH ELECTROSYSTEMS LTD.**

NANOSECOND WAVEFORM ELECTRONICS  
SINCE 1975

□ P.O. BOX 265  
OGDENSBURG, NY  
U.S.A. 13669-0265  
TEL: (315) 472-5270  
FAX: (613) 226-2802

TEL: 1-800-265-6681  
FAX: 1-800-561-1970

e-mail: [info@avtechpulse.com](mailto:info@avtechpulse.com)  
<http://www.avtechpulse.com>

□ P.O. BOX 5120 STN. F  
OTTAWA, ONTARIO  
CANADA K2C 3H4  
TEL: (613) 226-5772  
FAX: (613) 226-2802

## INSTRUCTIONS

**MODEL AV-1011-B**

**0 TO  $\pm$ 100 VOLTS, 2 AMP, 1 MHz  
GENERAL PURPOSE LAB PULSE GENERATOR  
AND LASER DIODE DRIVER  
WITH IEEE 488.2 AND RS-232 CONTROL**

**SERIAL NUMBER: \_\_\_\_\_**

### WARRANTY

Avtech Electrosystems Ltd. warrants products of its manufacture to be free from defects in material and workmanship under conditions of normal use. If, within one year after delivery to the original owner, and after prepaid return by the original owner, this Avtech product is found to be defective, Avtech shall at its option repair or replace said defective item. This warranty does not apply to units which have been disassembled, modified or subjected to conditions exceeding the applicable specifications or ratings. This warranty is the extent of the obligation assumed by Avtech with respect to this product and no other warranty or guarantee is either expressed or implied.

### TECHNICAL SUPPORT

Phone: 613-226-5772 or 1-800-265-6681

Fax: 613-226-2802 or 1-800-561-1970

E-mail: [info@avtechpulse.com](mailto:info@avtechpulse.com)

World Wide Web: <http://www.avtechpulse.com>

## TABLE OF CONTENTS

<b>WARRANTY</b>	<b>2</b>
<b>TECHNICAL SUPPORT</b>	<b>2</b>
<b>TABLE OF CONTENTS</b>	<b>3</b>
<b>INTRODUCTION</b>	<b>5</b>
<b>LABVIEW DRIVERS</b>	<b>5</b>
<b>SPECIFICATIONS</b>	<b>7</b>
<b>INSTALLATION</b>	<b>8</b>
<b>VISUAL CHECK</b>	<b>8</b>
<b>PLUGGING IN THE INSTRUMENT</b>	<b>8</b>
<b>FRONT PANEL CONTROLS</b>	<b>9</b>
<b>REAR PANEL CONTROLS</b>	<b>11</b>
<b>GENERAL INFORMATION</b>	<b>13</b>
<b>BASIC PULSE CONTROL</b>	<b>13</b>
<b>TRIGGER MODES</b>	<b>15</b>
<b>PULSE WIDTH MODES</b>	<b>15</b>
<b>GATING MODES</b>	<b>15</b>
<b>MINIMIZING WAVEFORM DISTORTIONS</b>	<b>16</b>
<b>OUTPUT IMPEDANCE</b>	<b>16</b>
<b>GENERATING LOW-VOLTAGE WAVEFORMS</b>	<b>16</b>
<b>USE 50Ω TRANSMISSION LINES</b>	<b>16</b>
<b>USE LOW-INDUCTANCE LOADS</b>	<b>16</b>
<b>TYPICAL WAVEFORMS</b>	<b>18</b>
<b>MECHANICAL INFORMATION</b>	<b>20</b>
<b>TOP COVER REMOVAL</b>	<b>20</b>
<b>RACK MOUNTING</b>	<b>20</b>
<b>ELECTROMAGNETIC INTERFERENCE</b>	<b>20</b>
<b>OPERATIONAL CHECK</b>	<b>21</b>
<b>PROGRAMMING YOUR PULSE GENERATOR</b>	<b>24</b>
<b>KEY PROGRAMMING COMMANDS</b>	<b>24</b>
<b>ALL PROGRAMMING COMMANDS</b>	<b>24</b>

***PERFORMANCE CHECK SHEET***

---

Manual Reference: Q:\office\instructword\AV-1011\av-1011-b, edition 4.doc, created August 13, 1999

## INTRODUCTION

The AV-1011-B is a high performance, GPIB and RS232-equipped instrument capable of 200 W peak pulse power at repetition rates up to 1 MHz. The output amplitude is variable up to  $\pm 100$  V into  $50 \Omega$ . Pulse delay, advance and width are variable up to 1 ms. Rise and fall times are fixed at less than 10 ns. The AV-1011-B provides single or double pulse output and can be triggered or gated by an external source. A front-panel pushbutton can also be used to trigger the instrument. The output pulse width can be set to follow an input trigger pulse width and the output amplitude can be controlled by an externally applied 0 to +10 Volts DC control voltage.

The AV-1011-B features front panel keyboard and adjust knob control of the output pulse parameters along with a four line by 40 character back-lit LCD display of the output amplitude, polarity, pulse width, pulse repetition frequency, source resistance and delay. The instrument includes memory to store up to four complete instrument setups. The operator may use the front panel or the computer interface to store a complete "snapshot" of all key instrument settings, and recall this setup at a later time.

The source resistance can be set at either 2 or  $50 \Omega$ . In the  $2 \Omega$  setting, the output amplitude is variable from 0.5 to 100V. In the  $50 \Omega$  setting the amplitude is variable from 0.3 to 50V to  $50 \Omega$ , or to 100 Volts to a high impedance. The output amplitude can also be controlled externally by applying a 0 to +10V DC control voltage to a rear panel BNC connector.

The MOSFET output stages will safely withstand any combination of front panel control settings, output open or short circuits, and high duty cycles. An internal power supply monitor removes the power to the output stage for five seconds if an average power overload exists. After that time, the unit operates normally for one second, and if the overload condition persists, the power is cut again. This cycle repeats until the overload is removed. With a  $50 \Omega$  load the unit will withstand duty cycles as high as 10% but with high impedance loads the duty cycle may be as high as 80%. The output stage will source up to 2.5 Amps (and will automatically shut down if the load current exceeds 2.5 Amps).

Application notes describing the use of the AV-1010 and AV-1011 families of pulse generators are available on the Avtech web site, <http://www.avtechpulse.com>.

## LABVIEW DRIVERS

A LabVIEW driver for the AV-1011-B is available for download at <http://www.avtechpulse.com/labview>. A copy is also available in National Instruments' Instrument Driver Library at <http://www.natinst.com/>.

## SPECIFICATIONS

Model:	AV-1011-B
Pulse output amplitude <sup>1</sup> : ( $R_L = 50 \Omega$ )	0 to 100 Volts (for $Z_{OUT} = 2\Omega$ ) 0 to 50 Volts (for $Z_{OUT} = 50\Omega$ )
Rise time, fall time:	$\leq 10$ ns
Pulse width <sup>2</sup> :	100 ns to 1 ms
Pulse repetition rate:	1 Hz to 1.0 MHz
GPIB control:	Included as a standard feature.
Maximum duty cycle:	10% for $R_L=50\Omega$ and amplitude $\geq 20V$ 25% for $R_L=50\Omega$ and amplitude $< 20V$ 80% for $R_L>10k\Omega$
Output impedance:	$2\Omega$ or $50\Omega$
Output polarity:	Positive or negative
Jitter:	Pulse width: $\leq 0.1\%$ , (typically $\leq 0.01\%$ ) Delay/Advance: $\leq 0.1\%$ , + 0.5 ns Period: $\leq 0.1\%$ , + 0.5 ns
Pulse aberrations:	$\leq \pm 5\%$ of amplitude
Double pulse spacing:	100 ns to 1 ms
Sync delay:	$\pm 100$ ns to $\pm 1$ ms (between sync out and main pulse output)
Sync output:	+ 3 Volts, 50 ns ( $R_L > 1$ K)
Gated operation:	Has a programmable high/low synchronous/asynchronous gate
External trigger:	+3 to +5V, $\leq 1$ MHz, PW $\geq 50$ ns
Minimum propagation delay external trigger modes:	Advance: 200 ns Delay: 300 ns Double pulse: 200 ns PW <sub>IN</sub> = PW <sub>OUT</sub> : 100 ns
Output protection:	The output is protected against short circuits, open circuits, and high duty cycle
Connectors:	BNC female
Power source:	120/240 Volts, $\pm 10\%$ (switchable) 48 Hz to 66 Hz, 100 VA maximum
Dimensions (H x W x D):	100 mm x 430 mm x 375 mm (3.9" x 17" x 14.8")
Weight:	$\leq 10$ kg (22 lbs)
Chassis material:	Aluminum. Anodized aluminum front panel with cast aluminum side panels (with blue-gray plastic trim) and aluminum top and bottom panels with blue-gray plastic trim.
Operating temperature:	+ 10° C to + 50° C
Accessories furnished:	one detachable 6' power cord, one operation-maintenance manual
Option available:	19" rack mount kit (-R5)

- 1) The output amplitude may also be controlled by applying 0 to +10 Volts DC to a rear panel banana connector.
- 2) The output pulse width may also be controlled externally by applying a TTL level trigger of the desired width to a rear panel BNC connector (PW IN = PW OUT mode).

## INSTALLATION

### VISUAL CHECK

After unpacking the instrument, examine to ensure that it has not been damaged in shipment. Visually inspect all connectors, knobs, liquid crystal displays (LCDs), and the handles. Confirm that a power cord and two instrumentation manuals (this manual and the "OP1B Interface Programming Manual") are with the instrument. If the instrument has been damaged, file a claim immediately with the company that transported the instrument.

### PLUGGING IN THE INSTRUMENT

Examine the rear of the instrument. There will be a male power receptacle, a fuse holder and the edge of the power selector card visible. Confirm that the power selector is in the correct orientation - it should be marked either 120 or 240, indicating whether it expects 120V AC or 240V AC. If it is not set for the proper voltage, remove the fuse and then grasp the card with a pair of pliers and remove it. Rotate horizontally through 180 degrees. Reinstall the card and the correct fuse. In the 120V setting, a 1.0A slow blow fuse is required. In the 240V setting, a 1/2A slow blow fuse is required.



## FRONT PANEL CONTROLS

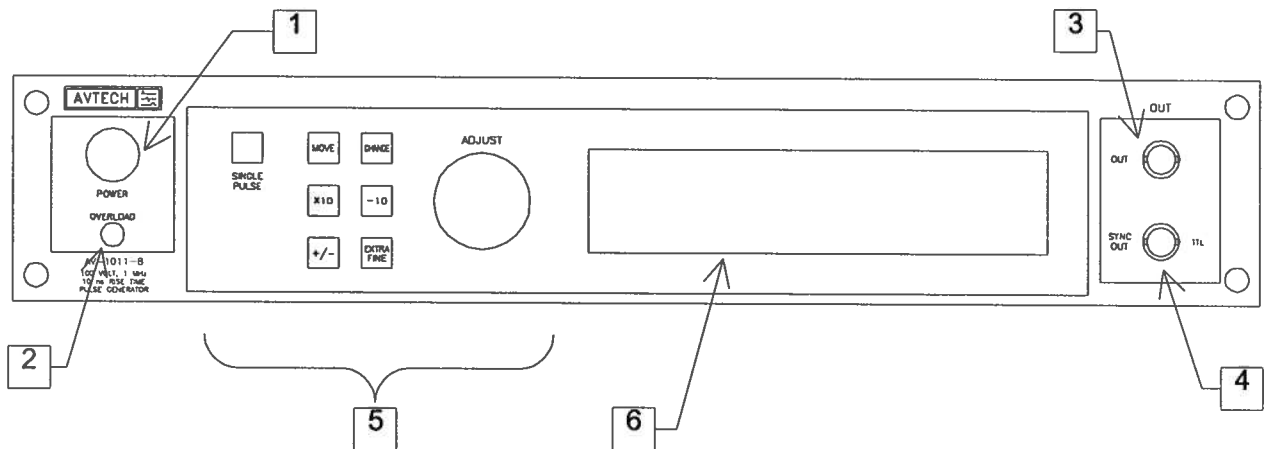

1. **POWER Switch.** The POWER push button switch applies AC prime power to the primaries of the transformer, turning the instrument on. The push button lamp (#382 type) is connected to the internal +15V DC supply.
2. **OVERLOAD.** The AV-1011-B is protected in its internal software against conflicting or dangerous settings. As an additional protective measure, an automatic overload circuit exists, which controls the front panel overload light. If the unit is overloaded (by operating at an exceedingly high duty cycle or by operating into a very low impedance), the protective circuit will turn the output of the instrument OFF and turn the indicator light ON. The light will stay ON (i.e. output OFF) for about 5 seconds after which the instrument will attempt to turn ON (i.e. light OFF) for about 1 second. If the overload condition persists, the instrument will turn OFF again (i.e. light ON) for another 5 seconds. If the overload condition has been removed, the instrument will turn on and resume normal operation.

This overload indicator is only likely to come on in two situations:

- Briefly at startup. This is not a cause for concern.
- When the instrument is set to operate into a high impedance load ( $R_L > 10k\Omega$ ) but a low impedance load is connected instead. In this case, turn off the instrument and connect the proper load, or set the load impedance setting to the proper value.

Note that the output stage will safely withstand a short circuited load condition.

3. **OUT CONNECTOR.** This BNC connector provides the main output signal, into load impedances of  $50\Omega$  or higher.
4. **SYNC OUT.** This connector supplies a SYNC output that can be used to trigger other equipment, particularly oscilloscopes. This signal leads (or lags) the main output by a duration set by the "DELAY" controls and has an approximate amplitude of +3 Volts to  $R_L > 1K$  with a pulse width of approximately 50 ns.
5. **KEYPAD.**

Control Name	Function
MOVE	This moves the arrow pointer on the display.
CHANGE	This is used to enter the submenu, or to select the operating mode, pointed to by the arrow pointer.
$\times 10$	If one of the adjustable numeric parameters is displayed, this increases the setting by a factor of ten.
$\div 10$	If one of the adjustable numeric parameters is displayed, this decreases the setting by a factor of ten.
+/-	If one of the adjustable numeric parameters is displayed, and this parameter can be both positive or negative, this changes the sign of the parameter.
EXTRA FINE	This changes the step size of the ADJUST knob. In the extra-fine mode, the step size is twenty times finer than in the normal mode. This button switches between the two step sizes.
ADJUST	This large knob adjusts the value of any displayed numeric adjustable values, such as frequency, pulse width, etc. The adjust step size is set by the "EXTRA FINE" button.  When the main menu is displayed, this knob can be used to move the arrow pointer.

6. **LIQUID CRYSTAL DISPLAY (LCD).** This LCD is used in conjunction with the keypad to change the instrument settings. Normally, the main menu is displayed, which lists the key adjustable parameters and their current values. The "OP1B Interface Programming Manual" describes the menus and submenus in detail.

## REAR PANEL CONTROLS

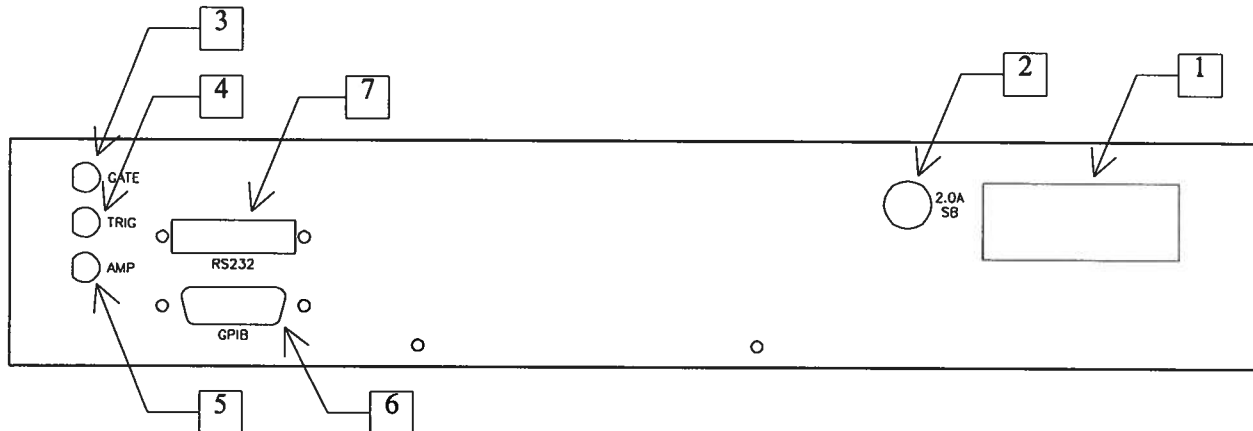

1. **AC POWER INPUT**. A three-pronged recessed male connector is provided on the back panel for AC power connection to the instrument. Also contained in this assembly is a 1.0A slow blow fuse and a removable card that can be removed and repositioned to switch between 120V AC in and 240V AC in.
2. **2.0A SB**. This fuse protects the output stage if the output duty cycle rating is exceeded.
3. **GATE**. This TTL-level (0 and +5V) logic input can be used to gate the triggering of the instrument. This input can be either active high or active low, depending on the front panel settings or programming commands. (The instrument triggers normally when this input is unconnected).
4. **TRIG**. This TTL-level (0 and +5V) logic input can be used to trigger the instrument, if the instrument is set to triggering externally. The instrument triggers on the rising edge of this input. The instrument can also be set such that the output pulse width tracks the pulse width on this input, or the output pulse width can be set independently.
5. **AMP**. The output amplitude can be set to track the DC voltage on this input. This input voltage may range between 0 and +10 Volts, which corresponds to minimum and maximum output amplitudes, respectively. (In normal operation, the output amplitude is set by the front-panel controls or via the computer interface.)
6. **GPIB Connector**. A standard GPIB cable can be attached to this connector to allow the instrument to be computer-controlled. See the "OP1B Interface Programming Manual" for more details on GPIB control.
7. **RS-232 Connector**. A standard serial cable with a 25-pin male connector can be attached to this connector to allow the instrument to be computer-controlled. See

the "OP1B Interface Programming Manual" for more details on RS-232 control.

## GENERAL INFORMATION

### BASIC PULSE CONTROL

This instrument can be triggered by its own internal clock or by an external TTL trigger signal. In either case, two output channels respond to the trigger: OUT and SYNC. The OUT channel is the signal that is applied to the load. Its amplitude and pulse width are variable. The SYNC pulse is a fixed-width TTL-level reference pulse used to trigger oscilloscopes or other measurement systems. When the delay is set to a positive value the SYNC pulse precedes the OUT pulse. When the delay is set to a negative value the SYNC pulse follows the OUT pulse.

These pulses are illustrated below, assuming internal triggering and a positive delay:

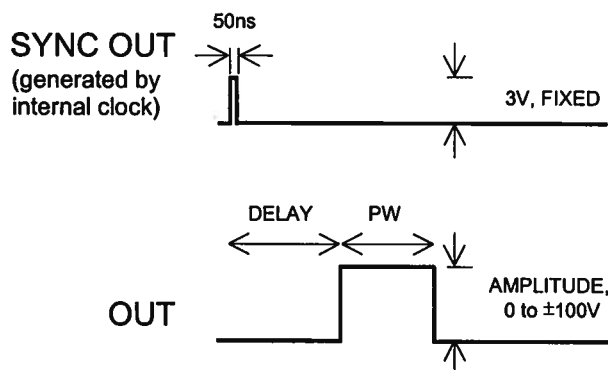

*Figure A*

If the delay is negative, the order of the SYNC and OUT pulses is reversed:

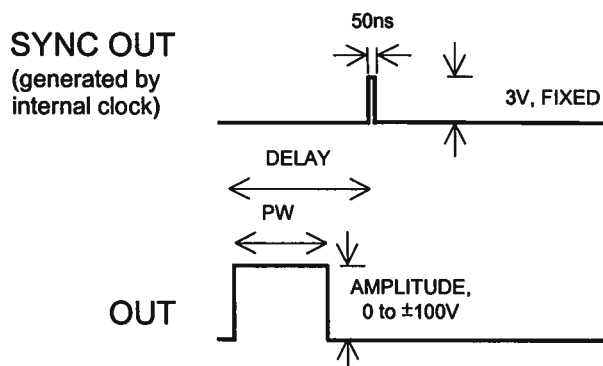

*Figure B*

The next figure illustrates the relationship between the signal when an external TTL-level trigger is used:

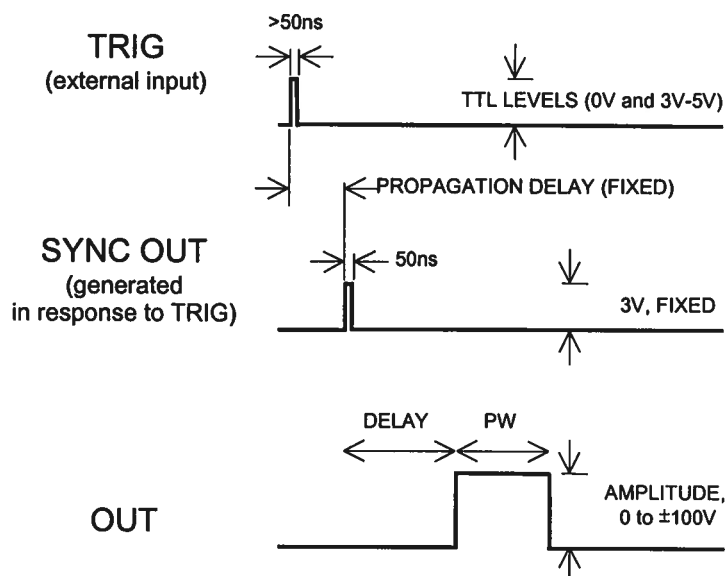

Figure C

As before, if the delay is negative, the order of the SYNC and OUT pulses is reversed.

The last figure illustrates the relationship between the signal when an external TTL-level trigger is used in the  $PW_{\text{IN}}=PW_{\text{OUT}}$  mode. In this case, the output pulse width equals the external trigger's pulse width (approximately), and the delay circuit is bypassed:

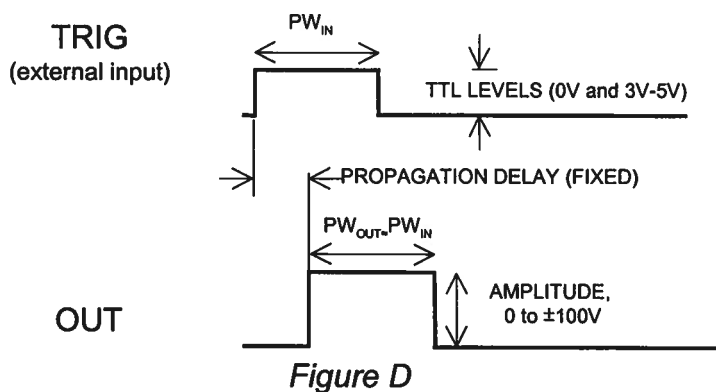

Figure D

The delay, pulse width, and frequency (when in the internal mode), of the OUT pulse can be varied with front panel controls or via the GPIB or RS-232 computer interfaces.

## TRIGGER MODES

This instrument has four trigger modes:

- Internal Trigger: the instrument controls the trigger frequency, and generates the clock internally.
- External Trigger: the instrument is triggered by an external TTL-level clock on the back-panel TRIG connector.
- Manual Trigger: the instrument is triggered by the front-panel "SINGLE PULSE" pushbutton.
- Hold Trigger: the instrument is set to not trigger at all.

These modes can be selected using the front panel trigger menu, or by using the appropriate programming commands. (See the "OP1B Interface Programming Manual" for more details.)

## PULSE WIDTH MODES

This instrument has two pulse width modes:

- Normal: the instrument controls the output pulse width.
- $PW_{IN}=PW_{OUT}$ : the output pulse width equals the pulse width of the trigger signal on the "TRIG" connector. The instrument must be in the external trigger mode.

These modes can be selected using the front panel pulse width menu, or by using the appropriate programming commands. (See the "OP1B Interface Programming Manual" for more details.)

## GATING MODES

Triggering can be suppressed by a TTL-level signal on the rear-panel GATE connector. The instrument can be set to stop triggering when this input high or low, using the front-panel gate menu or the appropriate programming commands. This input can also be set to act synchronously or asynchronously. When set to asynchronous mode, the GATE will disable the output immediately. Output pulses may be truncated. When set to synchronous mode, the output will complete the full pulse width if the output is high, and then stop triggering. No pulses are truncated in this mode.

## MINIMIZING WAVEFORM DISTORTIONS

### OUTPUT IMPEDANCE

The output impedance of the AV-1011-B can be set at  $2\Omega$  or  $50\Omega$  using the front panel controls (or GPIB/RS-232 commands).

When driving a high impedance load (i.e.,  $R_L \gg 50\Omega$ ), the output impedance should always be set to  $50\Omega$ . This will minimize waveform ringing and transmission line reflections, without adversely affecting the pulse amplitude.

When driving a  $50\Omega$  load, it is also highly desirable to set the output impedance to  $50\Omega$ . However, the output impedance and the load resistance will cause a resistive voltage-divider effect, reducing the output amplitude at the load by a factor of two. Thus, the  $50\Omega$  output impedance can only be used to generate amplitudes of 0 to  $\pm 50V$ .

### GENERATING LOW-VOLTAGE WAVEFORMS

When generating low-voltage waveforms, the output waveforms will have much less distortion (i.e. ringing) if the output impedance is set to  $50\Omega$ . As noted above, if the pulse generator is driving a  $50\Omega$  load, this will result in a resistive-divider effect – for instance, to obtain the best possible +5V waveform into a  $50\Omega$  load, set the pulse generator output impedance to  $50\Omega$ , and the amplitude to +10V.

### USE $50\Omega$ TRANSMISSION LINES

Connect the load to the pulse generator with  $50\Omega$  transmission lines (e.g. RG-58 or RG-174 cable). If possible, use a  $50\Omega$  load. If the actual device under test has a high impedance, consider adding a  $50\Omega$  termination in parallel with the load to properly terminate the transmission line.

Setting the pulse generator output impedance to  $50\Omega$  will “back-match” the transmission line, resulting in improved performance.

### USE LOW-INDUCTANCE LOADS

Lenz's Law predicts that for an inductive voltage spike will be generated when the current through an inductance changes. Specifically,  $V_{\text{SPIKE}} = L \times di_{\text{LOAD}}/dt$ , where  $L$  is the inductance,  $i_{\text{LOAD}}$  is the load current change, and  $t$  is time. For this reason, it is important to keep any parasitic in the load low. This means keeping wiring short, and



using low inductance components. In particular, wire-wound resistors should be avoided.

## TYPICAL WAVEFORMS

Figure 1 shows typical output waveforms with the pulse generator amplitude set at +100V, the pulse width at 500 ns, and the output impedance set to  $2\Omega$ . The pulse generator is connected to a  $50\Omega$  load through an 8" length of RG-174 cable.

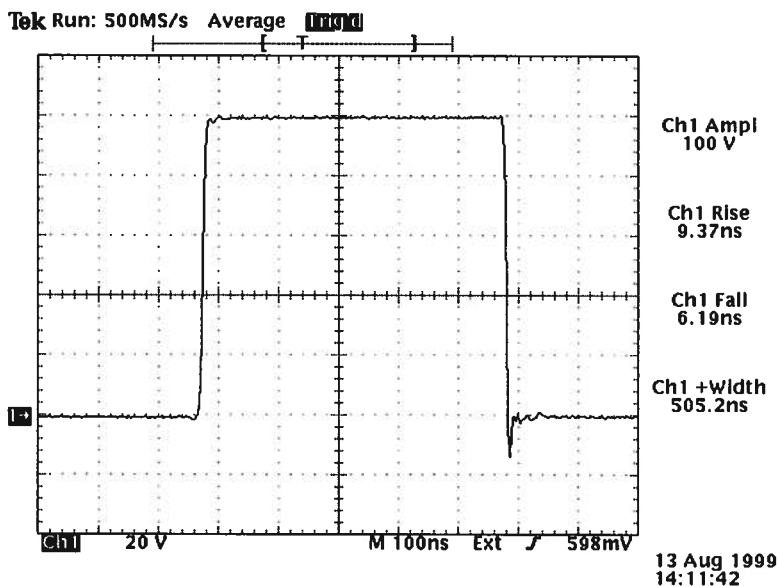

*Figure 1 (20V/div, 100 ns/div)*

Figure 2 shows the results with similar settings, except that the output impedance has been set to  $50\Omega$ . As a result, the amplitude at the load has fallen by a factor of two, and the waveform shows less distortion on the very fast falling edge.

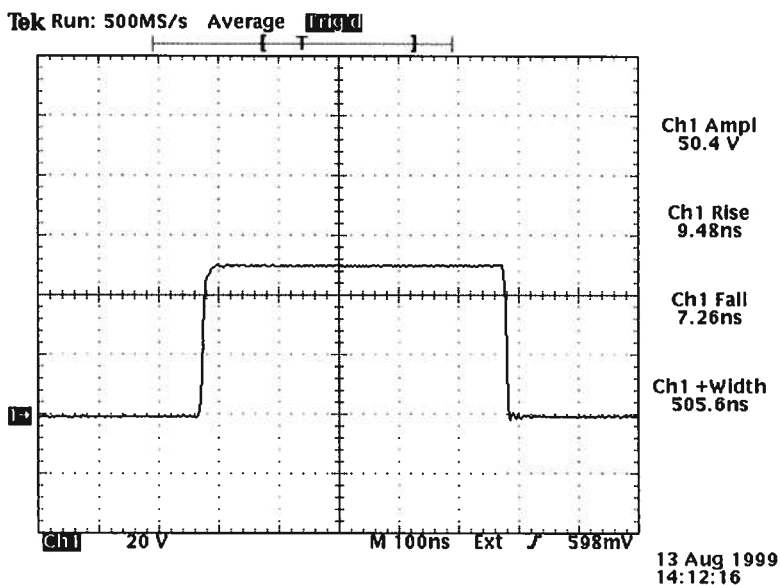

*Figure 2 (20V/div, 100 ns/div)*

Figures 3 and 4 show operation at low voltages. Figure 3 shows typical output waveforms with the pulse generator amplitude set at +5V, the pulse width at 500 ns, and the output impedance set to  $2\Omega$ . The pulse generator is again connected to a  $50\Omega$  load through an 8" length of RG-174 cable. At this low amplitude, the waveform is dominated by undesirable ringing.

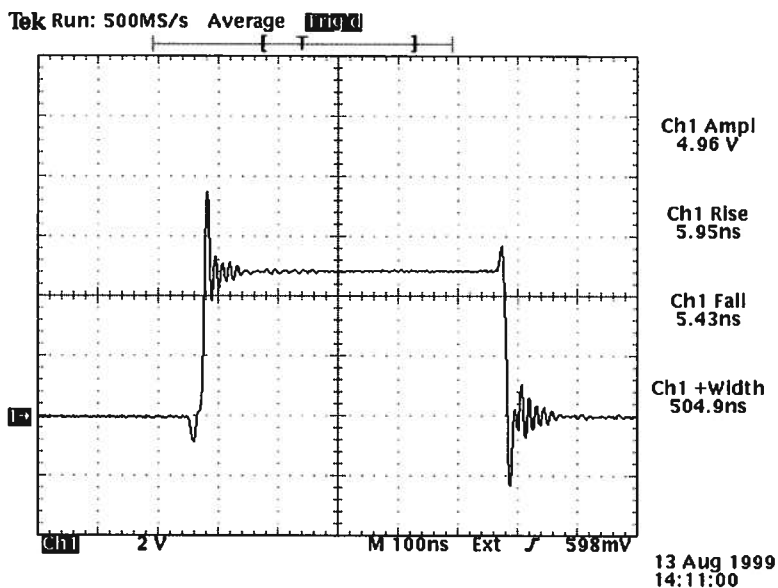

Figure 3 (2V/div, 100 ns/div)

This situation can be remedied by setting the output impedance to  $50\Omega$ , and doubling the set amplitude to +10V to compensate for the voltage-divider effect. Figure 4 shows the vastly improved waveform that results.

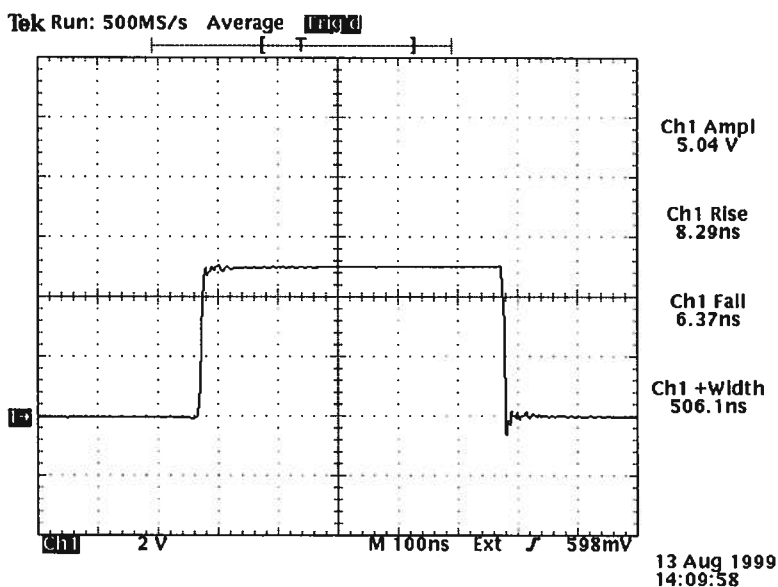

Figure 4 (2V/div, 100 ns/div)

## MECHANICAL INFORMATION

### TOP COVER REMOVAL

The interior of the instrument may be accessed by removing the four Phillips screws on the top panel. With the four screws removed, the top cover may be slid back (and off).

### RACK MOUNTING

A rack mounting kit is available. The -R5 rack mount kit may be installed after first removing the one Phillips screw on the side panel adjacent to the front handle.

### ELECTROMAGNETIC INTERFERENCE

To prevent electromagnetic interference with other equipment, all used outputs should be connected to shielded  $50\Omega$  loads using shielded  $50\Omega$  coaxial cables. Unused outputs should be terminated with shielded  $50\Omega$  BNC terminators or with shielded BNC dust caps, to prevent unintentional electromagnetic radiation. All cords and cables should be less than 3m in length.

## OPERATIONAL CHECK

This section describes a sequence to confirm the basic operation of the instrument. It should be performed after receiving the instrument. It is a useful learning exercise as well.

Before proceeding with this procedure, finish reading this instruction manual thoroughly. Then read the "Local Control" section of the "OP1B Interface Programming Manual" thoroughly. The "Local Control" section describes the front panel controls used in this operational check - in particular, the MOVE, CHANGE, and ADJUST controls.

1. Connect a cable from the SYNC OUT connector to the TRIG input of an oscilloscope. Connect a 10W (or higher) 50 $\Omega$  load to the OUT connector and place the scope probe across this load. Set the oscilloscope to trigger externally with the vertical setting at 5 Volts/div and the horizontal setting at 1 us/div.
2. Turn on the AV-1011-B. The main menu will appear on the LCD.
3. To set the AV-1011-B to trigger from the internal clock at a PRF of 10 kHz:
  - a) The arrow pointer should be pointing at the frequency menu item. If it is not, press the MOVE button until it is.
  - b) Press the CHANGE button. The frequency submenu will appear. Rotate the ADJUST knob until the frequency is set at 10 kHz.
  - c) The arrow pointer should be pointing at the "Internal" choice. If it is not, press MOVE until it is.
  - d) Press CHANGE to return to the main menu.
4. To set the delay to 1  $\mu$ s:
  - a) Press the MOVE button until the arrow pointer is pointing at the delay menu item.
  - b) Press the CHANGE button. The delay submenu will appear. Rotate the ADJUST knob until the delay is set at 1  $\mu$ s.
  - c) The arrow pointer should be pointing at the "Normal" choice. If it is not, press MOVE until it is.

- d) Press CHANGE to return to the main menu.
5. To set the pulse width to 1  $\mu\text{s}$ :
    - a) Press the MOVE button until the arrow pointer is pointing at the pulse width menu item.
    - b) Press the CHANGE button. The pulse width submenu will appear. Rotate the ADJUST knob until the pulse width is set at 1  $\mu\text{s}$ .
    - c) The arrow pointer should be pointing at the "Normal" choice. If it is not, press MOVE until it is.
    - d) Press CHANGE to return to the main menu.
  6. The main menu display should show that the output impedance ( $Z_{\text{OUT}}$ ) is set at  $2\Omega$ , and the load impedance ( $R_L$ ) is set at  $50\Omega$ . If they are different, change the settings.
  7. At this point, nothing should appear on the oscilloscope.
  8. To enable the output:
    - a) Press the MOVE button until the arrow pointer is pointing at the output menu item.
    - b) Press the CHANGE button. The output submenu will appear.
    - c) Press MOVE until the arrow pointer is pointing at the "ON" choice.
    - d) Press CHANGE to return to the main menu.
  9. To change the output amplitude:
    - a) Press the MOVE button until the arrow pointer is pointing at the amplitude menu item.
    - b) Press the CHANGE button. The amplitude submenu will appear. Rotate the ADJUST knob until the amplitude is set at 10V.
    - c) Observe the oscilloscope. You should see 1  $\mu\text{s}$  wide, 10V pulses.
    - d) Rotate the ADJUST knob. The amplitude as seen on the oscilloscope should vary. Set it at 20V.

- e) Press CHANGE to return to the main menu.
10. Try varying the pulse width, by repeating step (5). As you rotate the ADJUST knob, the pulse width on the oscilloscope will change. It should agree with the displayed value. Stay below 10% duty cycle.
  11. Go to the output impedance menu, and set the output impedance ( $Z_{OUT}$ ) to  $50\ \Omega$ . Return to the main menu. If a  $50\ \Omega$  load is attached to the output (see step 1) the amplitude should fall by a factor of 2, to 10V.
  12. To change the output amplitude polarity:
    - a) Press the MOVE button until the arrow pointer is pointing at the amplitude menu item.
    - b) Press the CHANGE button. The amplitude submenu will appear.
    - c) Press the "+/-" button. The amplitude as seen on the oscilloscope should become negative.
    - d) Press CHANGE to return to the main menu.

This completes the operational check.

## PROGRAMMING YOUR PULSE GENERATOR

### KEY PROGRAMMING COMMANDS

The “OP1B Interface Programming Manual” describes in detail how to connect the pulse generator to your computer, and the programming commands themselves. A large number of commands are available; however, normally you will only need a few of these. Here is a basic sample sequence of commands that might be sent to the instrument after power-up:

*rst	(resets the instrument)
trigger:source internal	(selects internal triggering)
frequency 1000 Hz	(sets the frequency to 1000 Hz)
pulse:width 10 us	(sets the pulse width to 10 us)
pulse:delay 1 us	(sets the delay to 1 us)
output:load 50	(tells the instrument that you are using a 50Ω load. This affects the duty cycle limit. The only other allowed setting is output:load 10000.)
output:impedance 2	(sets the output impedance to 2Ω. The only other allowed setting is output:impedance 50.)
volt 50	(sets the amplitude to 50 V)
output on	(turns on the output)

These commands will satisfy 90% of your programming needs.

### ALL PROGRAMMING COMMANDS

For more advanced programmers, a complete list of the available commands is given below. These commands are described in detail in the “OP1B Interface Programming Manual”. (Note: this manual also includes some commands that are not implemented in this instrument. They can be ignored.)

<u>Keyword</u>	<u>Parameter</u>	<u>Notes</u>
LOCAL		
OUTPut:		
:LOAD	50   10000	
:[STATe]	<boolean value>	
:IMPedance	<numeric value>	
:PROTection		
:TRIPped?		[query only]
REMOTE		
[SOURce]:		
:FREQUency		
[:CW   FIXed]	<numeric value>	
[SOURce]:		



:PULSe		
:PERiod	<numeric value>	
:WIDTh	<numeric value>   IN	
:DCYClE	<numeric value>	
:HOLD	WIDTh   DCYClE	
:DELay	<numeric value>	
:DOUBle		
[:STATE]	<boolean value>	
:DELay	<numeric value>	
:GATE		
:TYPE	ASYNc   SYNc	
:LEVel	HIGH   LOW	
[SOURce]:		
:VOLTage		
[:LEVel]		
[:IMMediate]		
[:AMPLitude]	<numeric value>   EXTernal	
:PROTectiOn		
:TRIPped?		[query only]
STATUS:		
:OPERation		
:[EVENT]?		[query only, always returns "0"]
:CONDition?		[query only, always returns "0"]
:ENABle	<numeric value>	[implemented but not useful]
:QUESTionable		
:[EVENT]?		[query only, always returns "0"]
:CONDition?		[query only, always returns "0"]
:ENABle	<numeric value>	[implemented but not useful]
SYSTEM:		
:COMMunicate		
:GPIB		
:ADDReSS	<numeric value>	
:SERial		
:CONTRol		
:RTS	ON   IBFull   RFR	
:[RECeive]		
:BAUD	1200   2400   4800   9600	
:BITS	7   8	
:ECHO	<boolean value>	
:PARity		
:[TYPE]	EVEN   ODD   NONE	
:SBITS	1   2	
:ERRor		
:[NEXT]?		[query only]
:COUNT?		[query only]
:VERSion?		[query only]
TRIGger:		
:SOURce	INTernal   EXTernal   MANual   HOLD   IMMediate	
*CLS		[no query form]
*ESE	<numeric value>	
*ESR?		[query only]
*IDN?		[query only]
*OPC		
*SAV	0   1   2   3	[no query form]

*RCL	0   1   2   3	[no query form]
*RST		[no query form]
*SRE	<numeric value>	
*STB?		[query only]
*TST?		[query only]
*WAI		[no query form]

PERFORMANCE CHECK SHEET

Aug 99