



AVTECH ELECTROSYSTEMS LTD.

NANOSECOND WAVEFORM ELECTRONICS
SINCE 1975

□ P.O. BOX 265
OGDENSBURG, NY
U.S.A. 13669-0265
TEL: (315) 472-5270
FAX: (613) 226-2802

TEL: 1-800-265-6681
FAX: 1-800-561-1970

e-mail: info@avtechpulse.com
<http://www.avtechpulse.com>

□ P.O. BOX 5120 STN. F
OTTAWA, ONTARIO
CANADA K2C 3H4
TEL: (613) 226-5772
FAX: (613) 226-2802

INSTRUCTIONS

MODEL AV-1015-B

**0 TO ± 50 VOLTS, 1 AMP, 10 MHz
GENERAL PURPOSE LAB PULSE GENERATOR
AND LASER DIODE DRIVER
WITH IEEE 488.2 AND RS-232 CONTROL**

SERIAL NUMBER: _____

WARRANTY

Avtech Electrosystems Ltd. warrants products of its manufacture to be free from defects in material and workmanship under conditions of normal use. If, within one year after delivery to the original owner, and after prepaid return by the original owner, this Avtech product is found to be defective, Avtech shall at its option repair or replace said defective item. This warranty does not apply to units which have been disassembled, modified or subjected to conditions exceeding the applicable specifications or ratings. This warranty is the extent of the obligation assumed by Avtech with respect to this product and no other warranty or guarantee is either expressed or implied.

TECHNICAL SUPPORT

Phone: 613-226-5772 or 1-800-265-6681

Fax: 613-226-2802 or 1-800-561-1970

E-mail: info@avtechpulse.com

World Wide Web: <http://www.avtechpulse.com>

TABLE OF CONTENTS

| | |
|--|-----------|
| <i>WARRANTY</i> | 2 |
| <i>TECHNICAL SUPPORT</i> | 2 |
| <i>TABLE OF CONTENTS</i> | 3 |
| <i>INTRODUCTION</i> | 4 |
| <i>LABVIEW DRIVERS</i> | 4 |
| <i>SPECIFICATIONS</i> | 5 |
| <i>INSTALLATION</i> | 6 |
| <i>VISUAL CHECK</i> | 6 |
| <i>PLUGGING IN THE INSTRUMENT</i> | 6 |
| <i>FRONT PANEL CONTROLS</i> | 7 |
| <i>REAR PANEL CONTROLS</i> | 9 |
| <i>GENERAL INFORMATION</i> | 11 |
| <i>BASIC PULSE CONTROL</i> | 11 |
| <i>TRIGGER MODES</i> | 13 |
| <i>PULSE WIDTH MODES</i> | 13 |
| <i>GATING MODES</i> | 13 |
| <i>TOP COVER REMOVAL</i> | 14 |
| <i>ELECTROMAGNETIC INTERFERENCE</i> | 14 |
| <i>RACK MOUNTING</i> | 14 |
| <i>OPERATIONAL CHECK</i> | 15 |
| <i>PROGRAMMING YOUR PULSE GENERATOR</i> | 18 |
| <i>KEY PROGRAMMING COMMANDS</i> | 18 |
| <i>ALL PROGRAMMING COMMANDS</i> | 19 |
| <i>PERFORMANCE CHECK SHEET</i> | 21 |

INTRODUCTION

The AV-1015-B is a high performance, GPIB and RS232-equipped instrument capable of 50 W peak pulse power at repetition rates up to 10 MHz. The output amplitude is variable up to ± 50 V into 50 Ω . Pulse delay, advance and width are variable up to 10ms. Rise and fall times are fixed at less than 10 ns. The AV-1015-B provides single or double pulse output and can be triggered or gated by an external source. A front-panel pushbutton can also be used to trigger the instrument. The output pulse width can be set to follow an input trigger pulse width and the output amplitude can be controlled by an externally applied 0 to +10 Volts DC control voltage.

The AV-1015-B features front panel keyboard and adjust knob control of the output pulse parameters along with a four line by 40 character back-lit LCD display of the output amplitude, polarity, pulse width, pulse repetition frequency, source resistance and delay. The instrument includes memory to store up to four complete instrument setups. The operator may use the front panel or the computer interface to store a complete "snapshot" of all key instrument settings, and recall this setup at a later time.

The source resistance can be set at either 2 or 50 Ω . In the 2 Ω setting, the output amplitude is variable from 0.5 to 50V. In the 50 Ω setting the amplitude is variable from 0.3 to 25V to 50 Ω , or to 50 Volts to a high impedance. The output amplitude can also be controlled externally by applying a 0 to +10V DC control voltage to a rear panel BNC connector.

The MOSFET output stages will safely withstand any combination of front panel control settings, output open or short circuits, and high duty cycles. An internal power supply monitor removes the power to the output stage for five seconds if an average power overload exists. After that time, the unit operates normally for one second, and if the overload condition persists, the power is cut again. This cycle repeats until the overload is removed. With a 50 Ω load the unit will withstand duty cycles as high as 25% but with high impedance loads the duty cycle may be as high as 80%. The output stage will source up to 1 Amp (and will automatically shut down if the load current exceeds this significantly).

Application notes describing the use of the AV-1010 and AV-1015 families of pulse generators are available on the Avtech web site, <http://www.avtechpulse.com>.

LABVIEW DRIVERS

A LabVIEW driver for the AV-1015-B is available for download at <http://www.avtechpulse.com/labview>. A copy is also available in National Instruments' Instrument Driver Library at <http://www.natinst.com/>.

SPECIFICATIONS

| | |
|--|--|
| Model: | AV-1015-B |
| Pulse output amplitude ¹ : ($R_L = 50 \Omega$) | 0 to 50 Volts (for $Z_{OUT} = 2\Omega$) 0 to 25 Volts (for $Z_{OUT} = 50\Omega$) |
| Rise time, fall time: | ≤ 10 ns |
| Pulse width ² : | 20 ns to 10 ms |
| Pulse repetition rate: | 1 Hz to 10 MHz |
| GPIB control: | Included as a standard feature. |
| Maximum duty cycle: | 25% for $R_L = 50\Omega$ 80% for $R_L > 10k\Omega$ |
| Output impedance: | 2Ω or 50Ω |
| Output polarity: | Positive or negative |
| Jitter: | Pulse width: $\leq 0.1\%$, (typically $\leq 0.01\%$) Delay/Advance, Period: $\leq 0.1\%$, + 0.5 ns |
| Pulse aberrations: | $\leq \pm 5\%$ of amplitude |
| Double pulse spacing: | 100 ns to 10 ms |
| Sync delay: | 0 to ± 10 ms (between sync out and main pulse output) |
| Sync output: | + 3 Volts, 50 ns ($R_L > 1 K$) |
| Gated operation: | Has a programmable high/low synchronous/asynchronous gate |
| External trigger: | +3 to +5V, ≤ 10 MHz, PW ≥ 50 ns |
| Minimum propagation delay external trigger modes: | Advance: 140 ns Delay: 140 ns Double pulse: 140 ns PW _{IN} = PW _{OUT} : 80 ns |
| Output protection: | The output is protected against short circuits, open circuits, and high duty cycle |
| Connectors: | BNC female |
| Power source: | 120/240 Volts, $\pm 10\%$ (switchable), 48 Hz to 66 Hz |
| Dimensions (H x W x D): | 100 mm x 430 mm x 375 mm (3.9" x 17" x 14.8") |
| Weight: | ≤ 10 kg (22 lbs) |
| Chassis material: | Aluminum. Anodized aluminum front panel with cast aluminum side panels (with blue-gray plastic trim) and aluminum top and bottom panels with blue-gray plastic trim. |
| Operating temperature: | + 10° C to + 50° C |
| Accessories furnished: | one detachable 6' power cord, one operation-maintenance manual |
| Option available: | 19" rack mount kit (-R5) |

- 1) The output amplitude may also be controlled by applying 0 to +10 Volts DC to a rear panel banana connector.
- 2) The output pulse width may also be controlled externally by applying a TTL level trigger of the desired width to a rear panel banana connector (PW IN = PW OUT mode).

INSTALLATION

VISUAL CHECK

After unpacking the instrument, examine to ensure that it has not been damaged in shipment. Visually inspect all connectors, knobs, liquid crystal displays (LCDs), and the handles. Confirm that a power cord and two instrumentation manuals (this manual and the "OP1B Interface Programming Manual") are with the instrument. If the instrument has been damaged, file a claim immediately with the company that transported the instrument.

PLUGGING IN THE INSTRUMENT

Examine the rear of the instrument. There will be a male power receptacle, a fuse holder and the edge of the power selector card visible. Confirm that the power selector is in the correct orientation - it should be marked either 120 or 240, indicating whether it expects 120V AC or 240V AC. If it is not set for the proper voltage, remove the fuse and then grasp the card with a pair of pliers and remove it. Rotate horizontally through 180 degrees. Reinstall the card and the correct fuse. In the 120V setting, a 1.0A slow blow fuse is required. In the 240V setting, a 1/2A slow blow fuse is required.

FRONT PANEL CONTROLS

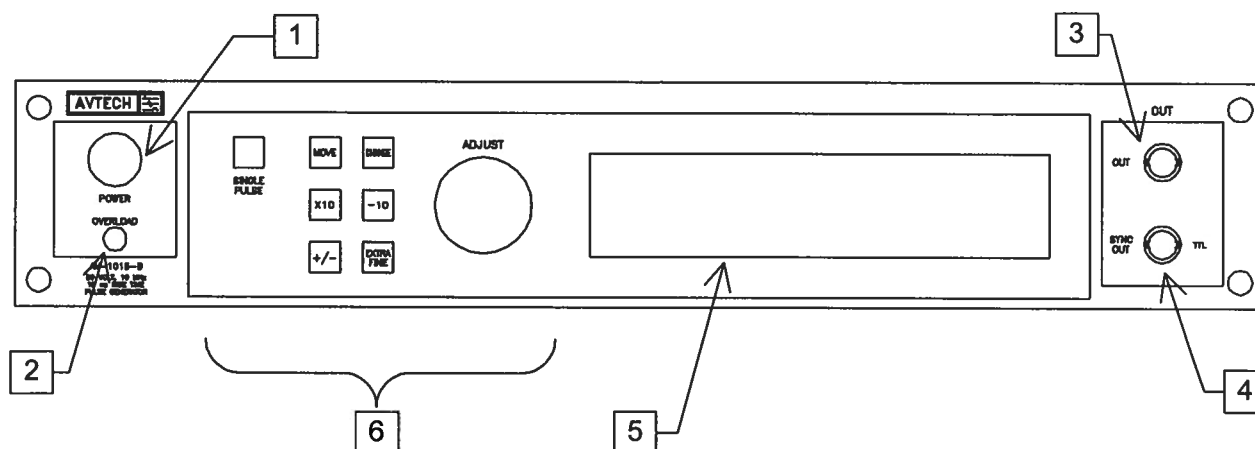

1. **POWER Switch.** The POWER push button switch applies AC prime power to the primaries of the transformer, turning the instrument on. The push button lamp (#382 type) is connected to the internal +15V DC supply.
2. **OVERLOAD.** The AV-1015-B is protected in its internal software against conflicting or dangerous settings. As an additional protective measure, an automatic overload circuit exists, which controls the front panel overload light. If the unit is overloaded (by operating at an exceedingly high duty cycle or by operating into a very low impedance), the protective circuit will turn the output of the instrument OFF and turn the indicator light ON. The light will stay ON (i.e. output OFF) for about 5 seconds after which the instrument will attempt to turn ON (i.e. light OFF) for about 1 second. If the overload condition persists, the instrument will turn OFF again (i.e. light ON) for another 5 seconds. If the overload condition has been removed, the instrument will turn on and resume normal operation.

This overload indicator is only likely to come on in two situations:

- Briefly at startup. This is not a cause for concern.
- When the instrument is set to operate into a high impedance load ($R_L > 10k\Omega$) but a low impedance load is connected instead. In this case, turn off the instrument and connect the proper load, or set the load impedance setting to the proper value.

Note that the output stage will safely withstand a short circuited load condition.

3. OUT CONNECTOR. This BNC connector provides the main output signal, into load impedances of 50Ω or higher.
4. SYNC OUT. This connector supplies a SYNC output that can be used to trigger other equipment, particularly oscilloscopes. This signal leads (or lags) the main output by a duration set by the "DELAY" controls and has an approximate amplitude of +3 Volts to $R_L > 1K$ with a pulse width of approximately 50 ns.
5. LIQUID CRYSTAL DISPLAY (LCD). This LCD is used in conjunction with the keypad to change the instrument settings. Normally, the main menu is displayed, which lists the key adjustable parameters and their current values. The "OP1B Interface Programming Manual" describes the menus and submenus in detail.
6. KEYPAD.

| Control Name | Function |
|--------------|---|
| MOVE | This moves the arrow pointer on the display. |
| CHANGE | This is used to enter the submenu, or to select the operating mode, pointed to by the arrow pointer. |
| $\times 10$ | If one of the adjustable numeric parameters is displayed, this increases the setting by a factor of ten. |
| $\div 10$ | If one of the adjustable numeric parameters is displayed, this decreases the setting by a factor of ten. |
| +/- | If one of the adjustable numeric parameters is displayed, and this parameter can be both positive or negative, this changes the sign of the parameter. |
| EXTRA FINE | This changes the step size of the ADJUST knob. In the extra-fine mode, the step size is twenty times finer than in the normal mode. This button switches between the two step sizes. |
| ADJUST | This large knob adjusts the value of any displayed numeric adjustable values, such as frequency, pulse width, etc. The adjust step size is set by the "EXTRA FINE" button. When the main menu is displayed, this knob can be used to move the arrow pointer. |

REAR PANEL CONTROLS

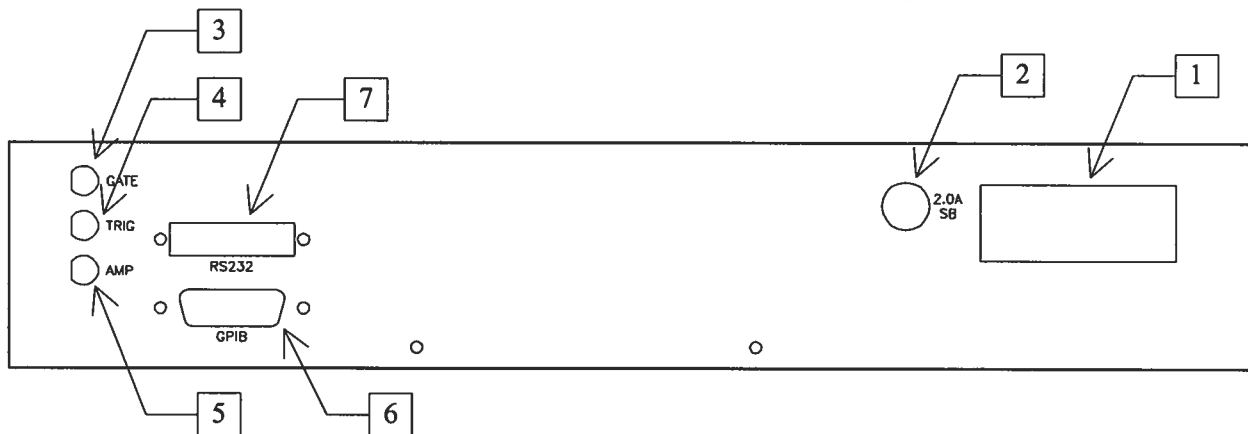

1. **AC POWER INPUT.** A three-pronged recessed male connector is provided on the back panel for AC power connection to the instrument. Also contained in this assembly is a 1.0A slow blow fuse and a removable card that can be removed and repositioned to switch between 120V AC in and 240V AC in.
2. **2.0A SB.** This fuse protects the output stage if the output duty cycle rating is exceeded.
3. **GATE.** This TTL-level (0 and +5V) logic input can be used to gate the triggering of the instrument. This input can be either active high or active low, depending on the front panel settings or programming commands. (The instrument triggers normally when this input is unconnected).
4. **TRIG.** This TTL-level (0 and +5V) logic input can be used to trigger the instrument, if the instrument is set to triggering externally. The instrument triggers on the rising edge of this input. The instrument can also be set such that the output pulse width tracks the pulse width on this input, or the output pulse width can be set independently.
5. **AMP.** The output amplitude can be set to track the DC voltage on this input. This input voltage may range between 0 and +10 Volts, which corresponds to minimum and maximum output amplitudes, respectively. (In normal operation, the output amplitude is set by the front-panel controls or via the computer interface.)
6. **GPIB Connector.** A standard GPIB cable can be attached to this connector to allow the instrument to be computer-controlled. See the "OP1B Interface Programming Manual" for more details on GPIB control.
7. **RS-232 Connector.** A standard serial cable with a 25-pin male connector can be attached to this connector to allow the instrument to be computer-controlled. See

the "OP1B Interface Programming Manual" for more details on RS-232 control.

GENERAL INFORMATION

BASIC PULSE CONTROL

This instrument can be triggered by its own internal clock or by an external TTL trigger signal. In either case, two output channels respond to the trigger: OUT and SYNC. The OUT channel is the signal that is applied to the load. Its amplitude and pulse width are variable. The SYNC pulse is a fixed-width TTL-level reference pulse used to trigger oscilloscopes or other measurement systems. When the delay is set to a positive value the SYNC pulse precedes the OUT pulse. When the delay is set to a negative value the SYNC pulse follows the OUT pulse.

These pulses are illustrated below, assuming internal triggering and a positive delay:

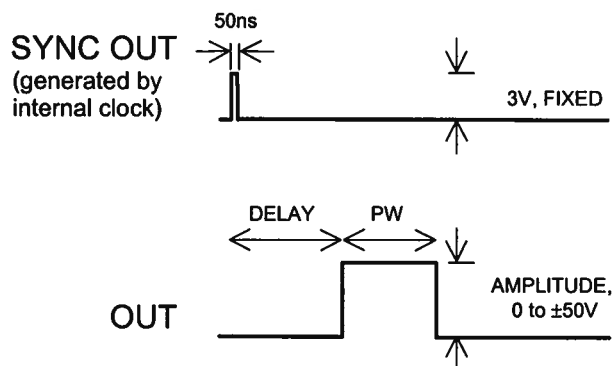

Figure A

If the delay is negative, the order of the SYNC and OUT pulses is reversed:

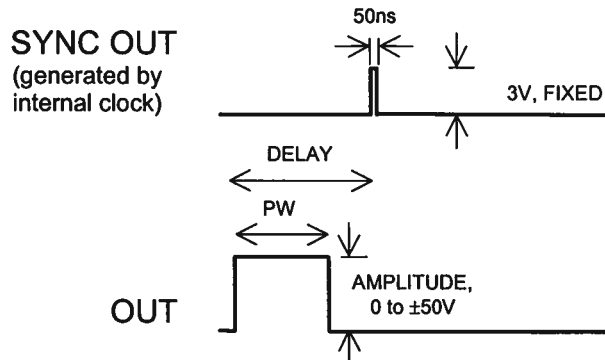

Figure B

The next figure illustrates the relationship between the signal when an external TTL-level trigger is used:

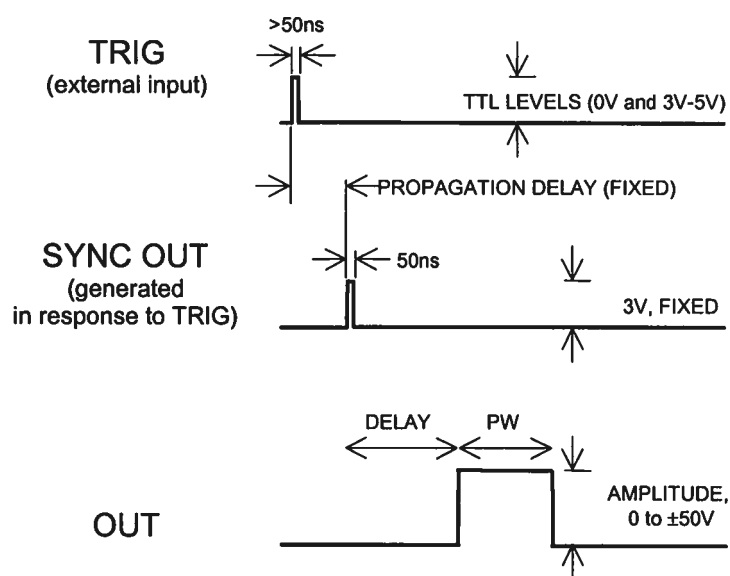

Figure C

As before, if the delay is negative, the order of the SYNC and OUT pulses is reversed.

The last figure illustrates the relationship between the signal when an external TTL-level trigger is used in the $PW_{\text{IN}}=PW_{\text{OUT}}$ mode. In this case, the output pulse width equals the external trigger's pulse width (approximately), and the delay circuit is bypassed:

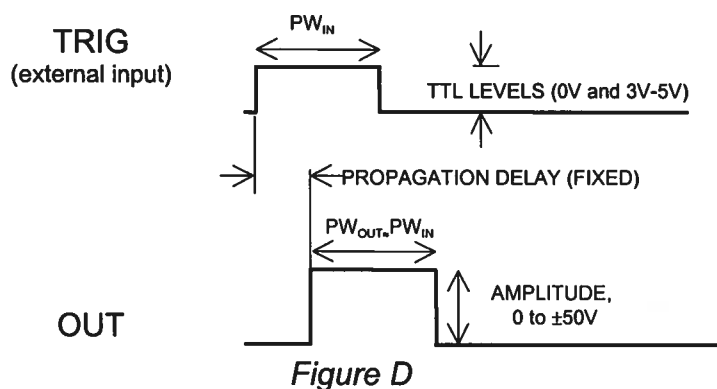

Figure D

The delay, pulse width, and frequency (when in the internal mode), of the OUT pulse can be varied with front panel controls or via the GPIB or RS-232 computer interfaces.

TRIGGER MODES

This instrument has four trigger modes:

- **Internal Trigger:** the instrument controls the trigger frequency, and generates the clock internally.
- **External Trigger:** the instrument is triggered by an external TTL-level clock on the back-panel TRIG connector.
- **Manual Trigger:** the instrument is triggered by the front-panel “SINGLE PULSE” pushbutton.
- **Hold Trigger:** the instrument is set to not trigger at all.

These modes can be selected using the front panel trigger menu, or by using the appropriate programming commands. (See the “OP1B Interface Programming Manual” for more details.)

PULSE WIDTH MODES

This instrument has two pulse width modes:

- **Normal:** the instrument controls the output pulse width.
- **$PW_{IN}=PW_{OUT}$:** the output pulse width equals the pulse width of the trigger signal on the “TRIG” connector. The instrument must be in the external trigger mode.

These modes can be selected using the front panel pulse width menu, or by using the appropriate programming commands. (See the “OP1B Interface Programming Manual” for more details.)

GATING MODES

Triggering can be suppressed by a TTL-level signal on the rear-panel GATE connector. The instrument can be set to stop triggering when this input high or low, using the front-panel gate menu or the appropriate programming commands. This input can also be set to act synchronously or asynchronously. When set to asynchronous mode, the GATE will disable the output immediately. Output pulses may be truncated. When set to synchronous mode, the output will complete the full pulse width if the output is high, and then stop triggering. No pulses are truncated in this mode.

TOP COVER REMOVAL

The interior of the instrument may be accessed by removing the four Phillips screws on the top panel. With the four screws removed, the top cover may be slid back (and off).

ELECTROMAGNETIC INTERFERENCE

To prevent electromagnetic interference with other equipment, all used outputs should be connected to shielded 50Ω loads using shielded 50Ω coaxial cables. Unused outputs should be terminated with shielded 50Ω BNC terminators or with shielded BNC dust caps, to prevent unintentional electromagnetic radiation. All cords and cables should be less than 3m in length.

RACK MOUNTING

A rack mounting kit is available. The -R5 rack mount kit may be installed after first removing the one Phillips screw on the side panel adjacent to the front handle.

OPERATIONAL CHECK

This section describes a sequence to confirm the basic operation of the instrument. It should be performed after receiving the instrument. It is a useful learning exercise as well.

Before proceeding with this procedure, finish reading this instruction manual thoroughly. Then read the "Local Control" section of the "OP1B Interface Programming Manual" thoroughly. The "Local Control" section describes the front panel controls used in this operational check - in particular, the MOVE, CHANGE, and ADJUST controls.

1. Connect a cable from the SYNC OUT connector to the TRIG input of an oscilloscope. Connect a 15W (or higher), low-inductance, 50 Ω load to the OUT connector and place the scope probe across this load. Set the oscilloscope to trigger externally with the vertical setting at 5 Volts/div and the horizontal setting at 1 μ s/div.
2. Turn on the AV-1015-B. The main menu will appear on the LCD.
3. To set the AV-1015-B to trigger from the internal clock at a PRF of 10 kHz:
 - a) The arrow pointer should be pointing at the frequency menu item. If it is not, press the MOVE button until it is.
 - b) Press the CHANGE button. The frequency submenu will appear. Rotate the ADJUST knob until the frequency is set at 10 kHz.
 - c) The arrow pointer should be pointing at the "Internal" choice. If it is not, press MOVE until it is.
 - d) Press CHANGE to return to the main menu.
4. To set the delay to 1 μ s:
 - a) Press the MOVE button until the arrow pointer is pointing at the delay menu item.
 - b) Press the CHANGE button. The delay submenu will appear. Rotate the ADJUST knob until the delay is set at 1 μ s.
 - c) The arrow pointer should be pointing at the "Normal" choice. If it is not, press MOVE until it is.

- d) Press CHANGE to return to the main menu.
5. To set the pulse width to 1 μs :
 - a) Press the MOVE button until the arrow pointer is pointing at the pulse width menu item.
 - b) Press the CHANGE button. The pulse width submenu will appear. Rotate the ADJUST knob until the pulse width is set at 1 μs .
 - c) The arrow pointer should be pointing at the "Normal" choice. If it is not, press MOVE until it is.
 - d) Press CHANGE to return to the main menu.
 6. The main menu display should show that the output impedance (Z_{OUT}) is set at 2Ω , and the load impedance (R_L) is set at 50Ω . If they are different, change the settings.
 7. At this point, nothing should appear on the oscilloscope.
 8. To enable the output:
 - a) Press the MOVE button until the arrow pointer is pointing at the output menu item.
 - b) Press the CHANGE button. The output submenu will appear.
 - c) Press MOVE until the arrow pointer is pointing at the "ON" choice.
 - d) Press CHANGE to return to the main menu.
 9. To change the output amplitude:
 - a) Press the MOVE button until the arrow pointer is pointing at the amplitude menu item.
 - b) Press the CHANGE button. The amplitude submenu will appear. Rotate the ADJUST knob until the amplitude is set at 10V.
 - c) Observe the oscilloscope. You should see 1 μs wide, 10V pulses.
 - d) Rotate the ADJUST knob. The amplitude as seen on the oscilloscope should vary. Set it at 20V.
 - e) Press CHANGE to return to the main menu.

10. Try varying the pulse width, by repeating step (6). As you rotate the ADJUST knob, the pulse width on the oscilloscope will change. It should agree with the displayed value. Stay below 25% duty cycle.
11. Go to the output impedance menu, and set the output impedance (Z_{OUT}) to $50\ \Omega$. Return to the main menu. If a $50\ \Omega$ load is attached to the output (see step 1) the amplitude should fall by a factor of 2, to 10V.
12. To change the output amplitude polarity:
 - a) Press the MOVE button until the arrow pointer is pointing at the amplitude menu item.
 - b) Press the CHANGE button. The amplitude submenu will appear.
 - c) Press the "+/-" button. The amplitude as seen on the oscilloscope should become negative.
 - d) Press CHANGE to return to the main menu.

This completes the operational check.

PROGRAMMING YOUR PULSE GENERATOR

KEY PROGRAMMING COMMANDS

The "OP1B Interface Programming Manual" describes in detail how to connect the pulse generator to your computer, and the programming commands themselves. A large number of commands are available; however, normally you will only need a few of these. Here is a basic sample sequence of commands that might be sent to the instrument after power-up:

| | |
|-------------------------|---|
| *rst | (resets the instrument) |
| trigger:source internal | (selects internal triggering) |
| frequency 1000 Hz | (sets the frequency to 1000 Hz) |
| pulse:width 10 us | (sets the pulse width to 10 us) |
| pulse:delay 1 us | (sets the delay to 1 us) |
| output:load 50 | (tells the instrument that you are using a 50 Ω load. This affects the duty cycle limit. The only other allowed setting is output:load 10000.) |
| output:impedance 2 | (sets the output impedance to 2 Ω . The only other allowed setting is output:impedance 50.) |
| volt 50 | (sets the amplitude to 50 V) |
| output on | (turns on the output) |

For triggering a single event, this sequence would be more appropriate:

| | |
|--------------------------|---|
| *rst | (resets the instrument) |
| trigger:source hold | (turns off all triggering) |
| pulse:width 50 ns | (sets the pulse width to 50 ns) |
| output:load 50 | (tells the instrument that you are using a 50 Ω load.) |
| output:impedance 2 | (sets the output impedance to 2 Ω .) |
| output on | (turns on the output) |
| volt:ampl -50 | (sets the amplitude to -50 V) |
| trigger:source immediate | (generates a single non-repetitive trigger event) |
| trigger:source hold | (turns off all triggering) |
| output off | (turns off the output) |

To set the instrument to trigger from an external TTL signal applied to the rear-panel TRIG connector, use:

| | |
|-------------------------|---|
| *rst | (resets the instrument) |
| trigger:source external | (selects internal triggering) |
| output:load 50 | (tells the instrument that you are using a 50Ω load.) |
| output:impedance 2 | (sets the output impedance to 2Ω.) |
| pulse:width 50 ns | (sets the pulse width to 50 ns) |
| pulse:delay 1 us | (sets the delay to 1 us) |
| volt:ampl -25V | (sets the amplitude to -25 V) |
| output on | (turns on the output) |

These commands will satisfy 90% of your programming needs.

ALL PROGRAMMING COMMANDS

For more advanced programmers, a complete list of the available commands is given below. These commands are described in detail in the “OP1B Interface Programming Manual”. (Note: this manual also includes some commands that are not implemented in this instrument. They can be ignored.)

| <u>Keyword</u> | <u>Parameter</u> | <u>Notes</u> |
|----------------|----------------------------|--------------|
| LOCAL | | |
| OUTPut: | | |
| :LOAD | 50 10000 | |
| :[STATE] | <boolean value> | |
| :IMPedance | <numeric value> | |
| :PROTection | | |
| :TRIPped? | | [query only] |
| REMOTE | | |
| [SOURce]: | | |
| :FREQuency | | |
| [:CW FIXed] | <numeric value> | |
| [SOURce]: | | |
| :PULSe | | |
| :PERiod | <numeric value> | |
| :WIDTh | <numeric value> EXTernal | |
| :DCYClE | <numeric value> | |
| :HOLD | WIDTh DCYClE | |
| :DELay | <numeric value> | |
| :DOUBle | | |
| [:STATE] | <boolean value> | |
| :DELay | <numeric value> | |
| :GATE | | |
| :TYPE | ASYNc SYNc | |
| :LEVel | High Low | |
| [SOURce]: | | |
| :VOLTage | | |
| [:LEVel] | | |
| [:IMMEdiate] | | |
| [:AMPLitude] | <numeric value> EXTernal | |
| :PROTection | | |

| | | |
|---------------|---|----------------------------------|
| :TRIPped? | | [query only] |
| STATUS: | | |
| :OPERation | | |
| :[EVENT]? | | [query only, always returns "0"] |
| :CONDition? | | [query only, always returns "0"] |
| :ENABle | <numeric value> | [implemented but not useful] |
| :QUEStionable | | |
| :[EVENT]? | | [query only, always returns "0"] |
| :CONDition? | | [query only, always returns "0"] |
| :ENABle | <numeric value> | [implemented but not useful] |
| SYSTEM: | | |
| :COMMunicate | | |
| :GPIB | | |
| :ADDRess | <numeric value> | |
| :SERial | | |
| :CONTrol | | |
| :RTS | ON IBFull RFR | |
| :[RECeive] | | |
| :BAUD | 1200 2400 4800 9600 | |
| :BITS | 7 8 | |
| :ECHO | <boolean value> | |
| :PARity | | |
| :[TYPE] | EVEN ODD NONE | |
| :SBITS | 1 2 | |
| :ERRor | | |
| :[NEXT]? | | [query only] |
| :COUNT? | | [query only] |
| :VERSion? | | [query only] |
| TRIGger: | | |
| :SOURce | INTernal EXTernal MANual HOLD IMMEDIATE | |
| *CLS | | [no query form] |
| *ESE | <numeric value> | |
| *ESR? | | [query only] |
| *IDN? | | [query only] |
| *OPC | | |
| *SAV | 0 1 2 3 | [no query form] |
| *RCL | 0 1 2 3 | [no query form] |
| *RST | | [no query form] |
| *SRE | <numeric value> | |
| *STB? | | [query only] |
| *TST? | | [query only] |
| *WAI | | [no query form] |

PERFORMANCE CHECK SHEET

Edition 2 created by MJC - May 28/99