



**AVTECH ELECTROSYSTEMS LTD.**

NANOSECOND WAVEFORM ELECTRONICS  
SINCE 1975

P.O. BOX 265  
OGDENSBURG, NY  
U.S.A. 13669-0265  
TEL: (315) 472-5270  
FAX: (613) 226-2802

TEL: 1-800-265-6681  
FAX: 1-800-561-1970

e-mail: [info@avtechpulse.com](mailto:info@avtechpulse.com)  
<http://www.avtechpulse.com>

P.O. BOX 5120 STN. F  
OTTAWA, ONTARIO  
CANADA K2C 3H4  
TEL: (613) 226-5772  
FAX: (613) 226-2802

**INSTRUCTIONS**

**MODEL AV-108A-3-B**

**0 to 200 AMP, 0 to 20 V, 5  $\mu$ s RISE TIME  
LASER DIODE DRIVER  
WITH IEEE 488.2 AND RS-232 CONTROL**

**SERIAL NUMBER: \_\_\_\_\_**

### WARRANTY

Avtech Electrosystems Ltd. warrants products of its manufacture to be free from defects in material and workmanship under conditions of normal use. If, within one year after delivery to the original owner, and after prepaid return by the original owner, this Avtech product is found to be defective, Avtech shall at its option repair or replace said defective item. This warranty does not apply to units which have been disassembled, modified or subjected to conditions exceeding the applicable specifications or ratings. This warranty is the extent of the obligation assumed by Avtech with respect to this product and no other warranty or guarantee is either expressed or implied.

### TECHNICAL SUPPORT

Phone: 613-226-5772 or 1-800-265-6681

Fax: 613-226-2802 or 1-800-561-1970

E-mail: [info@avtechpulse.com](mailto:info@avtechpulse.com)

World Wide Web: <http://www.avtechpulse.com>

## TABLE OF CONTENTS

<b><i>WARRANTY</i></b>	<b>2</b>
<b><i>TECHNICAL SUPPORT</i></b>	<b>2</b>
<b><i>TABLE OF CONTENTS</i></b>	<b>3</b>
<b><i>INTRODUCTION</i></b>	<b>5</b>
<b><i>SPECIFICATIONS</i></b>	<b>7</b>
<b><i>INSTALLATION</i></b>	<b>8</b>
<b><i>VISUAL CHECK</i></b>	<b>8</b>
<b><i>PLUGGING IN THE INSTRUMENT</i></b>	<b>8</b>
<b><i>MAINFRAME FRONT PANEL CONTROLS</i></b>	<b>9</b>
<b><i>MAINFRAME REAR PANEL CONTROLS</i></b>	<b>11</b>
<b><i>OUTPUT MODULE CONTROLS AND CONNECTORS</i></b>	<b>12</b>
<b><i>OUTPUT MODULE CONTROLS AND CONNECTORS</i></b>	<b>12</b>
<b><i>Outputs</i></b>	<b>12</b>
<b><i>Dual Polarity Connections</i></b>	<b>13</b>
<b><i>P1-P5 Controls</i></b>	<b>13</b>
<b><i>GENERAL INFORMATION</i></b>	<b>14</b>
<b><i>BASIC TEST ARRANGEMENT</i></b>	<b>14</b>
<b><i>CURRENT MEASUREMENT</i></b>	<b>15</b>
<b><i>BASIC PULSE CONTROL</i></b>	<b>15</b>
<b><i>TRIGGER MODES</i></b>	<b>17</b>
<b><i>PULSE WIDTH MODES</i></b>	<b>17</b>
<b><i>GATING MODES</i></b>	<b>18</b>
<b><i>TOP COVER REMOVAL</i></b>	<b>18</b>
<b><i>RACK MOUNTING</i></b>	<b>18</b>
<b><i>MONITOR CIRCUIT</i></b>	<b>18</b>
<b><i>LOAD PROTECTION</i></b>	<b>19</b>
<b><i>LENZ'S LAW AND INDUCTIVE VOLTAGE SPIKES</i></b>	<b>19</b>
<b><i>ATTACHING AND DETACHING LOADS</i></b>	<b>19</b>
<b><i>CHANGING PARAMETERS WHEN A LOAD IS ATTACHED</i></b>	<b>20</b>
<b><i>START-UP CHECK-LIST FOR LOCAL CONTROL</i></b>	<b>21</b>

<b><i>CALIBRATION ADJUSTMENTS</i></b>	<b>23</b>
<b><i>ADJUSTING AMPLITUDE ACCURACY</i></b>	<b>23</b>
<b><i>OTHER CALIBRATION PROCEDURES</i></b>	<b>23</b>
<b><i>PROGRAMMING YOUR PULSE GENERATOR</i></b>	<b>24</b>
<b><i>KEY PROGRAMMING COMMANDS</i></b>	<b>24</b>
<b><i>ALL PROGRAMMING COMMANDS</i></b>	<b>25</b>
<b><i>PERFORMANCE CHECK SHEET</i></b>	<b>27</b>

## INTRODUCTION

The Model AV-108A-3-B pulse generator is designed for pulsing laser diode and other low impedance loads with rectangular pulses as high as 200 Amperes into load voltages up to 20V, with 5  $\mu$ s rise and fall times.

The current and voltage polarities depend on the model number:

"-P" units: 0 to +200 A amplitude, 0 to +20 V compliance

"-N" units: 0 to -200 A amplitude, 0 to -20 V compliance

"-PN" units: 0 to +200 A amplitude, 0 to +20 V compliance  
and  
0 to -200 A amplitude, 0 to -20 V compliance

The pulse repetition frequency can vary from 1 to 1000 Hz, and pulse widths can vary from 10  $\mu$ s to 1 ms. The maximum duty cycle is 1%.

The Model AV-108A-3-B pulse generator is a current pulser. The current amplitude is largely independent of the load voltage. The load voltage must not exceed 20V.

The AV-108A-3-B system consists of an instrument mainframe and a negative output module (the AV-108A-3-B-PG). The output module connects to the mainframe using two cables: a 25-conductor cable, detachable at the mainframe end, carries the control signals, and a single-conductor shielded RG-58 cable, detachable at both ends, carries the "high voltage" power supply ( $\pm 24$ V, approximately).

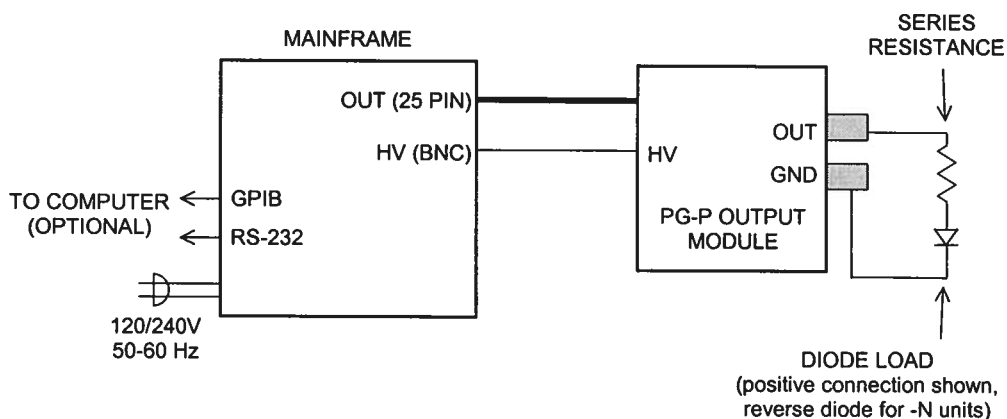

The loads can be connected across the banana posts on the output module.

-PN units have two output modules, one for each polarity. Only one module is active at a time.

The AV-108A-3-B can be controlled from the front panel, or via a computer connected to the IEEE 488.2-compliant GPIB port, or the RS-232 serial port.

## SPECIFICATIONS

Model:	AV-108A-3-B
GPIB, RS-232 control:	Standard on -B units.
Amplitude:	
-P units:	0 to +200A.
-N units:	0 to -200A.
-PN units:	0 to $\pm$ 200A.
Pulse width:	10 to 1000 $\mu$ s
Rise time, fall time:	$\leq$ 5 $\mu$ s
PRF:	1 Hz to 1000 Hz
Duty cycle: (max)	1%
Current regulation:	Load voltage change from 0 to 20 Volts: $\leq$ 5%
Load voltage range:	
-P units:	0 to +20 Volts.
-N units:	0 to -20 Volts.
-PN units:	0 to +20 Volts for positive output, 0 to -20 Volts for negative output.
Propagation delay, (Jitter):	$\leq$ 1 $\mu$ s, ( $\pm$ 100 ps $\pm$ 0.03% of sync delay, Ext trig in to pulse out)
Ext. trigger in:	Mode A: + 5 Volts, 50 ns or wider (TTL), Mode B: + 5 Volts, PW <sub>IN</sub> = PW <sub>OUT</sub> (TTL)
Sync delay: (sync to pulse out)	0 to $\pm$ 1000 $\mu$ s
Sync output:	+ 3 Volt, 200 ns, will drive 50 Ohm loads
Gate input:	Synchronous or asynchronous, active high or low, switchable. Suppresses triggering when active.
Connectors:	Out: Banana Posts      Trig: BNC      Sync: BNC Gate: BNC      HV: BNC
Power requirements:	120/240 Volts (switchable) 50 - 60 Hz
Dimensions:	Mainframe: 100 x 215 x 375 mm (3.9" x 8.5" x 14.8") Output module: 152 x 152 x 229 mm (6" x 9" x 12")
Temperature range:	+ 10° to + 40° C

## INSTALLATION

### VISUAL CHECK

After unpacking the instrument mainframe and the two output modules, examine to ensure that they have not been damaged in shipment. Visually inspect all connectors, knobs, liquid crystal displays (LCDs), and the handles. Confirm that a power cord and two instrumentation manuals (this manual and the "OP1B Interface Programming Manual") are with the instrument. If the instrument has been damaged, file a claim immediately with the company that transported the instrument.

### PLUGGING IN THE INSTRUMENT

Examine the rear of the instrument. There will be a male power receptacle, a fuse holder and the edge of the power selector card visible. Confirm that the power selector is in the correct orientation - it should be marked either 120 or 240, indicating whether it expects 120V AC or 240V AC. If it is not set for the proper voltage, remove the fuse and then grasp the card with a pair of pliers and remove it. Rotate horizontally through 180 degrees. Reinstall the card and the correct fuse. In the 120V setting, a 1.5A slow blow fuse is required. In the 240V setting, a 0.75A slow blow fuse is required.



## MAINFRAME FRONT PANEL CONTROLS

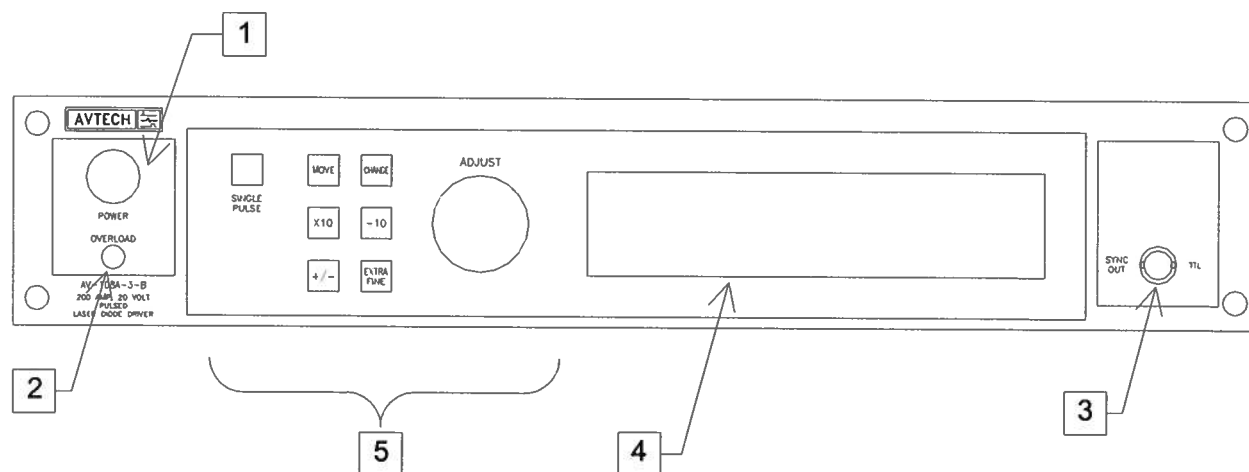

1. **POWER Switch**. The POWER push button switch applies AC prime power to the primaries of the transformer, turning the instrument on. The push button lamp (#382 type) is connected to the +15V DC supply.
2. **OVERLOAD**. A protective circuit controls the front panel overload light. This indicator will light if the output module is overheating. (An audible buzzer will also sound, and the trigger will be disabled.) This may occur at high duty cycles when driving a low-impedance load. See the "High Duty Cycle Operation" section for methods of avoiding overheating.
3. **SYNC OUT**. This connector supplies a SYNC output that can be used to trigger other equipment, particularly oscilloscopes. This signal leads, or lags, the main output by a duration set by the "DELAY" controls and has an approximate amplitude of +3 Volts to  $R_L > 1k\Omega$  with a pulse width of approximately 200 ns.
4. **LIQUID CRYSTAL DISPLAY (LCD)**. This LCD is used in conjunction with the keypad to change the instrument settings. Normally, the main menu is displayed, which lists the key adjustable parameters and their current values. The "OP1B Interface Programming Manual" describes the menus and submenus in detail.

5. KEYPAD.

Control Name	Function
MOVE	This moves the arrow pointer on the display.
CHANGE	This is used to enter the submenu, or to select the operating mode, pointed to by the arrow pointer.
×10	If one of the adjustable numeric parameters is displayed, this increases the setting by a factor of ten.
÷10	If one of the adjustable numeric parameters is displayed, this decreases the setting by a factor of ten.
+/-	If one of the adjustable numeric parameters is displayed, and this parameter can be both positive or negative, this changes the sign of the parameter.
EXTRA FINE	This changes the step size of the ADJUST knob. In the extra-fine mode, the step size is twenty times finer than in the normal mode. This button switches between the two step sizes.
ADJUST	This large knob adjusts the value of any displayed numeric adjustable values, such as frequency, pulse width, etc. The adjust step size is set by the "EXTRA FINE" button.  When the main menu is displayed, this knob can be used to move the arrow pointer.

## MAINFRAME REAR PANEL CONTROLS

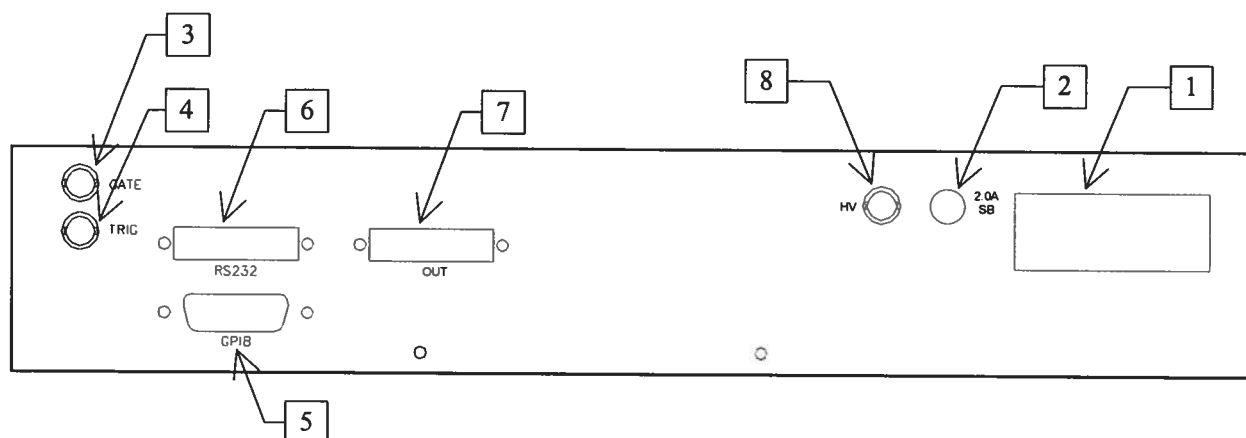

1. **AC POWER INPUT.** A three-pronged recessed male connector is provided on the back panel for AC power connection to the instrument. Also contained in this assembly is a 1.5A slow blow fuse and a removable card that can be removed and repositioned to switch between 120V AC in and 240V AC in.
2. **DC FUSE.** This 2.0A slow-blow fuse protects the internal DC power supply.
3. **GATE.** This TTL-level (0 and +5V) logic input can be used to gate the triggering of the instrument. This input can be either active high or active low, depending on the front panel settings or programming commands. (The instrument triggers normally when this input is unconnected).
4. **TRIG.** This TTL-level (0 and +5V) logic input can be used to trigger the instrument, if the instrument is set to triggering externally. The instrument triggers on the rising edge of this input.
5. **GPIB Connector.** A standard GPIB cable can be attached to this connector to allow the instrument to be computer-controlled. See the "OP1B Interface Programming Manual" for more details on GPIB control.
6. **RS-232 Connector.** A standard serial cable with a 25-pin male connector can be attached to this connector to allow the instrument to be computer-controlled. See the "OP1B Interface Programming Manual" for more details on RS-232 control.
7. **OUT.** The 25-pin cable from the output module is connected to this connector. "-PN" units will have two OUT connectors, one for each module.
8. **HV BNC Connector.** The shielded RG-58 cable from the output module is connected to this connector. This carries the high-voltage power supply (either +24V or -24V, depending on the output polarity) to the output module.

## OUTPUT MODULE CONTROLS AND CONNECTORS

### Outputs

The main output on the output module is a red banana post. A black banana post serves as a ground connection.

A typical connection scheme is shown below for positive output modules, supplied with “-P” and “-PN” units:

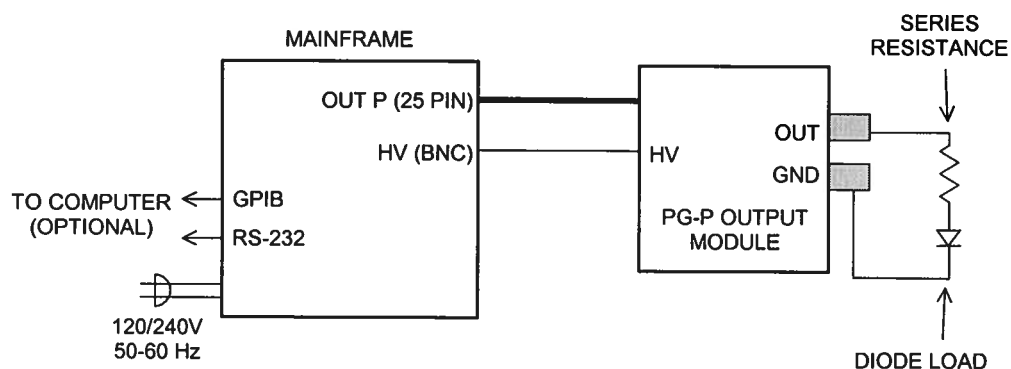

A typical connection scheme is shown below for negative output modules, supplied with “-N” and “-PN” units:

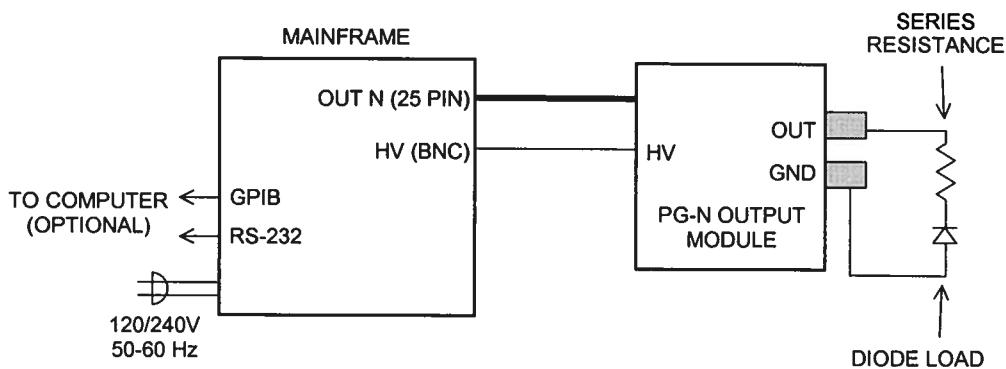

Both of these figures show a resistance in series with the laser diode. Since the AV-108A-3-B is a current pulser, this resistance is optional - it is not required for current limiting.

The load should be connected between the OUT and GND terminals using very short leads (< 0.5 cm).

### Dual Polarity Connections

“-PN” units are supplied with two output modules. Only one is active at a time.

The mainframe on “-PN” unit has both “OUT P” and “OUT N” connectors on the rear panel. The PG-P module should be connected to the “OUT P” connector, and the PG-N module should be connected to the “OUT N” connector.

Only one “HV” connector is present on the rear-panel. It must be connected to the PG-P module when operating in positive polarity mode, and to the PG-N module when operating in negative polarity mode.

### P1-P5 Controls

The P1 and P4 ten-turn trim-pots (on the -PG module) may be used to limit the peak output current to less than 200 Amps. Rotating P1 counter-clockwise will cause the peak output current to be less than 200 Amps when the amplitude is set at maximum. The amplitude settings will still be active (basically linear) over the full range of 0 to 200 Amps. Rotating P4 counter-clockwise will cause the output to abruptly limit at less than 200 Amps. The amplitude control will be initially linear and then at the limiting point will become inactive. At the time of shipping, both P1 and P4 were set to provide linear, 200 Ampere operation. CAUTION: The P2, P3 and P5 controls are for factory adjustment only. The warranty may become invalid if these 3 controls are adjusted.

## GENERAL INFORMATION

### BASIC TEST ARRANGEMENT

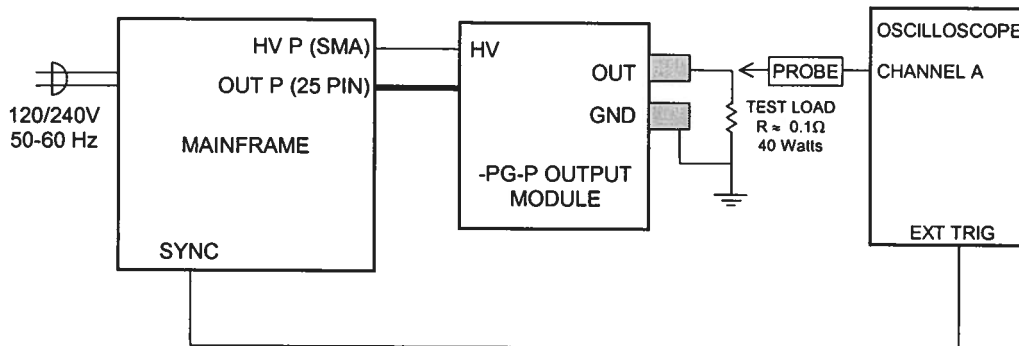

The equipment should be connected in the general fashion shown above.

Output modules should always be connected to the mainframe **BEFORE** power is applied.

Proper choice of test resistance is important. It is essential that the resistive test load be low-inductance. (Wirewound resistors are not acceptable, unless many are connected together in parallel.) The power dissipated in the resistor is given by

$$P_{\text{AVERAGE}} = I^2 \times R \times \frac{PW}{T}, \quad P_{\text{PEAK}} = I^2 \times R$$

where "I" is the current, "R" is the resistance, "PW" is the pulse width, and "T" is the pulse period (1/frequency).

The power rating of the resistance should exceed this average power rating by a large margin. Beware that some low-value resistors exhibit a significant temperature-dependence, even when the average power dissipated is below the resistor's power rating. This is particularly true if the peak power exceeds the resistor's power rating.

Factory tests are conducted with a 0.1 Ω load capable of dissipating at least 40 W. Higher load resistance values may be used but the output voltage must be limited to 20V or less.

## CURRENT MEASUREMENT

Measuring current is more difficult than measuring voltage. There are three basic approaches to measuring pulsed current:

1. Rely on the accuracy of the amplitude setting (typically 5%), as displayed on the LCD display.
2. Use a high-performance current transformer, such as a Pearson 410 or Pearson 101 (<http://www.pearsonelectronics.com/>). The Pearson 410 is preferred since it is physically smaller than the 101, and requires a shorter lead length. This reduces the added inductance in the load circuit, and thus minimizes inductive waveform distortions. (See the "Load Protection" section for more information on inductive distortions.)
3. Use a low-resistance, low-inductance, current-sensing resistor connected in series with the load. To minimize inductance, it is usually wise to connect several resistors in parallel. Beware that wirewound resistors usually have far too much inductance to be useful as current-sensing resistors.

## BASIC PULSE CONTROL

This instrument can be triggered by its own internal clock or by an external TTL trigger signal. In either case, two output channels respond to the trigger: OUT and SYNC. The OUT channel is the signal that is applied to the device under test. Its amplitude and pulse width are variable. The SYNC pulse is a fixed-width TTL-level reference pulse used to trigger oscilloscopes or other measurement systems. When the delay is set to a positive value the SYNC pulse precedes the OUT pulse.

These pulses are illustrated below, assuming internal triggering and a positive delay:

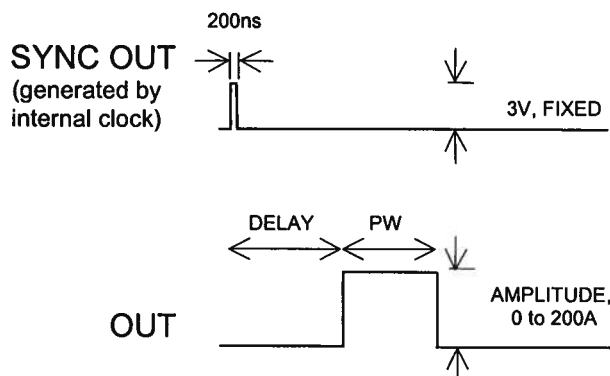

*Figure A*

If the delay is negative, the order of the SYNC and OUT pulses is reversed:

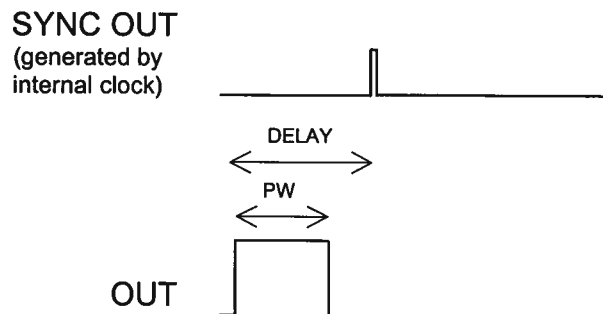

Figure B

The next figure illustrates the relationship between the signal when an external TTL-level trigger is used:

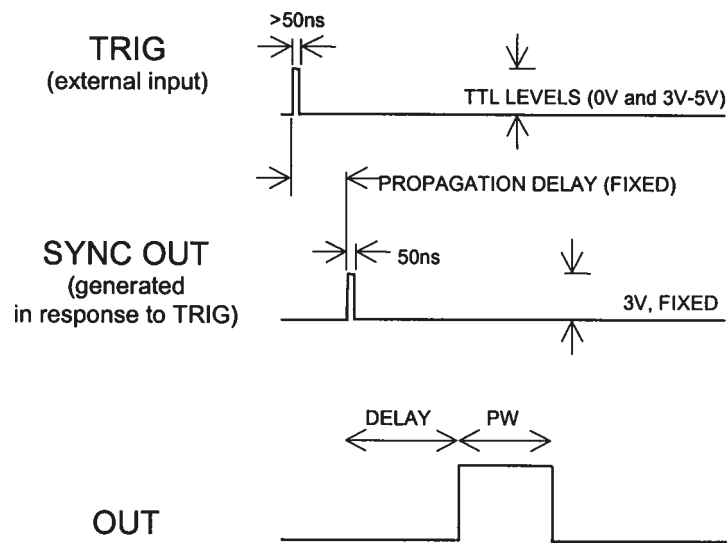
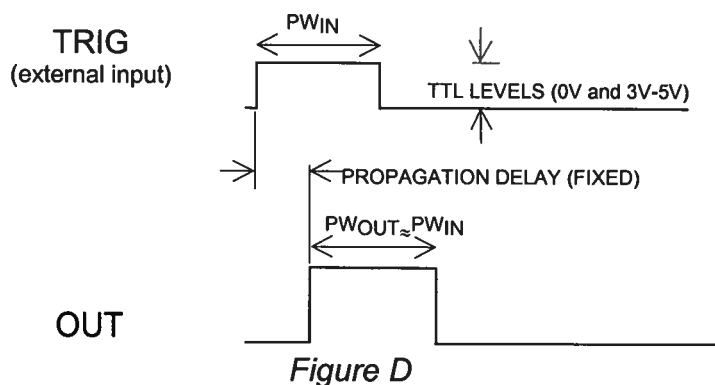

Figure C

As before, if the delay is negative, the order of the SYNC and OUT pulses is reversed.

The last figure illustrates the relationship between the signal when an external TTL-level trigger is used in the  $PW_{IN}=PW_{OUT}$  mode. In this case, the output pulse width equals the external trigger's pulse width (approximately), and the delay circuit is bypassed:





The delay, pulse width, and frequency (when in the internal mode), of the OUT pulse can be varied with front panel controls or via the GPIB or RS-232 computer interfaces.

### TRIGGER MODES

This instrument has four trigger modes:

- Internal Trigger: the instrument controls the trigger frequency, and generates the clock internally.
- External Trigger: the instrument is triggered by an external TTL-level clock on the back-panel TRIG connector.
- Manual Trigger: the instrument is triggered by the front-panel "SINGLE PULSE" pushbutton.
- Hold Trigger: the instrument is set to not trigger at all.

These modes can be selected using the front panel trigger menu, or by using the appropriate programming commands. (See the "OP1B Interface Programming Manual" for more details.)

### PULSE WIDTH MODES

This instrument has two pulse width modes:

- Normal: the instrument controls the output pulse width.
- $PW_{IN}=PW_{OUT}$ : the output pulse width equals the pulse width of the trigger signal on the "TRIG" connector. The instrument must be in the external trigger mode.

These modes can be selected using the front panel pulse width menu, or by using the appropriate programming commands. (See the "OP1B Interface Programming Manual" for more details.)

### GATING MODES

Triggering can be suppressed by a TTL-level signal on the rear-panel GATE connector. The instrument can be set to stop triggering when this input high or low, using the front-panel gate menu or the appropriate programming commands. This input can also be set to act synchronously or asynchronously. When set to asynchronous mode, the GATE will disable the output immediately. Output pulses may be truncated. When set to synchronous mode, the output will complete the full pulse width if the output is high, and then stop triggering. No pulses are truncated in this mode.

### TOP COVER REMOVAL

The top cover of the instrument may be removed by removing the four Phillips screws on the top panel. With these four screws removed, the top panel may be slid off by pulling it towards the rear.

### RACK MOUNTING

A rack mounting kit is available. The -R5 rack mount kit may be installed after first removing the one Phillips screw on the side panel adjacent to the front handle.

### MONITOR CIRCUIT

All units include a rear-panel current monitor output. This output generates a voltage waveform approximately proportional to the output current waveform, according to:

$$V_{\text{MON}} \approx I_{\text{OUT}} \times 1\text{V}/100\text{A}$$

## LOAD PROTECTION

### LENZ'S LAW AND INDUCTIVE VOLTAGE SPIKES

This instrument is designed to pulse resistive and diode loads and will exhibit a large output spike when used to drive a load with significant inductance (as predicted by LENZ'S LAW). For this reason the load should be connected to the output using low inductance leads (as short as possible and as heavy a gauge as possible).

The voltage developed across an inductance L (in Henries), when the current is changing at a rate given by  $di_{LOAD}/dt$  (in Amps/sec), is:  $V_{SPIKE} = L \frac{di_{LOAD}}{dt}$ .

Some load inductance is unavoidable. As a result, the output voltage waveform (measured across a resistance) will have some distortion on the leading edge, as shown:

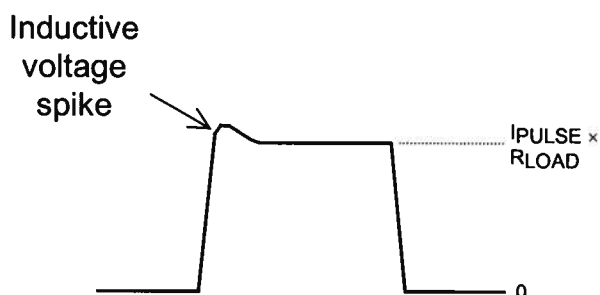

Attaching a current transformer (for measuring current waveforms) can add significant inductance, because of the necessary wire length that must be fed through the transformer. The Pearson 2878 requires approximately 1.5", and the 410 requires 3". Both will degrade the output current rise time.

### ATTACHING AND DETACHING LOADS

To avoid damaging the loads connected to main outputs, the loads should only be connected to or removed from the instrument when the instrument is off. Do not connect loads when the instrument is on and the output amplitude is not zero. This can cause sparking.

### CHANGING PARAMETERS WHEN A LOAD IS ATTACHED

If your load is easily damaged, the amplitude should be reduced to zero before changing the trigger source, frequency, pulse width, or other pulse parameters. This protects the loads from possible short transient effects.

### START-UP CHECK-LIST FOR LOCAL CONTROL

- 1) The instruction manual has been studied thoroughly.
- 2) The "Local Control" section of the "OP1B Interface Programming Manual" has been studied thoroughly.
- 3) The output module is connected to the mainframe as shown in the "Basic Test Arrangement" section. (The output module should always be connected to the mainframe BEFORE power is applied.)
- 4) The load is connected to the output banana posts. (The output post is red, and ground black). For initial testing, it is recommended that a resistive load be used. Factory tests are conducted using a 0.1 Ohm, 40 Watt resistive load.
- 5) Turn on the prime power to the mainframe. The main menu will appear.
- 6) The arrow pointer should be pointing at the frequency menu item. If it is not, press the MOVE button until it is.
- 7) Press the CHANGE button. The frequency submenu will appear. Rotate the ADJUST knob until the frequency is set at the desired setting. The arrow pointer should be pointing at the "Internal" choice. If it is not, press MOVE until it is.
- 8) Press CHANGE to return to the main menu.
- 9) Press the MOVE button to move the arrow pointer to the pulse width menu item. Press CHANGE to bring up the pulse width submenu, and rotate the ADJUST knob until the pulse width is set at the desired setting. The arrow pointer should be pointing at the "Normal" choice. If it is not, press MOVE until it is. Press CHANGE to return to the main menu.
- 10) Connect a scope probe across the resistive test load. In addition, a current probe may be used to monitor the load current.
- 11) Press the MOVE button to move the arrow pointer is pointing at the output item. Press CHANGE to bring up the output submenu. The arrow pointer should be initially be pointing at the "Output Off" choice. Press MOVE so that the arrow pointer is pointing at the "Output On" choice. (The mainframe is now supplying a trigger to the output module.) Press CHANGE to return to the main menu.
- 12) Press the MOVE button to move the arrow pointer to the amplitude menu item. Press CHANGE to bring up the amplitude submenu, and rotate the ADJUST knob until the amplitude is set at the desired setting. A rectangular pulse should appear

on the scope and the amplitude should increase as the ADJUST knob is rotated.

- 13) Observe the pulse width and pulse period on the scope and confirm that the duty cycle does not exceed 1% and that the peak current does not exceed 200 Amps.
- 14) Adjust pulse width, pulse period (i.e. PRF) and amplitude to obtain the desired settings.
- 15) If additional assistance is required:

Tel: (613) 226-5772, Fax: (613) 226-2802

Email: [info@avtechpulse.com](mailto:info@avtechpulse.com)

## CALIBRATION ADJUSTMENTS

### ADJUSTING AMPLITUDE ACCURACY

If it is found that the output amplitude settings (as set by the front-panel controls or programming commands) do not agree exactly with measured values of amplitude (i.e., by examining the output on an oscilloscope) in one of these ranges, the amplitude calibration can be updated using software commands.

The following procedure is suggested:

- 1) Connect a precision, high-power resistive load to the output. (As an example, suppose  $0.1 \Omega$  is used.)
- 2) Connect the pulse generator to a computer using the GPIB or RS232 ports.
- 3) Turn on the pulse generator, and set the time controls (frequency, delay, pulse width) to typical values.
- 4) Turn on the outputs.
- 5) Set the output amplitude to 80% of the maximum (i.e. 160A).
- 6) Observe the voltage across the load. (Using the  $1\Omega$  example, suppose that 16.2V is observed.) From this, calculate the measured current (162A in this example).
- 7) Send the measured value to the instrument using the following command:

```
diag:ampl:cal 162A
```

The internal software compares the supplied measured value to the programmed value, and adjusts the internal calibration data to null out any differences.

- 8) Observe the voltage across the load again. The amplitude setting should now agree with the measured value.

### OTHER CALIBRATION PROCEDURES

Please visit <http://www.avtechpulse.com/appnote/> for the latest recommended procedures for calibrating amplitude and timing parameters.

## PROGRAMMING YOUR PULSE GENERATOR

### KEY PROGRAMMING COMMANDS

The “OP1B Interface Programming Manual” describes in detail how to connect the pulse generator to your computer, and the programming commands themselves. A large number of commands are available; however, normally you will only need a few of these. Here is a basic sample sequence of commands that might be sent to the instrument after power-up:

```
*rst                (resets the instrument)
trigger:source internal (selects internal triggering)
frequency 10 Hz      (sets the frequency to 10 Hz)
pulse:width 100 us   (sets the pulse width to 100 us)
pulse:delay 10 us    (sets the delay to 10 us)
output on            (turns on the output)
source:current 150 A (sets the current amplitude to 150 amperes)
```

For triggering a single event, this sequence would be more appropriate:

```
*rst                (resets the instrument)
trigger:source hold  (turns off all triggering)
pulse:width 200 us   (sets the pulse width to 200 us)
output on            (turns on the output)
source:current 100 A (sets the current amplitude to 100 amperes)
trigger:source immediate (generates a single non-repetitive trigger event)
trigger:source hold  (turns off all triggering)
output off           (turns off the output)
```

To set the instrument to trigger from an external TTL signal applied to the rear-panel TRIG connector, use:

```
*rst                (resets the instrument)
trigger:source external (selects external triggering)
pulse:width 50 us      (sets the pulse width to 50 us)
pulse:delay 10 us      (sets the delay to 10 us)
source:current 50      (sets the current amplitude to 50 amperes)
output on            (turns on the output)
```



To set the instrument to trigger from an external TTL signal applied to the rear-panel TRIG connector, and have the output pulse width track the pulse width of the input trigger, use:

*rst	(resets the instrument)
trigger:source external	(selects internal triggering)
pulse:width in	(sets the pulse width to $PW_{OUT} = PW_{IN}$ mode)
source:current 105 A	(sets the current amplitude to 105 amperes)
output on	(turns on the output)

Beware the in the  $PW_{OUT} = PW_{IN}$  mode, the onus is on the user to make sure that all duty cycle ratings are observed.

These commands will satisfy 90% of your programming needs.

## ALL PROGRAMMING COMMANDS

For more advanced programmers, a complete list of the available commands is given below. These commands are described in detail in the "OP1B Interface Programming Manual". (Note: this manual also includes some commands that are not implemented in this instrument. They can be ignored.)

<u>Keyword</u>	<u>Parameter</u>	<u>Notes</u>
DIAGnostic:		
:AMPLitude		
:CALibration:	<numeric value>	[no query form]
LOCAL		
OUTPut:		
:[STATe]	<boolean value>	
:PROTection		
:TRIPped?		[query only]
REMOTE		
[SOURce]:		
:FREQuency		
[:CW   FIXed]	<numeric value>	
[SOURce]:		
:CURRent		
[:LEVel]		
[:IMMediate]		
[:AMPLitude]	<numeric value>   EXTernal	
:PROTection		
:TRIPped?		[query only]
[SOURce]:		
:PULSe		
:PERiod	<numeric value>	

:WIDTh	<numeric value>   IN	
:DCYClE	<numeric value>	
:HOLD	WIDTh   DCYClE	
:DELay	<numeric value>	
:GATE		
:TYPE	ASYNc   SYNc	
:LEVel	HIGH   LOW	
STATUS:		
:OPERation		
:[EVENt]?		[query only, always returns "0"]
:CONDition?		[query only, always returns "0"]
:ENABle	<numeric value>	[implemented but not useful]
:QUESTionable		
:[EVENt]?		[query only, always returns "0"]
:CONDition?		[query only, always returns "0"]
:ENABle	<numeric value>	[implemented but not useful]
SYSTEM:		
:COMMunicate		
:GPIB		
:ADDReSS	<numeric value>	
:SERial		
:CONTRol		
:RTS	ON   IBFull   RFR	
:[RECeive]		
:BAUD	1200   2400   4800   9600	
:BITS	7   8	
:ECHO	<boolean value>	
:PARity		
:[TYPE]	EVEN   ODD   NONE	
:SBITS	1   2	
:ERRor		
:[NEXT]?		[query only]
:COUNT?		[query only]
:VERSion?		[query only]
TRIGger:		
:SOURce	INTernal   EXTernal   MANual   HOLD   IMMEDIATE	
*CLS		[no query form]
*ESE	<numeric value>	
*ESR?		[query only]
*IDN?		[query only]
*OPC		
*SAV	0   1   2   3	[no query form]
*RCL	0   1   2   3	[no query form]
*RST		[no query form]
*SRE	<numeric value>	
*STB?		[query only]
*TST?		[query only]
*WAI		[no query form]