



AVTECH ELECTROSYSTEMS LTD.

NANOSECOND WAVEFORM ELECTRONICS
SINCE 1975

P.O. BOX 265
OGDENSBURG, NY
U.S.A. 13669-0265
TEL: (315) 472-5270
FAX: (613) 226-2802

TEL: 1-800-265-6681
FAX: 1-800-561-1970

e-mail: info@avtechpulse.com
<http://www.avtechpulse.com>

P.O. BOX 5120 STN. F
OTTAWA, ONTARIO
CANADA K2C 3H4
TEL: (613) 226-5772
FAX: (613) 226-2802

INSTRUCTIONS

MODEL AV-156A-P-B

0 to 5 AMP, 0 to +15 V, 4 μ s RISE TIME

PULSED CONSTANT CURRENT GENERATOR

WITH IEEE 488.2 AND RS-232 CONTROL

SERIAL NUMBER: _____

WARRANTY

Avtech Electrosystems Ltd. warrants products of its manufacture to be free from defects in material and workmanship under conditions of normal use. If, within one year after delivery to the original owner, and after prepaid return by the original owner, this Avtech product is found to be defective, Avtech shall at its option repair or replace said defective item. This warranty does not apply to units which have been disassembled, modified or subjected to conditions exceeding the applicable specifications or ratings. This warranty is the extent of the obligation assumed by Avtech with respect to this product and no other warranty or guarantee is either expressed or implied.

TECHNICAL SUPPORT

Phone: 613-226-5772 or 1-800-265-6681

Fax: 613-226-2802 or 1-800-561-1970

E-mail: info@avtechpulse.com

World Wide Web: <http://www.avtechpulse.com>

TABLE OF CONTENTS

WARRANTY	2
TECHNICAL SUPPORT	2
TABLE OF CONTENTS	3
INTRODUCTION	5
SPECIFICATIONS	6
INSTALLATION	7
VISUAL CHECK	7
PLUGGING IN THE INSTRUMENT	7
FRONT PANEL CONTROLS	8
REAR PANEL CONTROLS	10
GENERAL INFORMATION	11
BASIC PULSE CONTROL	11
MONITOR CIRCUIT	13
TRIGGER MODES	13
GATING MODES	13
TOP COVER REMOVAL	14
RACK MOUNTING	14
LOAD PROTECTION	15
LENZ'S LAW AND INDUCTIVE VOLTAGE SPIKES	15
OUTPUT ON/OFF	15
ATTACHING AND DETACHING LOADS	15
OPEN AND SHORT CIRCUITS	15
OPERATIONAL CHECK	16
CALIBRATION ADJUSTMENTS - INTERNAL TRIMPOTS	19
NULLING CONSTANT CURRENT OFFSETS	19
NULLING AMPLITUDE-DEPENDENT CURRENT OFFSETS	20
NULLING CONSTANT MONITOR OFFSETS	20
ADJUSTING OUTPUT IMPEDANCE	20
ADJUSTING MONITOR CALIBRATION	20
CALIBRATION ADJUSTMENTS - SOFTWARE PROCEDURES	21
ADJUSTING AMPLITUDE ACCURACY	21
ADJUSTING OFFSET ACCURACY	21
ADJUSTING MONITOR ACCURACY	22
PROGRAMMING YOUR PULSE GENERATOR	24

	4
KEY PROGRAMMING COMMANDS _____	24
ALL PROGRAMMING COMMANDS _____	25
<i>PERFORMANCE CHECK SHEET</i> _____	27

INTRODUCTION

The Model AV-156A-P-B pulsed constant current generator is capable of producing rectangular pulses with amplitudes as high as +5 Amperes, with $< 4 \mu\text{s}$ rise and fall times. A DC offset of up to 500 mA may be added to the output. The internal trigger source can be used to trigger the instrument at frequencies between 1 Hz and 10 kHz. An external TTL trigger pulse, a front-panel pushbutton, and a computer can also be used to trigger the instrument. The maximum duty cycle is 20%.

The Model AV-156A-P-B pulse generator is a current pulser. The current amplitude is largely independent of the load voltage. For proper operation, the load voltage ($V_{\text{LOAD}} = I_{\text{LOAD}} \times R_{\text{LOAD}}$) must lie in the range of 0 to +15V.

The AV-156A-P-B features front panel keyboard and adjust knob control of the output pulse parameters along with a four line by 40 character back-lit LCD display of the output amplitude, pulse width, pulse repetition frequency, and delay. The instrument includes memory to store up to four complete instrument setups. The operator may use the front panel or the computer interface to store a complete "snapshot" of all key instrument settings, and recall this setup at a later time.

SPECIFICATIONS

Model:	AV-156A-P-B
Amplitude:	0 to +5 Amperes, for load voltages of 0 to +15 Volts
DC Offset:	0 to +500 mA
Pulse width:	10 μ s to 10 ms
Rise time:	≤ 4 μ s
Fall time:	≤ 4 μ s
PRF:	internal trigger: 1 Hz to 10 kHz external or pushbutton trigger: ≤ 10 Hz
Max. duty cycle:	20%
Output current regulation:	$\leq 2\%$ for load change from 15V to 0V
Trigger required: (external trigger mode)	Internal PW Mode: +5 Volt, 50 ns or wider (TTL)
Monitor output:	Provides an attenuated coincident replica of the main output current pulse. $V_{MON} = I_{LOAD} \times 1 \Omega$
Sync output:	+ 5 Volts, 200 ns wide, will drive 50 Ohm loads
Connectors:	Out, Gate, Trig, Sync, Monitor: BNC
Power, AC:	120/240 Volts (switchable) 50 - 60 Hz
Dimensions:	3.9" x 17" x 14.8"
Chassis material:	anodized aluminum, with blue plastic trim
Mounting:	Any
Temperature range:	+ 10° to + 40° C

INSTALLATION

VISUAL CHECK

After unpacking the instrument, examine to ensure that it has not been damaged in shipment. Visually inspect all connectors, knobs, liquid crystal displays (LCDs), and the handles. Confirm that a power cord and two instrumentation manuals (this manual and the "OP1B Interface Programming Manual") are with the instrument. If the instrument has been damaged, file a claim immediately with the company that transported the instrument.

PLUGGING IN THE INSTRUMENT

Examine the rear of the instrument. There will be a male power receptacle, a fuse holder and the edge of the power selector card visible. Confirm that the power selector is in the correct orientation - it should be marked either 120 or 240, indicating whether it expects 120V AC or 240V AC. If it is not set for the proper voltage, remove the fuse and then grasp the card with a pair of pliers and remove it. Rotate horizontally through 180 degrees. Reinstall the card and the correct fuse. In the 120V setting, a 2A slow blow fuse is required. In the 240V setting, a 1A slow blow fuse is required.

FRONT PANEL CONTROLS

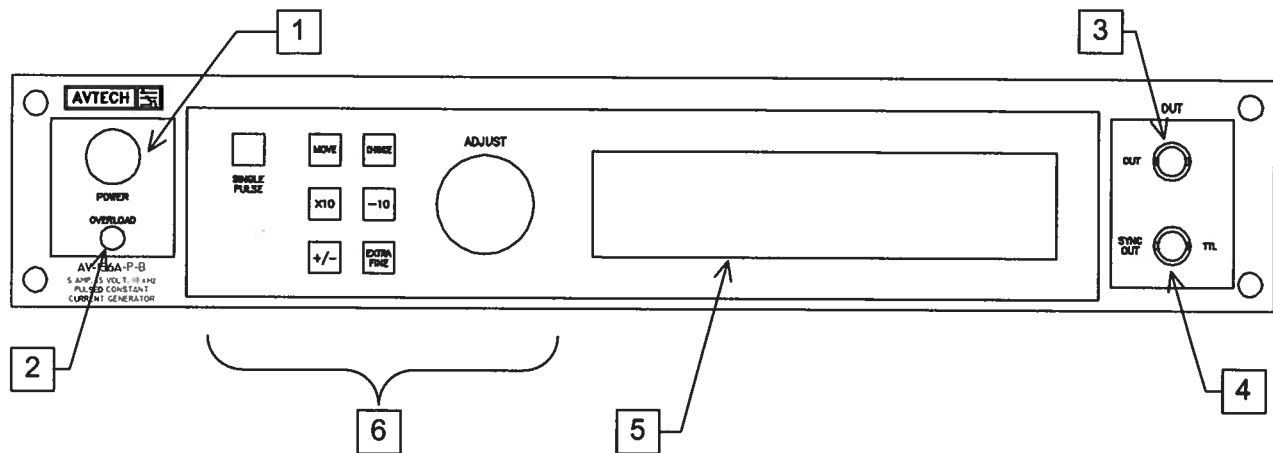

1. **POWER Switch.** The POWER push button switch applies AC prime power to the primaries of the transformer, turning the instrument on. The push button lamp (#382 type) is connected to the +15V DC supply.
2. **OVERLOAD.** The AV-156A-P-B is protected in its internal software against conflicting or dangerous settings. As an additional protective measure, an automatic overload circuit exists, which controls the front panel overload light. If the internal power supply is overloaded due to improper operation, the protective circuit will turn the output of the instrument OFF and turn the indicator light ON. The light will stay ON (i.e. output OFF) for about 5 seconds after which the instrument will attempt to turn ON (i.e. light OFF) for about 1 second. If the overload condition persists, the instrument will turn OFF again (i.e. light ON) for another 5 seconds. If the overload condition has been removed, the instrument will turn on and resume normal operation.

The overload indicator may come on briefly at startup. This is not a cause for concern.

3. **OUT CONNECTOR.** This BNC connector provides the main output signal.
4. **SYNC OUT.** This connector supplies a SYNC output that can be used to trigger other equipment, particularly oscilloscopes. The sync output has an approximate amplitude of +3 Volts to $R_L > 1 \text{ k}\Omega$ with a pulse width of approximately 200 ns.
5. **LIQUID CRYSTAL DISPLAY (LCD).** This LCD is used in conjunction with the keypad to change the instrument settings. Normally, the main menu is displayed, which lists the key adjustable parameters and their current values. The "OP1B Interface Programming Manual" describes the menus and submenus in detail.

6. KEYPAD.

Control Name	Function
MOVE	This moves the arrow pointer on the display.
CHANGE	This is used to enter the submenu, or to select the operating mode, pointed to by the arrow pointer.
×10	If one of the adjustable numeric parameters is displayed, this increases the setting by a factor of ten.
÷10	If one of the adjustable numeric parameters is displayed, this decreases the setting by a factor of ten.
+/-	If one of the adjustable numeric parameters is displayed, and this parameter can be both positive or negative, this changes the sign of the parameter.
EXTRA FINE	This changes the step size of the ADJUST knob. In the extra-fine mode, the step size is twenty times finer than in the normal mode. This button switches between the two step sizes.
ADJUST	This large knob adjusts the value of any displayed numeric adjustable values, such as frequency, pulse width, etc. The adjust step size is set by the "EXTRA FINE" button. When the main menu is displayed, this knob can be used to move the arrow pointer.

REAR PANEL CONTROLS

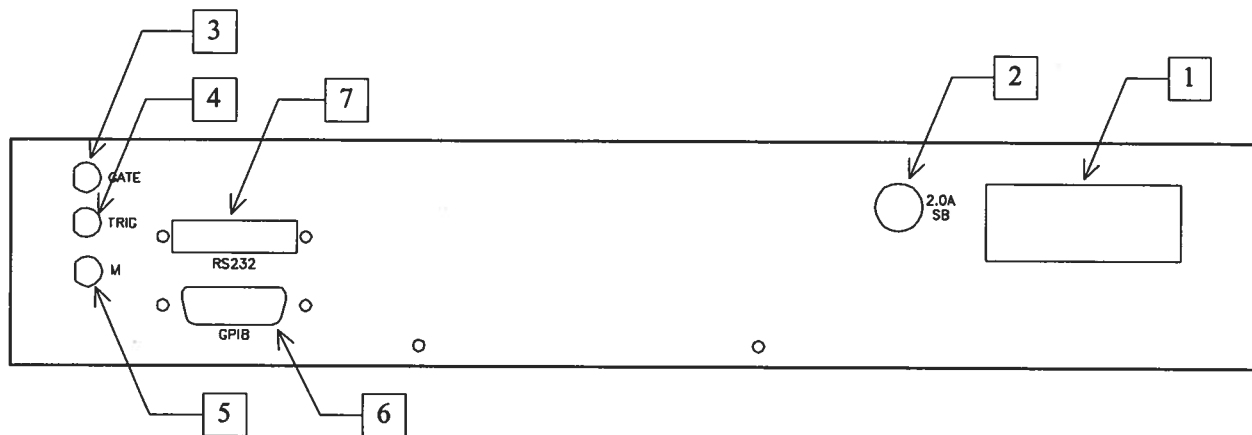

1. **AC POWER INPUT.** A three-pronged recessed male connector is provided on the back panel for AC power connection to the instrument. Also contained in this assembly is a 2.0A slow blow fuse and a removable card that can be removed and repositioned to switch between 120V AC in and 240V AC in.
2. **2.0A SB.** This fuse protects the internal +35V DC power supply.
3. **GATE.** This TTL-level (0 and +5V) logic input can be used to gate the triggering of the instrument. This input can be either active high or active low, depending on the front panel settings or programming commands. (The instrument triggers normally when this input is unconnected).
4. **TRIG.** This TTL-level (0 and +5V) logic input can be used to trigger the instrument, if the instrument is set to triggering externally. The instrument triggers on the rising edge of this input.
5. **M.** This is a current monitor output. This output provides a voltage waveform that is proportional to the current waveform on the main output. The monitor relationship is: $V_{MON} = 1\Omega \times I_{OUT}$, for a load of $> 1 \text{ k}\Omega$. (The monitor output can also drive a 50Ω load, but the output voltage will be reduced by a factor of two. This output is short-circuit protected.)
6. **GPIB Connector.** A standard GPIB cable can be attached to this connector to allow the instrument to be computer-controlled. See the "OP1B Interface Programming Manual" for more details on GPIB control.
7. **RS-232 Connector.** A standard serial cable with a 25-pin male connector can be attached to this connector to allow the instrument to be computer-controlled. See the "OP1B Interface Programming Manual" for more details on RS-232 control.

GENERAL INFORMATION

BASIC PULSE CONTROL

This instrument can be triggered by several sources - its own internal clock, an external TTL trigger signal, the front-panel "SINGLE PULSE" pushbutton, or by a computer-generated command. In any case, three output channels respond to the trigger: OUT, SYNC, and M. OUT is the signal that is applied to the device under test. Its amplitude and pulse width are variable. The SYNC pulse is a fixed-width TTL-level reference pulse used to trigger oscilloscopes or other measurement systems. The SYNC pulse serves as a reference point for the delay setting of the OUT pulse. The M output is a voltage waveform that is proportional to the current waveform on OUT. $V_M = 1\Omega \times I_{OUT1}$ for monitor loads of $> 1\text{ k}\Omega$.

When the delay is set to a positive value the OUT pulse precedes the SYNC pulse. This order is reversed for negative delays.

These pulses are illustrated below for a positive delay:

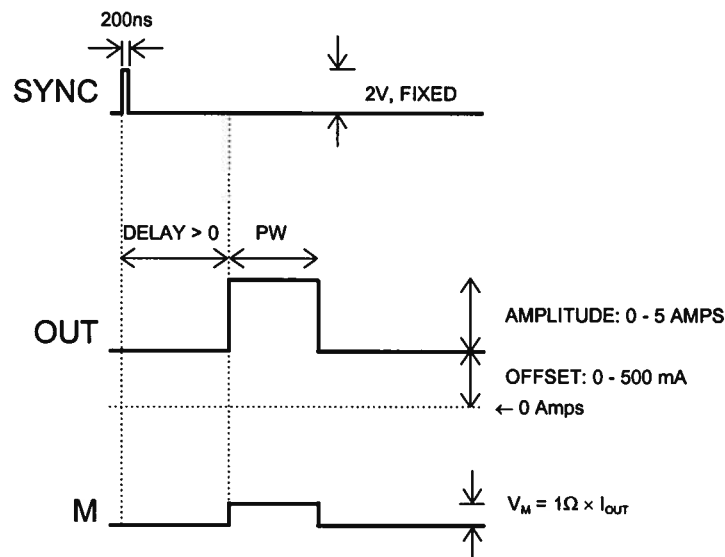

Basic Output Pulses for Delay > 0

The order of the output pulses is reversed for negative delays:

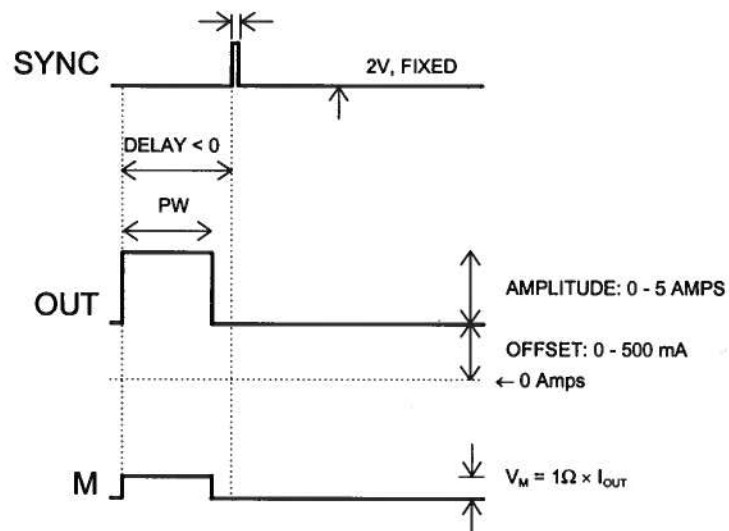

Basic Output Pulses for Delay < 0

The delay, pulse width, and frequency (when in the internal mode), of the OUT pulse can be varied with front panel controls or via the GPIB or RS-232 computer interfaces.

The next figure illustrates the relationship between the signal when an external TTL-level trigger is used:

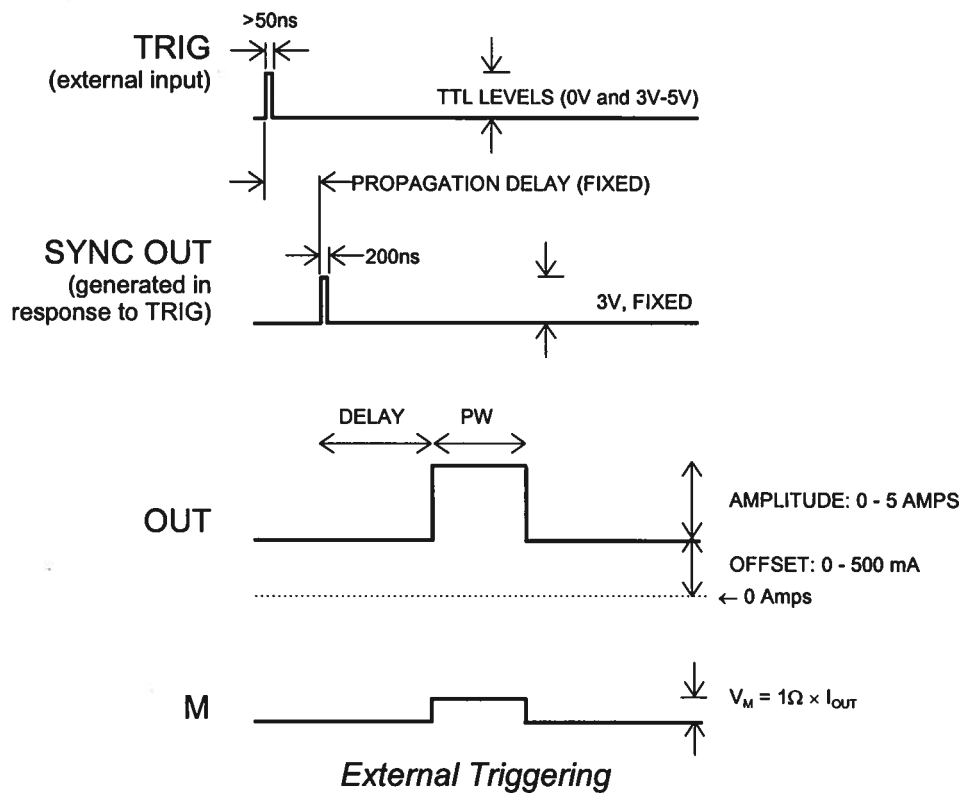

As before, if the delay is negative, the order of the SYNC and OUT pulses is reversed.

MONITOR CIRCUIT

As noted in the previous section, a current monitor output is available. The current monitor output also measures peak amplitude of the most recent pulse, in amperes, and displays it on the front panel LCD. (If a DC offset is present, the peak current will be the sum of the amplitude and the offset.)

TRIGGER MODES

This instrument has four front-panel trigger modes:

- **Internal Trigger:** the instrument controls the trigger frequency, and generates the clock internally.
- **External Trigger:** the instrument is triggered by an external TTL-level clock on the back-panel TRIG connector.
- **Manual Trigger:** the instrument is triggered by the front-panel "SINGLE PULSE" pushbutton.
- **Hold Trigger:** the instrument is set to not trigger at all.

These modes can be selected using the front panel trigger menu, or by using the appropriate programming commands. (See the "OP1B Interface Programming Manual" for more details.)

When being controlled by a computer, there is a fifth trigger mode:

- **Immediate Trigger:** generates a single trigger event. This is the computer-control equivalent of pressing the front-panel "SINGLE PULSE" pushbutton.

GATING MODES

Triggering can be suppressed by a TTL-level signal on the rear-panel GATE connector. The instrument can be set to stop triggering when this input high or low, using the front-panel gate menu or the appropriate programming commands. This input can also be set to act synchronously or asynchronously. When set to asynchronous mode, the GATE will disable the output immediately. Output pulses may be truncated. When set to synchronous mode, the output will complete the full pulse width if the output is high, and then stop triggering. No pulses are truncated in this mode.

AVOID EXCESS POWER DISSIPATION

To prolong the life of the output stages of the instrument, the internal power dissipation should be minimized whenever practical. The power dissipated in the output stage can be calculated using:

$$P_{DISS} = (24 \text{ Volts} - V_{LOAD}) \times I_{PEAK} \times \text{Duty Cycle}$$

To minimize power dissipation, keep the current amplitude and duty cycle as low as practical. Operation into larger load resistance is preferred over operation into a low load resistance, since $V_{LOAD} = I_{PEAK} \times R_{LOAD}$.

TOP COVER REMOVAL

The top cover of the instrument may be removed by removing the four Phillips screws on the top panel. With these four screws removed, the top panel may be slid off by pulling it towards the rear.

The instrument should not be accessed internally unless it has been turned off for ten minutes, to allow all internal capacitors to discharge. The internal capacitor bank stores a considerable amount of energy.

RACK MOUNTING

A rack mounting kit is available. The -R5 rack mount kit may be installed after first removing the one Phillips screw on the side panel adjacent to the front handle.

LOAD PROTECTION

LENZ'S LAW AND INDUCTIVE VOLTAGE SPIKES

This instrument is designed to pulse resistive and diode loads and will exhibit a large output spike when used to drive a load with significant inductance (as predicted by LENZ'S LAW). For this reason the load should be connected to the output using low inductance leads (as short as possible and as heavy a gauge as possible).

The voltage developed across an inductance L (in Henries), when the current is changing at a rate given by di_{LOAD}/dt (in Amps/sec), is: $V_{SPIKE} = L \frac{di_{LOAD}}{dt}$.

OUTPUT ON/OFF

The main outputs may be switched on and off using the front-panel controls or via programming commands. When the output is set "OFF", the main outputs are short-circuited to ground with a relay, and the trigger source is removed from the output stage.

ATTACHING AND DETACHING LOADS

To avoid damaging the loads connected to main outputs, the loads should only be connected to or removed from the instrument when:

- the instrument is off
- the instrument is on, but the outputs are turned off (i.e. the LCD display reads "OUTPUT OFF")

Do not connect loads when the instrument is on and the outputs are turned on. This can cause mild sparking.

CHANGING PARAMETERS WHEN A LOAD IS ATTACHED

If your load is easily damaged, the outputs should be turned off when changing the trigger source, frequency, pulse width, or other pulse parameters. This protects the loads from possible short transient effects.

OPEN AND SHORT CIRCUITS

The AV-156A-P-B will operate properly into a short circuit to ground.

Operation into an open circuit will not damage the instrument in any way, although the monitor circuit may not give the correct reading (which should be zero).

OPERATIONAL CHECK

This section describes a sequence to confirm the basic operation of the instrument. It should be performed after receiving the instrument. It is a useful learning exercise as well.

Before proceeding with this procedure, finish reading this instruction manual thoroughly. Then read the "Local Control" section of the "OP1B Interface Programming Manual" thoroughly. The "Local Control" section describes the front panel controls used in this operational check - in particular, the MOVE, CHANGE, and ADJUST controls.

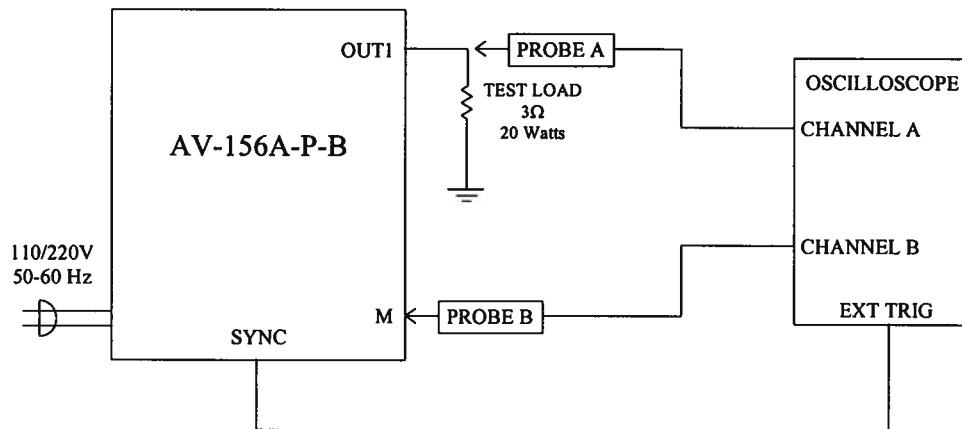

Basic Test Arrangement

- 1) Connect a 20W, 3Ω test load between the OUT connector and ground.
- 2) Connect a cable from the SYNC OUT connector to the TRIG input of an oscilloscope. Set the oscilloscope to trigger externally.
- 3) Connect one oscilloscope probe (channel A) to the OUT load. Connect the other probe to the M output (on the rear panel). On the oscilloscope, set the channel A vertical scale to 5 V/div, the channel B vertical scale to 2 V/div, and the horizontal scale to 50 μs/div.
- 4) Turn on the AV-156A-P-B. The instrument will execute a warm-up sequence during which time the internal capacitor banks are charged. Wait for this sequence to complete. After this delay, the main menu will appear on the LCD.
- 5) To set the AV-156A-P-B to trigger from the internal clock at a PRF of 100 Hz:
 - The arrow pointer should be pointing at the frequency menu item. If it is not, press the MOVE button until it is.

- Press the CHANGE button. The frequency submenu will appear. Rotate the ADJUST knob until the frequency is set at 100 Hz.
 - The arrow pointer should be pointing at the “Internal” choice. If it is not, press MOVE until it is.
 - Press CHANGE to return to the main menu.
- 6) To set the delay to 50 μ s:
- Press the MOVE button until the arrow pointer is pointing at the delay menu item.
 - Press the CHANGE button. The delay submenu will appear. Rotate the ADJUST knob until the delay is set at 50 μ s.
 - Press CHANGE to return to the main menu.
- 7) To set the OUT pulse width to 100 μ s:
- Press the MOVE button until the arrow pointer is pointing at the “PW” menu item.
 - Press the CHANGE button. The pulse width submenu will appear. Rotate the ADJUST knob until the pulse width is set at 100 μ s.
 - The arrow pointer should be pointing at the “Normal” choice. If it is not, press MOVE until it is.
 - Press CHANGE to return to the main menu.
- 8) At this point, nothing should appear on the oscilloscope.
- 9) To enable the output:
- Press the MOVE button until the arrow pointer is pointing at the output menu item.
 - Press the CHANGE button. The output submenu will appear.
 - Press MOVE until the arrow pointer is pointing at the “ON” choice.
 - Press CHANGE to return to the main menu.
- 10) To change the OUT output amplitude:

- Press the MOVE button until the arrow pointer is pointing at the AMP menu item.
- Press the CHANGE button. The amplitude submenu will appear. Rotate the ADJUST knob until the amplitude is set at 5A.
- Observe the oscilloscope. You should see 100 μ s wide, 15V pulses (i.e., $5A \times 3\Omega = 15V$) on the probe connected to the OUT main output. The other probe, connected to the M monitor output, should show 100 μ s, 5V pulses (i.e. $5A \times 1V/A$).
- Press CHANGE to return to the main menu.

11) To change the OUT output offset:

- Press the MOVE button until the arrow pointer is pointing at the OS menu item.
- Press the CHANGE button. The amplitude submenu will appear. Rotate the ADJUST knob until the amplitude is set at 200 mA.
- Observe the oscilloscope. The main output pulse should shift upwards by 600 mV (i.e., $200 \text{ mA} \times 3\Omega = 600 \text{ mV}$).
- Press CHANGE to return to the main menu.

12) Try varying the pulse width, by repeating step (7). As you rotate the ADJUST knob, the pulse width on the oscilloscope will change. It should agree with the displayed value. Stay below 20% duty cycle.

13) This completes the operational check.

If additional assistance is required:

Tel: (613) 226-5772, Fax: (613) 226-2802
Email: info@avtechpulse.com

CALIBRATION ADJUSTMENTS - INTERNAL TRIMPOTS

The output stage has five trimming potentiometers ("trimpots") that can be used to adjust the performance of the output circuit. These trimpots are preset at the factory and should not normally require adjusting after delivery. These controls can be accessed by removing the top panel of the instrument, and by locating the output-stage module. The output module is illustrated in the figure below.

The locations of the trimpots (designated TP1-TP5) are shown below. All should be accessible through the heatsinking.

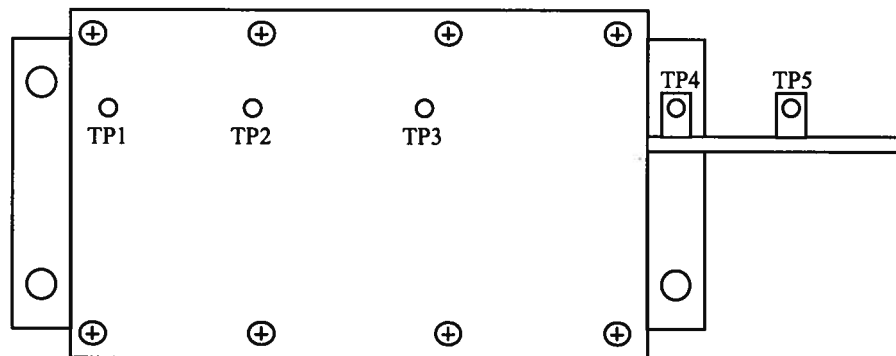

Location of Trimpots

These trimpots can be used to adjust or calibrate the following properties:

- Current offsets on the main outputs.
- Voltage offsets on the monitor outputs.
- Monitor calibration.
- Output impedance.

NULLING CONSTANT CURRENT OFFSETS

If a small constant current offset is observed on one of the main outputs, TP2 can be rotated to reduce it to zero. Note that the output stage is incapable of generating a negative current, due to the presence of a diode in series with the output.

NULLING AMPLITUDE-DEPENDENT CURRENT OFFSETS

If a small amplitude-dependent current offset is observed on one of the main outputs, TP1 can be rotated to null it out. Rotate TP1 while adjusting the output amplitude from the front panel, until the offset does not vary with amplitude.

NULLING CONSTANT MONITOR OFFSETS

If a small constant voltage offset is observed on one of the monitor outputs, TP5 can be rotated to reduce it to zero.

ADJUSTING OUTPUT IMPEDANCE

Ideally, the outputs of the pulsed current sources should be independent of the output voltages, within the 0 to +15V compliance voltage range. This condition represents infinite output impedance. If a load voltage/output current dependence is present, the output impedance needs to be adjusted.

To adjust the output impedance, connect a 20W, 3.0Ω load to the output. Set the output amplitude to 5A and observe the load voltage on an oscilloscope. The load voltage should have an amplitude of approximately 15V (i.e. $5A \times 3\Omega = 15V$). Note the exact value. Now replace the 3.0Ω load with a 1.5Ω load. The load voltage should fall by to approximately 7.5V (i.e. $5A \times 1.5\Omega = 7.5V$). Note the exact value. If the second voltage is not exactly one-half of the first voltage, adjust TP3 and repeat *both* measurements (3.0Ω and 1.5Ω) again. Repeat as required.

ADJUSTING MONITOR CALIBRATION

Just as the current amplitude of the main outputs can exhibit a load-voltage dependence, the voltage amplitude of the current monitors can also exhibit such a dependence if not adjusted properly.

To null out the monitor load voltage dependence, connect a 20W, 3.0Ω load to the output. Set the output amplitude to 5A and observe the monitor voltage on an oscilloscope. The monitor voltage should have an amplitude of approximately 5V (i.e. $5A \times 1 V/A = 5V$). Note the exact value. Now replace the 3.0Ω load with a 1.5Ω load. The monitor voltage not change, since the current amplitude has not changed (i.e. $5A \times 1 V/A = 5V$). Note the exact value. If the second voltage is not exactly equal to the first voltage, adjust TP4 and repeat *both* measurements (3.0Ω and 1.5Ω) again. Repeat as required.

CALIBRATION ADJUSTMENTS - SOFTWARE PROCEDURES

ADJUSTING AMPLITUDE ACCURACY

If it is found that the output amplitude setting (as set by the front-panel controls or programming commands) does not agree exactly with measured values of amplitude (i.e., by examining the output on an oscilloscope), the amplitude calibration can be updated using software commands.

The following procedure is suggested:

- 1) Connect a precision resistive load to the output. (As an example, suppose 2.0Ω is used.)
- 2) Connect the pulse generator to a computer using the GPIB or RS232 ports.
- 3) Turn on the pulse generator, and set the time controls (frequency, delay, pulse width) to typical values.
- 4) Turn on the outputs.
- 5) Set the output amplitude to its maximum value (5.0A).
- 6) Observe the voltage across the load. (Continuing the 2.0Ω example, suppose that 10.25V is observed.) From this, calculate the measured current (5.125A).
- 7) Send one of the following commands to the instrument via the computer interface:
 - `diag:ampl:cal 5.125A`

The internal software compares the supplied measured value to the programmed value, and adjusts the internal calibration data to null out any differences.

- 8) Observe the voltage across the load again. The amplitude setting should now agree with the measured value.

ADJUSTING OFFSET ACCURACY

If it is found that the output offset setting (as set by the front-panel controls or programming commands) does not agree exactly with measured values of DC offset (i.e., by examining the output on an oscilloscope), the amplitude calibration can be updated using software commands.

The following procedure is suggested:

- 1) Connect a precision resistive load to the output. (As an example, suppose 2.0Ω is used.)
- 2) Connect the pulse generator to a computer using the GPIB or RS232 ports.
- 3) Turn on the pulse generator, and set the time controls (frequency, delay, pulse width) to typical values.
- 4) Turn on the outputs.
- 5) Set the output amplitude to zero.
- 6) Set the output offset to 500 mA.
- 7) Observe the voltage across the load. (Continuing the 2.0Ω example, suppose that 1.025V is observed.) From this, calculate the measured current (.5125A).
- 8) Send one of the following commands to the instrument via the computer interface:
 - `diag:offset:cal 0.5125A`

The internal software compares the supplied measured value to the programmed value, and adjusts the internal calibration data to null out any differences.

- 9) Observe the voltage across the load again. The offset setting should now agree with the measured value.

ADJUSTING MONITOR ACCURACY

If it is found that the current monitor readings (as displayed on the front-panel) do not agree exact with measured values of amplitude (i.e., by examining the output on an oscilloscope), the monitor calibration can be updated using software commands.

The following procedure is suggested:

- 1) Connect a precision resistive load to the output. (As an example, suppose 2.0Ω is used.)
- 2) Connect the pulse generator to a computer using the GPIB or RS232 ports.
- 3) Turn on the pulse generator, and set the time controls (frequency, delay, pulse width) to typical values.
- 4) Turn on the outputs.

- 5) Set the output amplitude to its maximum value (5.0A).
- 6) Observe the voltage across the load. (Continuing the 2.0Ω example, suppose that 10.25V is observed.) From this, calculate the measured current (5.125A).
- 7) Send one of the following commands to the instrument via the computer interface:

- `diag:mon:cal 5.125A`

The internal software compares the supplied measured value to the monitor reading, and adjusts the internal calibration data to null out any differences.

- 8) Observe the voltage across the load again. The monitor reading should now agree with the measured value.

Note that this procedure affects the current monitor readings shown on the front-panel display (or read using the "measure:amplitude?" commands) only. It does not change the waveforms present on the rear-panel monitor connectors.

PROGRAMMING YOUR PULSE GENERATOR

KEY PROGRAMMING COMMANDS

The "OP1B Interface Programming Manual" describes in detail how to connect the pulse generator to your computer, and the programming commands themselves. A large number of commands are available; however, normally you will only need a few of these. Here is a basic sample sequence of commands that might be sent to the instrument after power-up, using the internal trigger source:

*rst	(resets the instrument)
trigger:source internal	(selects internal triggering)
frequency 1 Hz	(sets the frequency to 1 Hz)
pulse:width 1 ms	(sets the pulse width to 1 ms)
pulse:delay 10 ms	(sets the delay to 10 ms)
output on	(turns on the output)
source:current 2 A	(sets the current amplitude to 2 amperes)
source:current:low 0.2 A	(sets the DC offset to 0.2 amperes)
measure:amplitude?	(this returns the peak current, in amperes, as measured by the monitor circuit)

For triggering a single event, this sequence would be more appropriate:

*rst	(resets the instrument)
trigger:source hold	(turns off all triggering)
pulse:width 1 ms	(sets the pulse width to 1 ms)
pulse:delay 10 ms	(sets the delay to 10 ms)
output on	(turns on the output)
source:current 2 A	(sets the current amplitude to 2 amperes)
source:current:low 0.2 A	(sets the DC offset to 0.2 amperes)
trigger:source immediate	(generates a single non-repetitive trigger event)
trigger:source hold	(turns off all triggering)
output off	(turns off both outputs)

These commands will satisfy 90% of your programming needs.

ALL PROGRAMMING COMMANDS

For more advanced programmers, a complete list of the available commands is given below. These commands are described in detail in the "OP1B Interface Programming Manual". (Note: this manual also includes some commands that are not implemented in this instrument. They can be ignored.)

<u>Keyword</u>	<u>Parameter</u>	<u>Notes</u>
DIAGnostic:		
:AMPLitude		
:CALibration	<numeric value>	[no query form]
:MONitor		
:CALibration	<numeric value>	[no query form]
:STEP	<numeric value>	
:OFFSet		
:CALibration	<numeric value>	[no query form]
LOCAL		
MEASure:		
:AMPLitude?		[query only]
OUTPut:		
:[STATE]	<boolean value>	
:PROTection		
:TRIPped?		[query only]
REMOTE		
[SOURce]:		
:FREQuency		
:[CW FIXed]	<numeric value>	
[SOURce]:		
:CURRent		
:[LEVel]		
:[IMMediate]		
:[AMPLitude]	<numeric value>	
:LOW	<numeric value>	
:PROTection		
:TRIPped?		[query only]
[SOURce]:		
:PULSe		
:PERiod	<numeric value>	
:WIDTh	<numeric value>	
:DCYClE	<numeric value>	
:HOLD	WIDTh DCYClE	
:DELay	<numeric value>	
:GATE		
:LEVel	High Low	
:TYPE	ASYNc SYNc	
STATUS:		
:OPERation		
:[EVENt]?		[query only, always returns "0"]
:CONDition?		[query only, always returns "0"]
:ENABle	<numeric value>	[implemented but not useful]
:QUEStionable		
:[EVENt]?		[query only, always returns "0"]
:CONDition?		[query only, always returns "0"]
:ENABle	<numeric value>	[implemented but not useful]

PERFORMANCE CHECK SHEET

Sept 21 198

emailed to Remstar Sept 21/98

Edition A