



# AVTECH ELECTROSYSTEMS LTD.

NANOSECOND WAVEFORM ELECTRONICS  
SINCE 1975

P.O. BOX 265  
OGDENSBURG, NY  
U.S.A. 13669-0265  
TEL: (315) 472-5270  
FAX: (613) 226-2802

TEL: 1-800-265-6681  
FAX: 1-800-561-1970

e-mail: [info@avtechpulse.com](mailto:info@avtechpulse.com)  
<http://www.avtechpulse.com>

P.O. BOX 5120 STN. F  
OTTAWA, ONTARIO  
CANADA K2C 3H4  
TEL: (613) 226-5772  
FAX: (613) 226-2802

## INSTRUCTIONS

MODEL AV-156B-B-P-CMPD

0 to 1 AMP, 0 to +5 V, 4  $\mu$ s RISE TIME

PULSED CONSTANT CURRENT GENERATOR

WITH IEEE 488.2 AND RS-232 CONTROL

SERIAL NUMBER: \_\_\_\_\_

### WARRANTY

Avtech Electrosystems Ltd. warrants products of its manufacture to be free from defects in material and workmanship under conditions of normal use. If, within one year after delivery to the original owner, and after prepaid return by the original owner, this Avtech product is found to be defective, Avtech shall at its option repair or replace said defective item. This warranty does not apply to units which have been disassembled, modified or subjected to conditions exceeding the applicable specifications or ratings. This warranty is the extent of the obligation assumed by Avtech with respect to this product and no other warranty or guarantee is either expressed or implied.

### TECHNICAL SUPPORT

Phone: 613-226-5772 or 1-800-265-6681

Fax: 613-226-2802 or 1-800-561-1970

E-mail: [info@avtechpulse.com](mailto:info@avtechpulse.com)

World Wide Web: <http://www.avtechpulse.com>

## TABLE OF CONTENTS

<b><i>WARRANTY</i></b>	<b>2</b>
<b><i>TECHNICAL SUPPORT</i></b>	<b>2</b>
<b><i>TABLE OF CONTENTS</i></b>	<b>3</b>
<b><i>INTRODUCTION</i></b>	<b>5</b>
<b><i>SPECIFICATIONS</i></b>	<b>6</b>
<b><i>INSTALLATION</i></b>	<b>7</b>
<b>VISUAL CHECK</b>	<b>7</b>
<b>PLUGGING IN THE INSTRUMENT</b>	<b>7</b>
<b><i>FRONT PANEL CONTROLS</i></b>	<b>8</b>
<b><i>REAR PANEL CONTROLS</i></b>	<b>10</b>
<b><i>GENERAL INFORMATION</i></b>	<b>11</b>
<b>BASIC PULSE CONTROL</b>	<b>11</b>
<b>DUTY CYCLE LIMITATIONS</b>	<b>13</b>
<b>MONITOR CIRCUIT</b>	<b>13</b>
<b>TRIGGER MODES</b>	<b>13</b>
<b>GATING MODES</b>	<b>14</b>
<b>TOP COVER REMOVAL</b>	<b>14</b>
<b>RACK MOUNTING</b>	<b>14</b>
<b><i>LOAD PROTECTION</i></b>	<b>15</b>
<b>DRIVING DIODE LOADS</b>	<b>15</b>
<b>LENZ'S LAW AND INDUCTIVE VOLTAGE SPIKES</b>	<b>15</b>
<b>OUTPUT ON/OFF</b>	<b>15</b>
<b>ATTACHING AND DETACHING LOADS</b>	<b>15</b>
<b>OPEN AND SHORT CIRCUITS</b>	<b>16</b>
<b><i>OPERATIONAL CHECK</i></b>	<b>17</b>
<b><i>AMPLITUDE CALIBRATION PROCEDURES</i></b>	<b>20</b>
<b>STEP 1 - LOW-CURRENT OUTPUT IMPEDANCE ADJUSTMENT</b>	<b>20</b>
<b>STEP 2 - HIGH-CURRENT OUTPUT IMPEDANCE ADJUSTMENT</b>	<b>21</b>
<b>STEP 3 - NULL AMPLITUDE-INDEPENDENT OFFSET</b>	<b>21</b>
<b>STEP 4 - NULL AMPLITUDE-DEPENDENT OFFSET</b>	<b>21</b>
<b>STEP 5 - ADJUST AMPLITUDE CALIBRATION</b>	<b>21</b>
<b>STEP 6 - ADJUST OFFSET CALIBRATION</b>	<b>22</b>
<b>STEP 7 - ADJUST MONITOR OUTPUT CALIBRATION</b>	<b>22</b>
<b>STEP 8 - ADJUST LOW-CURRENT LCD MONITOR CALIBRATION</b>	<b>23</b>

	4
<b>STEP 9 - ADJUST HIGH-CURRENT LCD MONITOR CALIBRATION</b>	<b>23</b>
<b>OTHER CALIBRATION PROCEDURES</b>	<b>23</b>
<b><i>PROGRAMMING YOUR PULSE GENERATOR</i></b>	<b>24</b>
<b>KEY PROGRAMMING COMMANDS</b>	<b>24</b>
<b>ALL PROGRAMMING COMMANDS</b>	<b>25</b>
<b><i>REGULAR MAINTENANCE</i></b>	<b>27</b>
<b><i>PERFORMANCE CHECK SHEET</i></b>	<b>28</b>

Manual Reference: Q:\office\instructword\Av-156\AV-156B-B-P-CMPD.doc, created December 13, 2000

## INTRODUCTION

The Model AV-156B-B-P-CMPD pulsed constant current generator is capable of producing rectangular pulses with amplitudes as high as +1 Amperes, with  $< 4 \mu\text{s}$  rise and fall times. A DC offset of up to 200 mA may be added to the output. The internal trigger source can be used to trigger the instrument at frequencies between 0.1 Hz and 10 kHz. An external TTL trigger pulse, a front-panel pushbutton, and a computer can also be used to trigger the instrument.

In normal operation, the duty cycle may range from 0 to 90%. In the "Invert" mode, the output duty cycle may range from 10% to 100%. A "DC" mode is also provided.

The Model AV-156B-B-P-CMPD pulse generator is a current pulser. The current amplitude is largely independent of the load voltage. For proper operation, the load voltage ( $V_{\text{LOAD}} = I_{\text{LOAD}} \times R_{\text{LOAD}}$ ) must lie in the range of 0 to +5V.

The AV-156B-B-P-CMPD features front panel keyboard and adjust knob control of the output pulse parameters along with a four line by 40 character back-lit LCD display of the output amplitude, pulse width, pulse repetition frequency, and delay. The instrument includes memory to store up to four complete instrument setups. The operator may use the front panel or the computer interface to store a complete "snapshot" of all key instrument settings, and recall this setup at a later time.

Application notes and LabView drivers can be obtained on the Avtech web site, at <http://www.avtechpulse.com/appnote>.

### SPECIFICATIONS

Model:	AV-156B-B-P-CMPD
Amplitude:	0 to +1 Amperes, for load voltages of 0 to +5 Volts
DC Offset:	0 to +200 mA
Pulse width:	10 $\mu$ s to 1 sec
Rise time:	$\leq 4$ us
Fall time:	$\leq 4$ us
PRF:	internal trigger: 0.1 Hz to 10 kHz external or pushbutton trigger: $\leq 10$ Hz
Max. duty cycle:	20%
Output current regulation:	$\leq 2\%$ for load change from 15V to 0V
Trigger required: (external trigger mode)	Internal PW Mode: +5 Volt, 50 ns or wider (TTL)
Monitor output:	Provides an attenuated coincident replica of the main output current pulse. $V_{MON} = I_{LOAD} \times 1 \Omega$
Sync output:	+ 3 Volts, 200 ns wide, will drive 50 Ohm loads
Connectors:	Out, Gate, Trig, Sync, Monitor: BNC
Power, AC:	120/240 Volts (switchable) 50 - 60 Hz
Dimensions:	3.9" x 17" x 14.8"
Chassis material:	anodized aluminum, with blue plastic trim
Mounting:	Any
Temperature range:	+ 10° to + 40° C

## INSTALLATION

### VISUAL CHECK

After unpacking the instrument, examine to ensure that it has not been damaged in shipment. Visually inspect all connectors, knobs, liquid crystal displays (LCDs), and the handles. Confirm that a power cord and two instrumentation manuals (this manual and the "OP1B Interface Programming Manual") are with the instrument. If the instrument has been damaged, file a claim immediately with the company that transported the instrument.

### PLUGGING IN THE INSTRUMENT

Examine the rear of the instrument. There will be a male power receptacle, a fuse holder and the edge of the power selector card visible.

For AC line voltages of 110-120V, the power selector card should be installed so that the "120" marking is visible from the rear of the instrument.

For AC line voltages of 220-240V, the power selector card should be installed so that the "240" marking is visible from the rear of the instrument.

If it is not set for the proper voltage, remove the fuse and then grasp the card with a pair of pliers and remove it. Rotate horizontally through 180 degrees. Reinstall the card and the correct fuse.

In the 120V setting, a 1A slow blow fuse is required. In the 240V setting, a 0.5A slow-blow fuse is required.

## FRONT PANEL CONTROLS

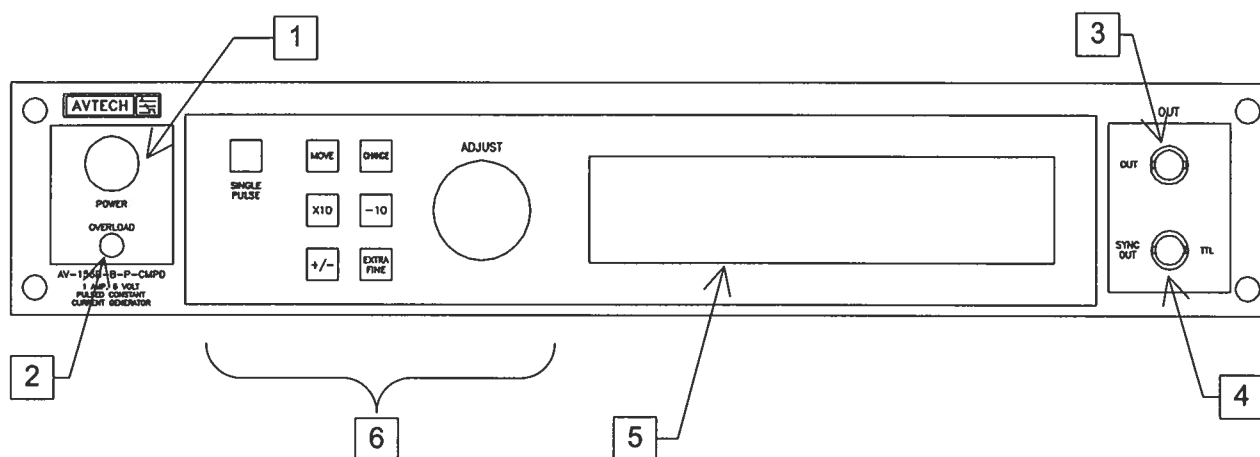

1. **POWER Switch**. The POWER push button switch applies AC prime power to the primaries of the transformer, turning the instrument on. The push button lamp (#382 type) is connected to the +15V DC supply.
2. **OVERLOAD**. The AV-156B-B-P-CMPD is protected in its internal software against conflicting or dangerous settings. As an additional protective measure, an automatic overload circuit exists, which controls the front panel overload light. If the internal power supply is overloaded due to improper operation, the protective circuit will turn the output of the instrument OFF and turn the indicator light ON. The light will stay ON (i.e. output OFF) for about 5 seconds after which the instrument will attempt to turn ON (i.e. light OFF) for about 1 second. If the overload condition persists, the instrument will turn OFF again (i.e. light ON) for another 5 seconds. If the overload condition has been removed, the instrument will turn on and resume normal operation.

The overload indicator may come on briefly at startup. This is not a cause for concern.

3. **OUT CONNECTOR**. This BNC connector provides the main output signal.
4. **SYNC OUT**. This connector supplies a SYNC output that can be used to trigger other equipment, particularly oscilloscopes. The sync output has an approximate amplitude of +3 Volts to  $R_L > 1 \text{ k}\Omega$  with a pulse width of approximately 200 ns.
5. **LIQUID CRYSTAL DISPLAY (LCD)**. This LCD is used in conjunction with the keypad to change the instrument settings. Normally, the main menu is displayed, which lists the key adjustable parameters and their current values. The "OP1B Interface Programming Manual" describes the menus and submenus in detail.



6. KEYPAD.

Control Name	Function
MOVE	This moves the arrow pointer on the display.
CHANGE	This is used to enter the submenu, or to select the operating mode, pointed to by the arrow pointer.
×10	If one of the adjustable numeric parameters is displayed, this increases the setting by a factor of ten.
÷10	If one of the adjustable numeric parameters is displayed, this decreases the setting by a factor of ten.
+/-	If one of the adjustable numeric parameters is displayed, and this parameter can be both positive or negative, this changes the sign of the parameter.
EXTRA FINE	This changes the step size of the ADJUST knob. In the extra-fine mode, the step size is twenty times finer than in the normal mode. This button switches between the two step sizes.
ADJUST	This large knob adjusts the value of any displayed numeric adjustable values, such as frequency, pulse width, etc. The adjust step size is set by the "EXTRA FINE" button.  When the main menu is displayed, this knob can be used to move the arrow pointer.

## REAR PANEL CONTROLS

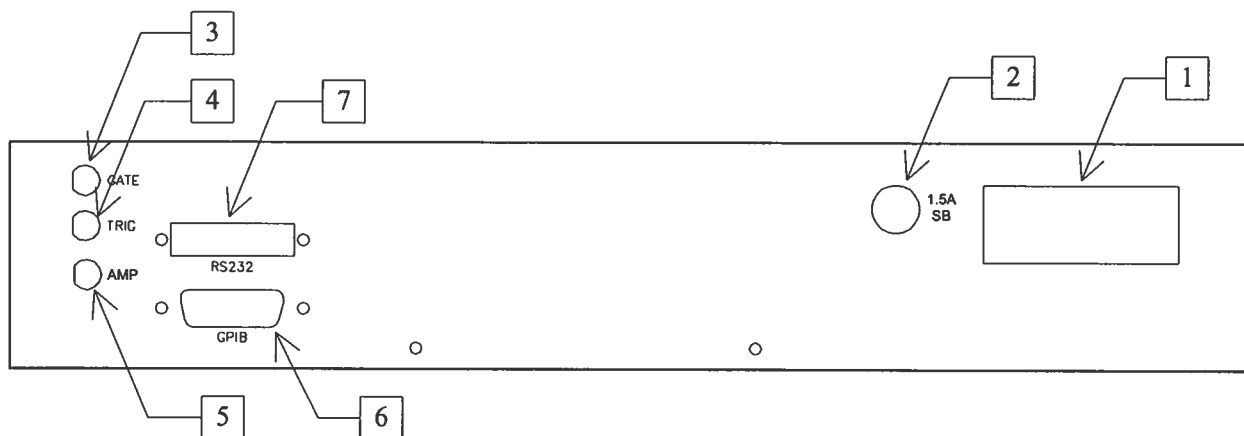

1. **AC POWER INPUT.** A three-pronged recessed male connector is provided on the back panel for AC power connection to the instrument. Also contained in this assembly is a 1A slow blow fuse and a removable card that can be removed and repositioned to switch between 120V AC in and 240V AC in.
2. **1.5A SB.** This fuse protects the internal +24V DC power supply.
3. **GATE.** This TTL-level (0 and +5V) logic input can be used to gate the triggering of the instrument. This input can be either active high or active low, depending on the front panel settings or programming commands. (The instrument triggers normally when this input is unconnected).
4. **TRIG.** This TTL-level (0 and +5V) logic input can be used to trigger the instrument, if the instrument is set to triggering externally. The instrument triggers on the rising edge of this input.
5. **AMP Monitor.** This is a current monitor output. This output provides a voltage waveform that is proportional to the current waveform on the main output. The monitor relationship is:  $V_{MON} = 1\Omega \times I_{OUT}$ , for a load of  $> 1\text{ k}\Omega$ . (The monitor output can also drive a  $50\Omega$  load, but the output voltage will be reduced by a factor of two. This output is short-circuit protected.)
6. **GPIB Connector.** A standard GPIB cable can be attached to this connector to allow the instrument to be computer-controlled. See the "OP1B Interface Programming Manual" for more details on GPIB control.
7. **RS-232 Connector.** A standard serial cable with a 25-pin male connector can be attached to this connector to allow the instrument to be computer-controlled. See the "OP1B Interface Programming Manual" for more details on RS-232 control.

## GENERAL INFORMATION

### BASIC PULSE CONTROL

This instrument can be triggered by several sources - its own internal clock, an external TTL trigger signal, the front-panel "SINGLE PULSE" pushbutton, or by a computer-generated command. In any case, three output channels respond to the trigger: OUT, SYNC, and M. OUT is the signal that is applied to the device under test. Its amplitude and pulse width are variable. The SYNC pulse is a fixed-width TTL-level reference pulse used to trigger oscilloscopes or other measurement systems. The SYNC pulse serves as a reference point for the delay setting of the OUT pulse. The M output is a voltage waveform that is proportional to the current waveform on OUT.  $V_M = 1\Omega \times I_{OUT1}$  for monitor loads of  $> 1\text{ k}\Omega$ .

When the delay is set to a positive value the SYNC pulse precedes the OUT pulse. This order is reversed for negative delays.

These pulses are illustrated below for a positive delay:

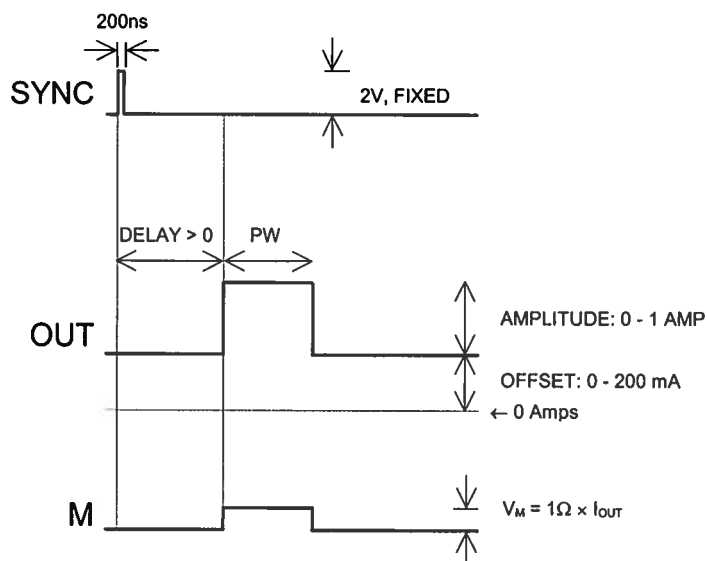

*Basic Output Pulses for Delay > 0*

The order of the output pulses is reversed for negative delays:

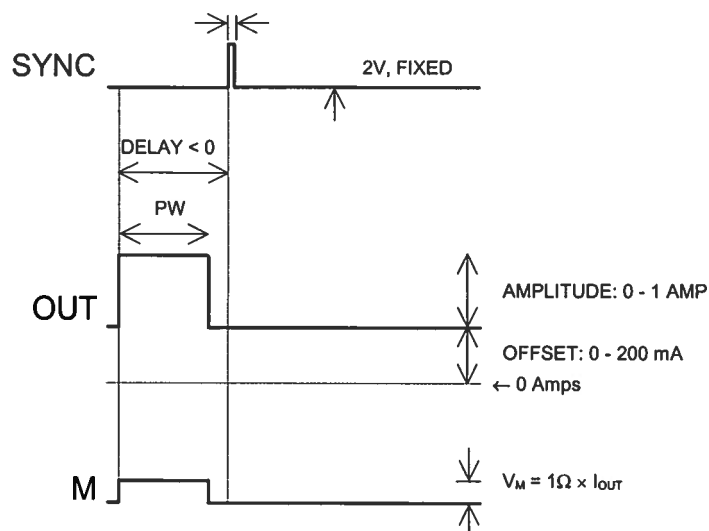

*Basic Output Pulses for Delay  $< 0$*

The delay, pulse width, and frequency (when in the internal mode), of the OUT pulse can be varied with front panel controls or via the GPIB or RS-232 computer interfaces.

The next figure illustrates the relationship between the signal when an external TTL-level trigger is used:

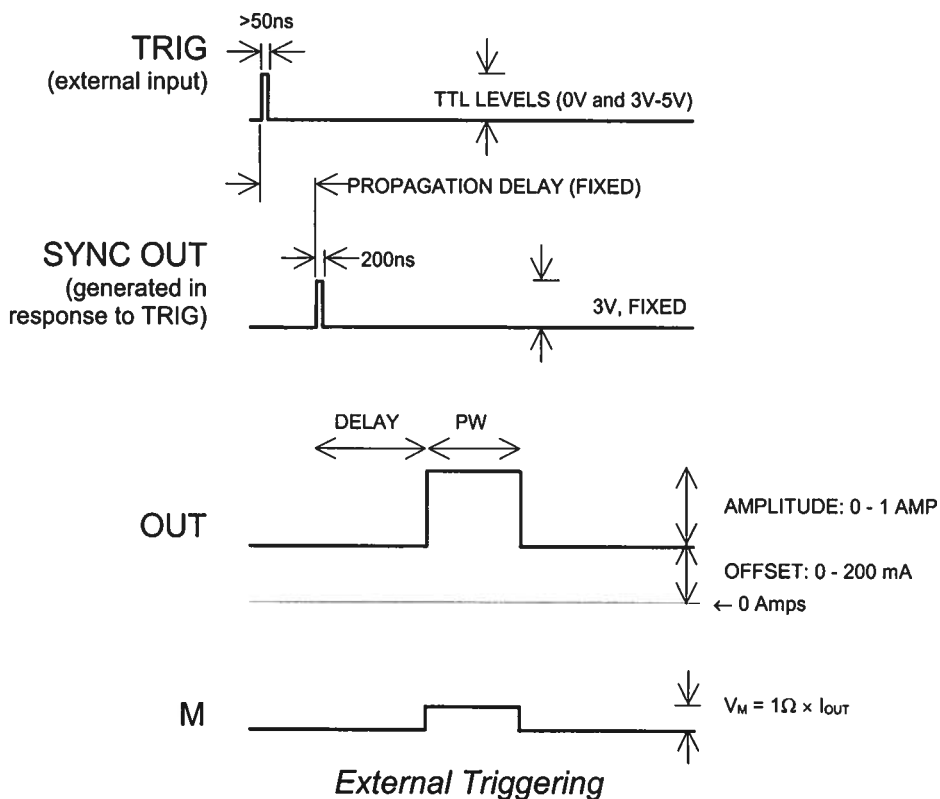

As before, if the delay is negative, the order of the SYNC and OUT pulses is reversed.

### DUTY CYCLE LIMITATIONS

In the normal pulse width control mode, the duty cycle may be adjusted from near 0% to 90%. Operation above 90% may result in unstable pulse widths.

To achieve reliable operation in the 90% to 100% range, use the “Invert” feature. For example, by setting the programmed pulse width or duty cycle to give a nominal 3% duty cycle, and then using the front-panel “Invert” menu to invert the output, you will obtain an actual duty cycle of  $100\% - 3\% = 97\%$ . The invert feature can also be controlled by the “source:pulse:polarity” command. See the programming manual for details.

A DC mode is provided for true 100% duty cycle operation. This is enabled by selecting the “DC Output” mode in the pulse width menu, or by using the “source:function:shape DC” command.

### MONITOR CIRCUIT

As noted in the previous section, a current monitor output is available. The current monitor output also measures peak amplitude of the most recent pulse, in amperes, and displays it on the front panel LCD. (If a DC offset is present, the peak current will be the sum of the amplitude and the offset.)

### TRIGGER MODES

This instrument has four front-panel trigger modes:

- Internal Trigger: the instrument controls the trigger frequency, and generates the clock internally.
- External Trigger: the instrument is triggered by an external TTL-level clock on the back-panel TRIG connector.
- Manual Trigger: the instrument is triggered by the front-panel “SINGLE PULSE” pushbutton.
- Hold Trigger: the instrument is set to not trigger at all.

These modes can be selected using the front panel trigger menu, or by using the appropriate programming commands. (See the “OP1B Interface Programming Manual” for more details.)

When being controlled by a computer, there is a fifth trigger mode:

- Immediate Trigger: generates a single trigger event. This is the computer-control equivalent of pressing the front-panel “SINGLE PULSE” pushbutton.

## GATING MODES

Triggering can be suppressed by a TTL-level signal on the rear-panel GATE connector. The instrument can be set to stop triggering when this input high or low, using the front-panel gate menu or the appropriate programming commands. This input can also be set to act synchronously or asynchronously. When set to asynchronous mode, the GATE will disable the output immediately. Output pulses may be truncated. When set to synchronous mode, the output will complete the full pulse width if the output is high, and then stop triggering. No pulses are truncated in this mode.

## AVOID EXCESS POWER DISSIPATION

To prolong the life of the output stages of the instrument, the internal power dissipation should be minimized whenever practical. The power dissipated in the output stage can be calculated using:

$$P_{DISS} = (12 \text{ Volts} - V_{LOAD}) \times I_{PEAK} \times DutyCycle$$

To minimize power dissipation, keep the current amplitude and duty cycle as low as practical. Operation into larger load resistance is preferred over operation into a low load resistance, since  $V_{LOAD} = I_{PEAK} \times R_{LOAD}$ .

## TOP COVER REMOVAL

The top cover of the instrument may be removed by removing the four Phillips screws on the top panel. With these four screws removed, the top panel may be slid off by pulling it towards the rear.

The instrument should not be accessed internally unless it has been turned off for ten minutes, to allow all internal capacitors to discharge. The internal capacitor bank stores a considerable amount of energy.

## RACK MOUNTING

A rack mounting kit is available. The -R5 rack mount kit may be installed after first removing the one Phillips screw on the side panel adjacent to the front handle.

## LOAD PROTECTION

### DRIVING DIODE LOADS

When driving laser diode loads (or any other diode load), the anode should be connected to the output of the AV-156B-B-P-CMPD, and the cathode should be connected to ground. This is illustrated below:

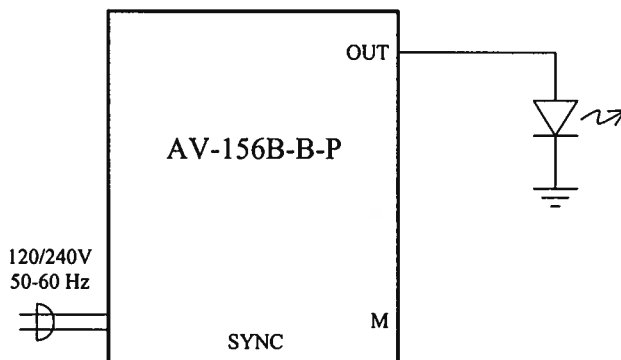

Reversing this connection may cause the diode to breakdown, possibly damaging it.

### LENZ'S LAW AND INDUCTIVE VOLTAGE SPIKES

This instrument is designed to pulse resistive and diode loads and will exhibit a large output spike when used to drive a load with significant inductance (as predicted by LENZ'S LAW). For this reason the load should be connected to the output using low inductance leads (as short as possible and as heavy a gauge as possible).

The voltage developed across an inductance  $L$  (in Henries), when the current is changing at a rate given by  $di_{LOAD}/dt$  (in Amps/sec), is:  $V_{SPIKE} = L \frac{di_{LOAD}}{dt}$ .

### OUTPUT ON/OFF

The main outputs may be switched on and off using the front-panel controls or via programming commands. When the output is set "OFF", the main outputs are short-circuited to ground with a relay, and the trigger source is removed from the output stage.

### ATTACHING AND DETACHING LOADS

To avoid damaging the loads connected to main outputs, the loads should only be connected to or removed from the instrument when:

- the instrument is off

- the instrument is on, but the outputs are turned off (i.e. the LCD display reads "OUTPUT OFF")

Do not connect loads when the instrument is on and the outputs are turned on. This can cause mild sparking.

### CHANGING PARAMETERS WHEN A LOAD IS ATTACHED

If your load is easily damaged, the outputs should be turned off when changing the trigger source, frequency, pulse width, or other pulse parameters. This protects the loads from possible short transient effects.

### OPEN AND SHORT CIRCUITS

The AV-156B-B-P-CMPD will operate properly into a short circuit to ground.

Operation into an open circuit will not damage the instrument in any way, although the monitor circuit may not give the correct reading (which should be zero).



## OPERATIONAL CHECK

This section describes a sequence to confirm the basic operation of the instrument. It should be performed after receiving the instrument. It is a useful learning exercise as well.

Before proceeding with this procedure, finish reading this instruction manual thoroughly. Then read the “Local Control” section of the “OP1B Interface Programming Manual” thoroughly. The “Local Control” section describes the front panel controls used in this operational check - in particular, the MOVE, CHANGE, and ADJUST controls.

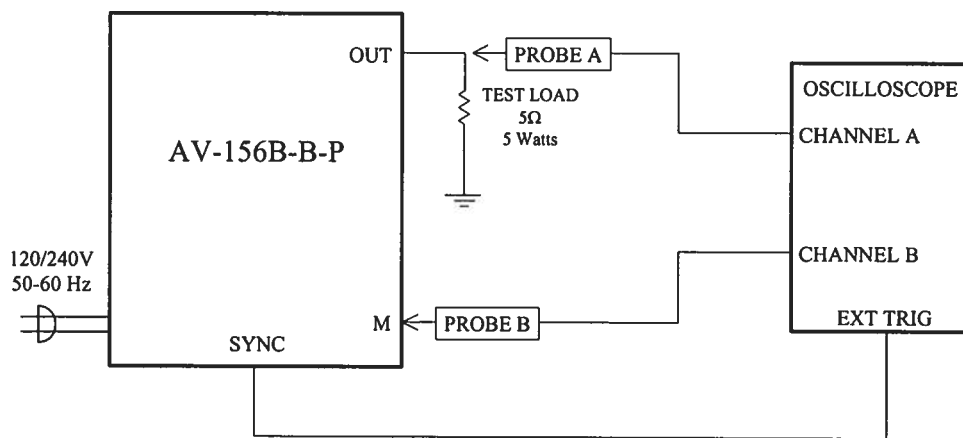

*Basic Test Arrangement*

- 1) Connect a 5W, 5Ω test load between the OUT connector and ground.
- 2) Connect a cable from the SYNC OUT connector to the TRIG input of an oscilloscope. Set the oscilloscope to trigger externally.
- 3) Connect one oscilloscope probe (channel A) to the OUT load. Connect the other probe to the M output (on the rear panel). On the oscilloscope, set the channel A vertical scale to 1 V/div, the channel B vertical scale to 1 V/div, and the horizontal scale to 50 μs/div.
- 4) Turn on the AV-156B-B-P-CMPD. The instrument will execute a warm-up sequence during which time the internal capacitor banks are charged. Wait for this sequence to complete. After this delay, the main menu will appear on the LCD.
- 5) To set the AV-156B-B-P-CMPD to trigger from the internal clock at a PRF of 100 Hz:
  - The arrow pointer should be pointing at the frequency menu item. If it is not, press the MOVE button until it is.

- Press the CHANGE button. The frequency submenu will appear. Rotate the ADJUST knob until the frequency is set at 100 Hz.
  - The arrow pointer should be pointing at the “Internal” choice. If it is not, press MOVE until it is.
  - Press CHANGE to return to the main menu.
- 6) To set the delay to 50  $\mu$ s:
- Press the MOVE button until the arrow pointer is pointing at the delay menu item.
  - Press the CHANGE button. The delay submenu will appear. Rotate the ADJUST knob until the delay is set at 50  $\mu$ s.
  - Press CHANGE to return to the main menu.
- 7) To set the OUT pulse width to 100  $\mu$ s:
- Press the MOVE button until the arrow pointer is pointing at the “PW” menu item.
  - Press the CHANGE button. The pulse width submenu will appear. Rotate the ADJUST knob until the pulse width is set at 100  $\mu$ s.
  - The arrow pointer should be pointing at the “Normal” choice. If it is not, press MOVE until it is.
  - Press CHANGE to return to the main menu.
- 8) At this point, nothing should appear on the oscilloscope.
- 9) To enable the output:
- Press the MOVE button until the arrow pointer is pointing at the output menu item.
  - Press the CHANGE button. The output submenu will appear.
  - Press MOVE until the arrow pointer is pointing at the “ON” choice.
  - Press CHANGE to return to the main menu.
- 10) To change the OUT output amplitude:

- Press the MOVE button until the arrow pointer is pointing at the AMP menu item.
- Press the CHANGE button. The amplitude submenu will appear. Rotate the ADJUST knob until the amplitude is set at 1A.
- Observe the oscilloscope. You should see 100  $\mu$ s wide, 5V pulses (i.e.,  $1A \times 5\Omega = 5V$ ) on the probe connected to the OUT main output. The other probe, connected to the M monitor output, should show 100  $\mu$ s, 1V pulses (i.e.  $1A \times 1V/A$ ).
- Reduce the amplitude to 600 mA.
- Press CHANGE to return to the main menu.

11) To change the OUT output offset:

- Press the MOVE button until the arrow pointer is pointing at the OS menu item.
- Press the CHANGE button. The amplitude submenu will appear. Rotate the ADJUST knob until the amplitude is set at 200 mA.
- Observe the oscilloscope. The main output pulse should shift upwards by 1 V (i.e.,  $200 \text{ mA} \times 5\Omega = 1 \text{ V}$ ).
- Press CHANGE to return to the main menu.

12) Try varying the pulse width, by repeating step (7). As you rotate the ADJUST knob, the pulse width on the oscilloscope will change. It should agree with the displayed value.

13) This completes the operational check.

If additional assistance is required:

Tel: (613) 226-5772, Fax: (613) 226-2802  
Email: [info@avtechpulse.com](mailto:info@avtechpulse.com)

## AMPLITUDE CALIBRATION PROCEDURES

The output stage has five trimming potentiometers ("trimpots") that can be used to adjust the performance of the output circuit. These trimpots are preset at the factory and should not normally require adjusting after delivery. These controls can be accessed by removing the top panel of the instrument, and by locating the output-stage module. The output module is illustrated in the figure below. The locations of the trimpots (designated A-E) are shown below.

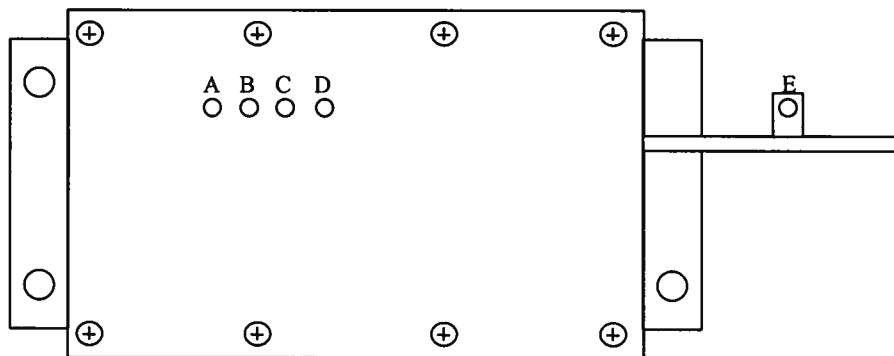

*Location of Trimpots*

The trimpots serve the following functions:

- A: nulls amplitude-dependent offset
- B: nulls amplitude-independent offset
- C: adjusts high-current range output impedance
- D: adjusts low-current range output impedance
- E: adjusts monitor circuit gain

These trimpots are used in conjunction with software commands to calibrate the instrument.

(If your instrument appears to have a different set of trimpots, do not proceed with the following calibration procedure. Older instruments have trimpots labeled "TP1" to "TP5". Consult the instruction manuals that shipped with these instruments for the appropriate calibration procedure.)

### STEP 1 - LOW-CURRENT OUTPUT IMPEDANCE ADJUSTMENT

Ideally, the outputs of the pulsed current sources should be independent of the output voltages, within the 0 to +5V compliance voltage range. This condition represents infinite output impedance. If a load voltage/output current dependence is present, the output impedance needs to be adjusted.

The output stage has two current ranges, of approximately 0 to 0.11A and 0.11A to 1.1A. For this reason, two output impedance adjustments are required.

To adjust the output impedance in the low-current range, connect a 5W,  $5.0\Omega$  load to the output. Set the output amplitude to 0.1 A and observe the load voltage on an oscilloscope. The load voltage should have an amplitude of approximately 0.5V (i.e.  $0.1\text{A} \times 5\Omega = 0.5\text{V}$ ). Note the exact value. Now replace the  $5.0\Omega$  load with a  $2.5\Omega$  load. The load voltage should fall by to approximately 0.25V (i.e.  $0.1\text{A} \times 2.5\Omega = 0.25\text{V}$ ). Note the exact value. If the second voltage is not exactly one-half of the first voltage, adjust trimpot D and repeat *both* measurements ( $5\Omega$  and  $2.5\Omega$ ) again. Repeat as required.

## STEP 2 - HIGH-CURRENT OUTPUT IMPEDANCE ADJUSTMENT

To adjust the output impedance in the high-current range, connect a 20W,  $3.0\Omega$  load to the output. Set the output amplitude to 1 A and observe the load voltage on an oscilloscope. The load voltage should have an amplitude of approximately 5V (i.e.  $1\text{A} \times 5\Omega = 5\text{V}$ ). Note the exact value. Now replace the  $5.0\Omega$  load with a  $2.5\Omega$  load. The load voltage should fall by to approximately 2.5V (i.e.  $1\text{A} \times 2.5\Omega = 2.5\text{V}$ ). Note the exact value. If the second voltage is not exactly one-half of the first voltage, adjust trimpot D and repeat *both* measurements ( $5\Omega$  and  $2.5\Omega$ ) again. Repeat as required.

## STEP 3 - NULL AMPLITUDE-INDEPENDENT OFFSET

Connect a  $5.0\Omega$  load to the output of the instrument. Set the instrument amplitude and offset to zero, and turn on the output. A voltage of zero should be observed across the load. If a small positive constant DC offset is observed (on the order of several millivolts), adjust trimpot B until it is just removed. Do not adjust it further.

## STEP 4 - NULL AMPLITUDE-DEPENDENT OFFSET

Connect a  $5.0\Omega$  load to the output of the instrument. Set the instrument amplitude to zero, and turn on the output. Set the offset to 0 mA, and the amplitude to 1A. There should be no offset present on the waveform. If there is any DC offset, adjust trimpot A until it is removed.

## STEP 5 - ADJUST AMPLITUDE CALIBRATION

Set the instrument to operate with typical timing parameters into a test load of known resistance (between 1 and 5 Ohms). Set the output to "on", and set the amplitude to zero.

Send the query, "diag:ampl:cal:point? max" to the instrument, via the GPIB or RS-232 interfaces. Note the returned value. This is the number of amplitude calibration points stored in the instrument.

Calibration point 1 is always zero, so it can be skipped. Send the command "diag:ampl:cal:point 2 go" and measure the resulting output current amplitude. Record this value. The nominal amplitude will be displayed on the LCD display, and can be retrieved using the "curr?" command.

Update the calibration by sending the command "diag:ampl:cal:point 2 xxxx", where "xxxx" is the measured current in amps. For instance, if the measured amplitude is 5.4mA, send "diag:ampl:cal:point 2 0.0054". Note that the instrument will reject calibration changes of more than 20%. If the calibration has changed more than this, repeat this command several times, implementing a small step each time.

Repeat steps 4 and 5 for the remaining calibration points, replacing the "2" in the above commands with the calibration point number (3, 4, 5...).

#### STEP 6 - ADJUST OFFSET CALIBRATION

Set the instrument to operate with typical timing parameters into a test load of known resistance (between 1 and 5 Ohms). Set the output to "on", and set the amplitude to zero.

Send the query, "diag:offset:cal:point? max" to the instrument, via the GPIB or RS-232 interfaces. Note the returned value. This is the number of offset calibration points stored in the instrument.

Calibration point 1 is always zero, so it can be skipped. Send the command "diag:offset:cal:point 2 go" and measure the resulting output current amplitude. Record this value. The nominal amplitude will be displayed on the LCD display, and can be retrieved using the "curr:low?" command.

Update the calibration by sending the command "diag:offset:cal:point 2 xxxx", where "xxxx" is the measured current in amps. For instance, if the measured amplitude is 340mA, send "diag:offset:cal:point 2 0.340". Note that the instrument will reject calibration changes of more than 20%. If the calibration has changed more than this, repeat this command several times, implementing a small step each time.

Repeat steps 4 and 5 for the remaining calibration points (if any), replacing the "2" in the above commands with the calibration point number (3, 4, 5...).

#### STEP 7 - ADJUST MONITOR OUTPUT CALIBRATION

Set the instrument to operate with typical timing parameters into a test load of known resistance (between 1 and 5 Ohms). Set the output to "on", and set the amplitude to 1A. Observe the waveform on the rear-panel monitor output. The monitor output is nominally related to the main current output by  $V_{MON} = 1 \text{ V/A} \times I_{OUT}$ , so a pulse amplitude of 1.0V should be observed on the monitor waveform. If it not 1.0V, adjust trimpot E until it is.

### STEP 8 - ADJUST LOW-CURRENT LCD MONITOR CALIBRATION

Set the instrument to operate with typical timing parameters into a test load of known resistance (between 1 and 5 Ohms). Set the output to "on", and set the amplitude to 100 mA. Observe the monitor reading on the front panel display, or query the instrument using the "meas:ampl?" command. The returned value should be  $100 \text{ mA} \pm 10 \text{ mA}$ . If it is not, send the command "diag:mon:cal 0.1" and the monitor will be re-scaled.

### STEP 9 - ADJUST HIGH-CURRENT LCD MONITOR CALIBRATION

Set the instrument to operate with typical timing parameters into a test load of known resistance (between 1 and 5 Ohms). Set the output to "on", and set the amplitude to 1A. Observe the monitor reading on the front panel display, or query the instrument using the "meas:ampl?" command. The returned value should be  $1.0 \text{ A} \pm 0.01 \text{ A}$ . If it is not, send the command "diag:mon:cal 1" and the monitor will be re-scaled.

This completes the amplitude calibration procedure.

### OTHER CALIBRATION PROCEDURES

The timebase of the instrument can also be calibrated, if required. See Avtech Technical Brief 4, "How Can I Calibrate the Timebase of my Avtech Pulse Generator?" on the web at <http://www.avtechpulse.com/appnote/techbrief4/> for more information and sample LabView drivers.

## PROGRAMMING YOUR PULSE GENERATOR

### KEY PROGRAMMING COMMANDS

The "OP1B Interface Programming Manual" describes in detail how to connect the pulse generator to your computer, and the programming commands themselves. A large number of commands are available; however, normally you will only need a few of these. Here is a basic sample sequence of commands that might be sent to the instrument after power-up, using the internal trigger source:

*rst	(resets the instrument)
trigger:source internal	(selects internal triggering)
frequency 1 Hz	(sets the frequency to 1 Hz)
pulse:width 1 ms	(sets the pulse width to 1 ms)
pulse:delay 10 ms	(sets the delay to 10 ms)
output on	(turns on the output)
source:current 0.5 A	(sets the current amplitude to 0.5 amperes)
source:current:low 0.2 A	(sets the DC offset to 0.2 amperes)
measure:amplitude?	(this returns the peak current, in amperes, as measured by the monitor circuit)

For triggering a single event, this sequence would be more appropriate:

*rst	(resets the instrument)
trigger:source hold	(turns off all triggering)
pulse:width 1 ms	(sets the pulse width to 1 ms)
pulse:delay 10 ms	(sets the delay to 10 ms)
output on	(turns on the output)
source:current 0.5 A	(sets the current amplitude to 0.5 amperes)
source:current:low 0.2 A	(sets the DC offset to 0.2 amperes)
trigger:source immediate	(generates a single non-repetitive trigger event)
trigger:source hold	(turns off all triggering)
output off	(turns off both outputs)

These commands will satisfy 90% of your programming needs.



## ALL PROGRAMMING COMMANDS

For more advanced programmers, a complete list of the available commands is given below. These commands are described in detail in the "OP1B Interface Programming Manual". (Note: this manual also includes some commands that are not implemented in this instrument. They can be ignored.)

<u>Keyword</u>	<u>Parameter</u>	<u>Notes</u>
DIAGnostic:		
:AMPLitude		
:CALibration		
:POINT	<numeric value> <numeric value>	
:MONitor		
:CALibration	<numeric value>	[no query form]
:STEP	<numeric value>	
:OFFSet		
:CALibration		
:POINT	<numeric value> <numeric value>	
LOCAL		
MEASure:		
:AMPLitude?		[query only]
OUTPut:		
:[STATE]	<boolean value>	
:PROTection		
:TRIPped?		[query only]
REMOTE		
[SOURce]:		
:CURRent		
[:LEVel]		
[:IMMediate]		
[:AMPLitude]	<numeric value>	
:LOW	<numeric value>	
:PROTection		
:TRIPped?		[query only]
[SOURce]:		
:FREQuency		
[:CW   FIXed]	<numeric value>	
[SOURce]:		
:FUNction		
:[SHAPe]	DC   PULSe	
[SOURce]:		
:PULSe		
:PERiod	<numeric value>	
:WIDTh	<numeric value>	
:DCYCLe	<numeric value>	
:HOLD	WIDTh   DCYCLe	
:DELay	<numeric value>	
:GATE		
:LEVel	High   Low	
:TYPE	ASYNc   SYNc	
:POLarity	NORMal   COMPliment   INVerted	
STATUS:		
:OPERation		
:[EVENT]?		[query only, always returns "0"]

:CONDition?		[query only, always returns "0"]
:ENABle	<numeric value>	[implemented but not useful]
:QUESTionable		
:[EVENT]?		[query only, always returns "0"]
:CONDition?		[query only, always returns "0"]
:ENABle	<numeric value>	[implemented but not useful]
SYSTem:		
:COMMunicate		
:GPIB		
:ADDReSS	<numeric value>	
:SERial		
:CONTrol		
:RTS	ON   IBFull   RFR	
:[RECeive]		
:BAUD	1200   2400   4800   9600	
:BITS	7   8	
:ECHO	<boolean value>	
:PARity		
:[TYPE]	EVEN   ODD   NONE	
:SBITS	1   2	
:ERRor		
:[NEXT]?		[query only]
:COUNT?		[query only]
:VERSion?		[query only]
TRIGger:		
:SOURce	INTernal   EXTernal   MANual   HOLD   IMMEDIATE	
*CLS		[no query form]
*ESE	<numeric value>	
*ESR?		[query only]
*IDN?		[query only]
*OPC		
*SAV	0   1   2   3	[no query form]
*RCL	0   1   2   3	[no query form]
*RST		[no query form]
*SRE	<numeric value>	
*STB?		[query only]
*TST?		[query only]
*WAI		[no query form]

## REGULAR MAINTENANCE

The fan grille, located on the bottom of the instrument, should be cleaned once a year so that it does not become blocked. To clean the grille, use a high-power vacuum cleaner.