



**AVTECH ELECTROSYSTEMS LTD.**

NANOSECOND WAVEFORM ELECTRONICS  
SINCE 1975

□ P.O. BOX 265  
OGDENSBURG, NY  
U.S.A. 13669-0265  
TEL: (315) 472-5270  
FAX: (613) 226-2802

TEL: 1-800-265-6681  
FAX: 1-800-561-1970

e-mail: [info@avtechpulse.com](mailto:info@avtechpulse.com)  
<http://www.avtechpulse.com>

□ P.O. BOX 5120 STN. F  
OTTAWA, ONTARIO  
CANADA K2C 3H4  
TEL: (613) 226-5772  
FAX: (613) 226-2802

**INSTRUCTIONS**

**MODEL AVR-3-B-P**

**0 TO +200 VOLTS,  
10 ns RISE AND FALL TIME  
PULSE GENERATOR**

**WITH IEEE 488.2 AND RS-232 CONTROL**

**SERIAL NUMBER: \_\_\_\_\_**

### WARRANTY

Avtech Electrosystems Ltd. warrants products of its manufacture to be free from defects in material and workmanship under conditions of normal use. If, within one year after delivery to the original owner, and after prepaid return by the original owner, this Avtech product is found to be defective, Avtech shall at its option repair or replace said defective item. This warranty does not apply to units which have been disassembled, modified or subjected to conditions exceeding the applicable specifications or ratings. This warranty is the extent of the obligation assumed by Avtech with respect to this product and no other warranty or guarantee is either expressed or implied.

### TECHNICAL SUPPORT

Phone: 613-226-5772 or 1-800-265-6681

Fax: 613-226-2802 or 1-800-561-1970

E-mail: [info@avtechpulse.com](mailto:info@avtechpulse.com)

World Wide Web: <http://www.avtechpulse.com>

## TABLE OF CONTENTS

<b>WARRANTY</b>	<b>2</b>
<b>TECHNICAL SUPPORT</b>	<b>2</b>
<b>TABLE OF CONTENTS</b>	<b>3</b>
<b>INTRODUCTION</b>	<b>4</b>
<b>SPECIFICATIONS</b>	<b>5</b>
<b>INSTALLATION</b>	<b>6</b>
<b>VISUAL CHECK</b>	<b>6</b>
<b>PLUGGING IN THE INSTRUMENT</b>	<b>6</b>
<b>FRONT PANEL CONTROLS</b>	<b>7</b>
<b>REAR PANEL CONTROLS</b>	<b>9</b>
<b>GENERAL INFORMATION</b>	<b>10</b>
<b>BASIC PULSE CONTROL</b>	<b>10</b>
<b>TRIGGER MODES</b>	<b>12</b>
<b>PULSE WIDTH MODES</b>	<b>12</b>
<b>GATING MODES</b>	<b>12</b>
<b>USING OSCILLOSCOPES</b>	<b>13</b>
<b>OUTPUT IMPEDANCE</b>	<b>13</b>
<b>TOP COVER REMOVAL</b>	<b>13</b>
<b>ELECTROMAGNETIC INTERFERENCE</b>	<b>13</b>
<b>RACK MOUNTING</b>	<b>14</b>
<b>OPERATIONAL CHECK</b>	<b>15</b>
<b>PROGRAMMING YOUR PULSE GENERATOR</b>	<b>17</b>
<b>KEY PROGRAMMING COMMANDS</b>	<b>17</b>
<b>ALL PROGRAMMING COMMANDS</b>	<b>18</b>
<b>SYSTEM BLOCK DIAGRAM AND REPAIR PROCEDURE</b>	<b>20</b>
<b>BASIC WIRING DIAGRAMS</b>	<b>21</b>
<b>PERFORMANCE CHECK SHEET</b>	<b>23</b>

## INTRODUCTION

The AVR-3-B-P is a high performance, GPIB and RS232-equipped instrument capable of 800 W peak pulse power at repetition rates up to 10 kHz. The output amplitude is variable up to +200 V into 50  $\Omega$ . Pulse delay, advance and width are variable up to 100  $\mu$ s. Rise and fall times are fixed at less than 10 ns. The AVR-3-B-P can be triggered internally, or triggered or gated by an external source. A front-panel pushbutton can also be used to trigger the instrument. The output pulse width can also be set to follow an input trigger pulse.

The AVR-3-B-P features front panel keyboard and adjust knob control of the output pulse parameters along with a four line by 40 character back-lit LCD display of the output amplitude, polarity, pulse width, pulse repetition frequency, source resistance and delay. The instrument includes memory to store up to four complete instrument setups. The operator may use the front panel or the computer interface to store a complete "snapshot" of all key instrument settings, and recall this setup at a later time.

The MOSFET output stages will safely withstand any combination of front panel control settings, output open or short circuits, and high duty cycles. An internal power supply monitor removes the power to the output stage for five seconds if an average power overload exists. After that time, the unit operates normally for one second, and if the overload condition persists, the power is cut again. This cycle repeats until the overload is removed. The instrument will operate with duty cycles up to 0.5%. The output stage will source up to 5 Amps (and will automatically shut down if the load current exceeds 5 Amps).

## SPECIFICATIONS

Model:	AVR-3-B-P
GPIB and RS-232 control:	Standard
Amplitude: ( $R_L \geq 50$ Ohms)	0 to 200 Volts
Rise time:	$\leq 10$ ns
Fall time:	$\leq 10$ ns
Pulse width:	100 ns to 100 $\mu$ s
PRF:	0 to 10 kHz
Duty cycle (max):	0.5%
Average power out (max):	4 Watts
Polarity:	Positive
Propagation delay:	$\leq 100$ ns (Ext trig in to pulse out)
Jitter (Ext trig in to pulse out):	$\pm 100$ ps $\pm 0.03\%$ of sync delay
External Trigger:	Mode A: +5 Volt, 50 ns or wider (TTL) Mode B: +5 Volt, $PW_{IN} = PW_{OUT}$ (TTL)
Sync delay:	Variable 0 to $\pm 100$ $\mu$ s (sync out to pulse out)
Sync output:	+3 Volts, 200 ns, will drive 50 Ohm loads
Gated operation:	sync or async, active high or low, switchable
Connectors:	BNC
Power requirements:	120/240 Volts (switchable) 50 - 60 Hz
Dimensions: (H x W x D)	100 mm x 430 mm x 375 mm (3.9" x 17" x 14.8")
Chassis material:	cast aluminum frame and handles, blue vinyl on aluminum cover plates
Mounting:	Any
Temperature range:	+15° to +40° C

## INSTALLATION

### VISUAL CHECK

After unpacking the instrument, examine to ensure that it has not been damaged in shipment. Visually inspect all connectors, knobs, liquid crystal displays (LCDs), and the handles. Confirm that a power cord and two instrumentation manuals (this manual and the "OP1B Interface Programming Manual") are with the instrument. If the instrument has been damaged, file a claim immediately with the company that transported the instrument.

### PLUGGING IN THE INSTRUMENT

Examine the rear of the instrument. There will be a male power receptacle, a fuse holder and the edge of the power selector card visible. Confirm that the power selector is in the correct orientation - it should be marked either 120 or 240, indicating whether it expects 120V AC or 240V AC. If it is not set for the proper voltage, remove the fuse and then grasp the card with a pair of pliers and remove it. Rotate horizontally through 180 degrees. Reinstall the card and the correct fuse. In the 120V setting, a 1.0A slow blow fuse is required. In the 240V setting, a 1/2A slow blow fuse is required.

## FRONT PANEL CONTROLS

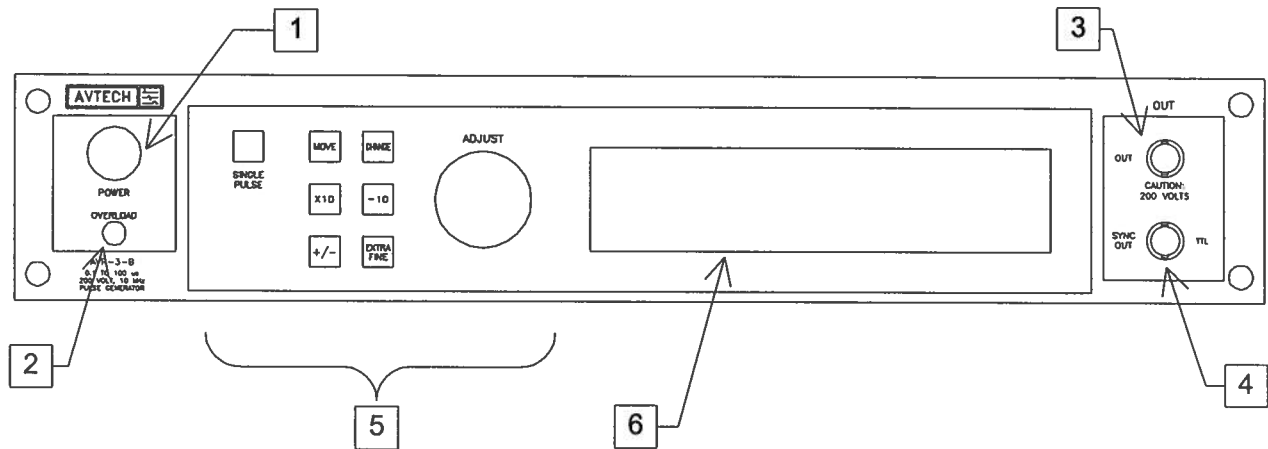

1. **POWER Switch.** The POWER push button switch applies AC prime power to the primaries of the transformer, turning the instrument on. The push button lamp (#382 type) is connected to the internal +15V DC supply.
2. **OVERLOAD.** The AVR-3-B-P is protected in its internal software against conflicting or dangerous settings. As an additional protective measure, an automatic overload circuit exists, which controls the front panel overload light. If the unit is overloaded (by operating at an exceedingly high duty cycle or by operating into a very low impedance), the protective circuit will turn the output of the instrument OFF and turn the indicator light ON. The light will stay ON (i.e. output OFF) for about 5 seconds after which the instrument will attempt to turn ON (i.e. light OFF) for about 1 second. If the overload condition persists, the instrument will turn OFF again (i.e. light ON) for another 5 seconds. If the overload condition has been removed, the instrument will turn on and resume normal operation.

This overload indicator may come on briefly at startup. This is not a cause for concern.

Note that the output stage will safely withstand a short circuited load condition.

3. **OUT CONNECTOR.** This BNC connector provides the main output signal, into load impedances of 50Ω or higher.
4. **SYNC OUT.** This connector supplies a SYNC output that can be used to trigger other equipment, particularly oscilloscopes. This signal leads (or lags) the main output by a duration set by the "DELAY" controls and has an approximate amplitude of +3 Volts to  $R_L > 1K$  with a pulse width of approximately 50 ns.

5. KEYPAD.

Control Name	Function
MOVE	This moves the arrow pointer on the display.
CHANGE	This is used to enter the submenu, or to select the operating mode, pointed to by the arrow pointer.
×10	If one of the adjustable numeric parameters is displayed, this increases the setting by a factor of ten.
÷10	If one of the adjustable numeric parameters is displayed, this decreases the setting by a factor of ten.
+/-	If one of the adjustable numeric parameters is displayed, and this parameter can be both positive or negative, this changes the sign of the parameter.
EXTRA FINE	This changes the step size of the ADJUST knob. In the extra-fine mode, the step size is twenty times finer than in the normal mode. This button switches between the two step sizes.
ADJUST	This large knob adjusts the value of any displayed numeric adjustable values, such as frequency, pulse width, etc. The adjust step size is set by the "EXTRA FINE" button.  When the main menu is displayed, this knob can be used to move the arrow pointer.

6. LIQUID CRYSTAL DISPLAY (LCD). This LCD is used in conjunction with the keypad to change the instrument settings. Normally, the main menu is displayed, which lists the key adjustable parameters and their current values. The "OP1B Interface Programming Manual" describes the menus and submenus in detail.



## REAR PANEL CONTROLS

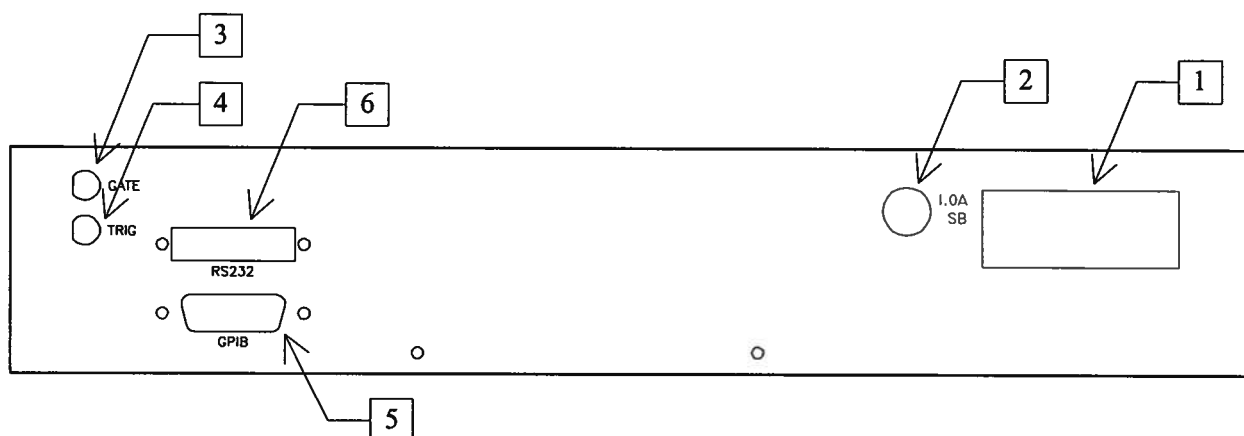

1. **AC POWER INPUT.** A three-pronged recessed male connector is provided on the back panel for AC power connection to the instrument. Also contained in this assembly is a 1.0A slow blow fuse and a removable card that can be removed and repositioned to switch between 120V AC in and 240V AC in.
2. **1.0A SB.** This fuse protects the output stage if the output duty cycle rating is exceeded.
3. **GATE.** This TTL-level (0 and +5V) logic input can be used to gate the triggering of the instrument. This input can be either active high or active low, depending on the front panel settings or programming commands. (The instrument triggers normally when this input is unconnected).
4. **TRIG.** This TTL-level (0 and +5V) logic input can be used to trigger the instrument, if the instrument is set to triggering externally. The instrument triggers on the rising edge of this input. The instrument can also be set such that the output pulse width tracks the pulse width on this input, or the output pulse width can be set independently.
5. **GPIB Connector.** A standard GPIB cable can be attached to this connector to allow the instrument to be computer-controlled. See the "OP1B Interface Programming Manual" for more details on GPIB control.
6. **RS-232 Connector.** A standard serial cable with a 25-pin male connector can be attached to this connector to allow the instrument to be computer-controlled. See the "OP1B Interface Programming Manual" for more details on RS-232 control.

## GENERAL INFORMATION

### BASIC PULSE CONTROL

This instrument can be triggered by its own internal clock or by an external TTL trigger signal. In either case, two output channels respond to the trigger: OUT and SYNC. The OUT channel is the signal that is applied to the load. Its amplitude and pulse width are variable. The SYNC pulse is a fixed-width TTL-level reference pulse used to trigger oscilloscopes or other measurement systems. When the delay is set to a positive value the SYNC pulse precedes the OUT pulse. When the delay is set to a negative value the SYNC pulse follows the OUT pulse.

These pulses are illustrated below, assuming internal triggering and a positive delay:

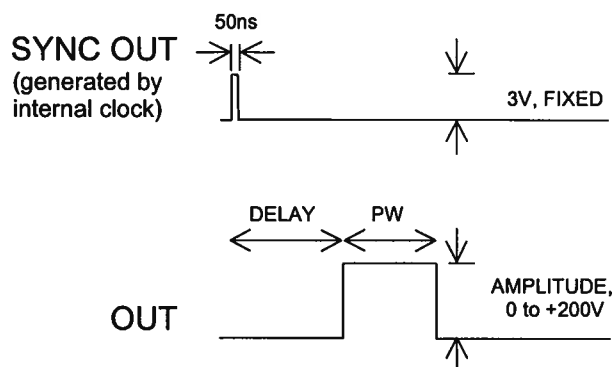

*Figure A*

If the delay is negative, the order of the SYNC and OUT pulses is reversed:

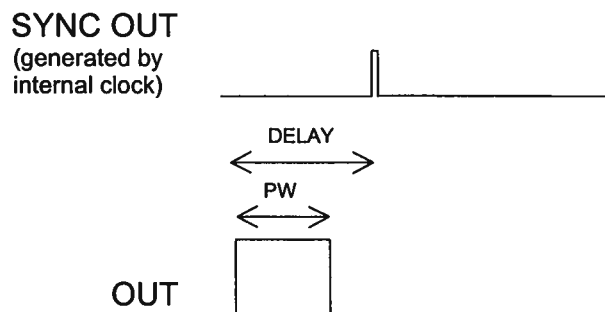

*Figure B*

The next figure illustrates the relationship between the signal when an external TTL-level trigger is used:

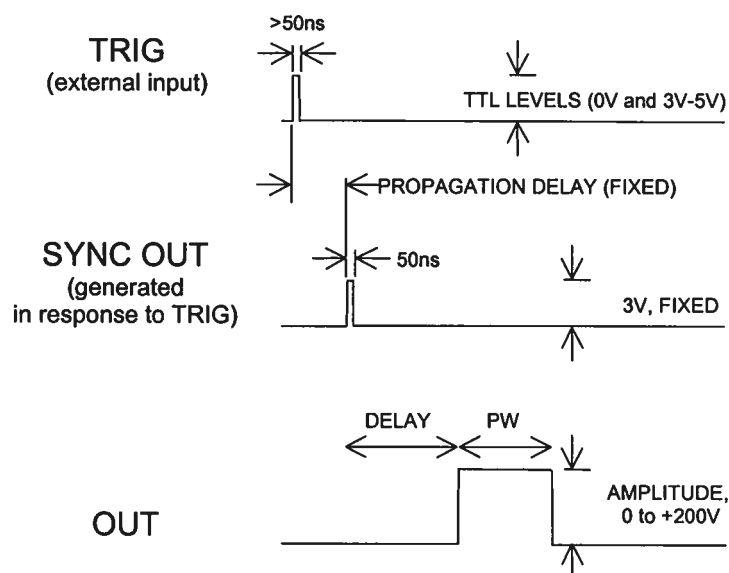

Figure C

As before, if the delay is negative, the order of the SYNC and OUT pulses is reversed.

The last figure illustrates the relationship between the signal when an external TTL-level trigger is used in the  $PW_{IN}=PW_{OUT}$  mode. In this case, the output pulse width equals the external trigger's pulse width (approximately), and the delay circuit is bypassed:

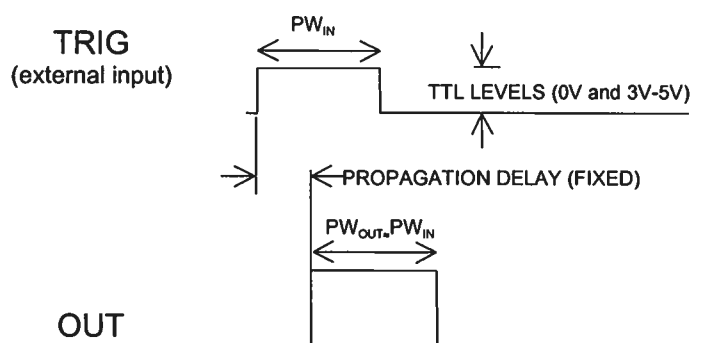

Figure D

The delay, pulse width, and frequency (when in the internal mode), of the OUT pulse can be varied with front panel controls or via the GPIB or RS-232 computer interfaces.

## TRIGGER MODES

This instrument has four trigger modes:

- **Internal Trigger:** the instrument controls the trigger frequency, and generates the clock internally.
- **External Trigger:** the instrument is triggered by an external TTL-level clock on the back-panel TRIG connector.
- **Manual Trigger:** the instrument is triggered by the front-panel “SINGLE PULSE” pushbutton.
- **Hold Trigger:** the instrument is set to not trigger at all.

These modes can be selected using the front panel trigger menu, or by using the appropriate programming commands. (See the “OP1B Interface Programming Manual” for more details.)

## PULSE WIDTH MODES

This instrument has two pulse width modes:

- **Normal:** the instrument controls the output pulse width.
- **$PW_{IN}=PW_{OUT}$ :** the output pulse width equals the pulse width of the trigger signal on the “TRIG” connector. The instrument must be in the external trigger mode.

These modes can be selected using the front panel pulse width menu, or by using the appropriate programming commands. (See the “OP1B Interface Programming Manual” for more details.)

## GATING MODES

Triggering can be suppressed by a TTL-level signal on the rear-panel GATE connector. The instrument can be set to stop triggering when this input high or low, using the front-panel gate menu or the appropriate programming commands. This input can also be set to act synchronously or asynchronously. When set to asynchronous mode, the GATE will disable the output immediately. Output pulses may be truncated. When set to synchronous mode, the output will complete the full pulse width if the output is high, and then stop triggering. No pulses are truncated in this mode.

## USING OSCILLOSCOPES

The bandwidth capability of components and instruments used to display the pulse generator output signal (attenuators, cables, connectors, etc.) should exceed 100 MHz.

When using a sampling oscilloscope, placing a 60 dB attenuator at the scope input will ensure a peak input signal to the scope of less than 1 Volt. This may be required to prevent damage to the input.

If a high impedance real time scope is used, the pulse generator output should be terminated using a shunt 50 Ohm resistor.

## OUTPUT IMPEDANCE

The AVR-3 features an output impedance of the order of several ohms (rather than 50 Ohms). The following consequences of this feature should be noted:

- When used to switch some semiconductor devices (eg. bipolar and VMOS power transistors), the AVR unit will yield much faster switching times than those provided by 50 Ohm pulse generators.
- The AVR unit will safely operate in to load impedances in the range of 50 ohms to an open circuit. However, the fall time may degrade for load impedances higher than fifty ohms, and severe ringing and overshoot may be observed.
- The AVR unit may be effectively converted to a fifty ohm output impedance generator by placing a fifty ohm ½ watt carbon composition resistor in series with the output of the unit and the load. The maximum available load voltage will then decrease to 100 volts (from 200 volts).

## TOP COVER REMOVAL

The interior of the instrument may be accessed by removing the four Phillips screws on the top panel. With the four screws removed, the top cover may be slid back (and off).

## ELECTROMAGNETIC INTERFERENCE

To prevent electromagnetic interference with other equipment, all used outputs should be connected to shielded 50Ω loads using shielded 50Ω coaxial cables. Unused outputs should be terminated with shielded 50Ω BNC terminators or with shielded BNC dust caps, to prevent unintentional electromagnetic radiation. All cords and cables should be less than 3m in length.

## RACK MOUNTING

A rack mounting kit is available. The -R5 rack mount kit may be installed after first removing the one Phillips screw on the side panel adjacent to the front handle.

## OPERATIONAL CHECK

This section describes a sequence to confirm the basic operation of the instrument. It should be performed after receiving the instrument. It is a useful learning exercise as well.

Before proceeding with this procedure, finish reading this instruction manual thoroughly. Then read the "Local Control" section of the "OP1B Interface Programming Manual" thoroughly. The "Local Control" section describes the front panel controls used in this operational check - in particular, the MOVE, CHANGE, and ADJUST controls.

1. Connect a cable from the SYNC OUT connector to the TRIG input of an oscilloscope. Connect a 10W (or higher) 50 $\Omega$  load to the OUT connector and place the scope probe across this load. Set the oscilloscope to trigger externally with the vertical setting at 5 Volts/div and the horizontal setting at 1 us/div.
2. Turn on the AVR-3-B-P. The main menu will appear on the LCD.
3. To set the AVR-3-B-P to trigger from the internal clock at a PRF of 1 kHz:
  - a) The arrow pointer should be pointing at the frequency menu item. If it is not, press the MOVE button until it is.
  - b) Press the CHANGE button. The frequency submenu will appear. Rotate the ADJUST knob until the frequency is set at 1 kHz.
  - c) The arrow pointer should be pointing at the "Internal" choice. If it is not, press MOVE until it is.
  - d) Press CHANGE to return to the main menu.
4. To set the delay to 1  $\mu$ s:
  - a) Press the MOVE button until the arrow pointer is pointing at the delay menu item.
  - b) Press the CHANGE button. The delay submenu will appear. Rotate the ADJUST knob until the delay is set at 1  $\mu$ s.
  - c) The arrow pointer should be pointing at the "Normal" choice. If it is not, press MOVE until it is.
  - d) Press CHANGE to return to the main menu.

5. To set the pulse width to 1  $\mu\text{s}$ :
  - a) Press the MOVE button until the arrow pointer is pointing at the pulse width menu item.
  - b) Press the CHANGE button. The pulse width submenu will appear. Rotate the ADJUST knob until the pulse width is set at 1  $\mu\text{s}$ .
  - c) The arrow pointer should be pointing at the "Normal" choice. If it is not, press MOVE until it is.
  - d) Press CHANGE to return to the main menu.
6. At this point, nothing should appear on the oscilloscope.
7. To enable the output:
  - a) Press the MOVE button until the arrow pointer is pointing at the output menu item.
  - b) Press the CHANGE button. The output submenu will appear.
  - c) Press MOVE until the arrow pointer is pointing at the "ON" choice.
  - d) Press CHANGE to return to the main menu.
8. To change the output amplitude:
  - a) Press the MOVE button until the arrow pointer is pointing at the amplitude menu item.
  - b) Press the CHANGE button. The amplitude submenu will appear. Rotate the ADJUST knob until the amplitude is set at 50V.
  - c) Observe the oscilloscope. You should see 1  $\mu\text{s}$  wide, 50V pulses.
  - d) Rotate the ADJUST knob. The amplitude as seen on the oscilloscope should vary. Set it at 200V.
  - e) Press CHANGE to return to the main menu.
9. Try varying the pulse width, by repeating step (5). As you rotate the ADJUST knob, the pulse width on the oscilloscope will change. It should agree with the displayed value. Stay below 0.5% duty cycle.

This completes the operational check.



## PROGRAMMING YOUR PULSE GENERATOR

### KEY PROGRAMMING COMMANDS

The “OP1B Interface Programming Manual” describes in detail how to connect the pulse generator to your computer, and the programming commands themselves. A large number of commands are available; however, normally you will only need a few of these. Here is a basic sample sequence of commands that might be sent to the instrument after power-up:

```
*rst                (resets the instrument)
trigger:source internal (selects internal triggering)
frequency 1000 Hz    (sets the frequency to 1000 Hz)
pulse:width 1 us     (sets the pulse width to 1 us)
pulse:delay 1 us     (sets the delay to 1 us)
volt 50              (sets the amplitude to 50 V)
output on            (turns on the output)
```

For triggering a single event, this sequence would be more appropriate:

```
*rst                (resets the instrument)
trigger:source hold  (turns off all triggering)
pulse:width 500 ns   (sets the pulse width to 500 ns)
output on            (turns on the output)
volt:ampl +50        (sets the amplitude to 50 V)
trigger:source immediate (generates a single non-repetitive trigger event)
trigger:source hold  (turns off all triggering)
output off           (turns off the output)
```

To set the instrument to trigger from an external TTL signal applied to the rear-panel TRIG connector, use:

```
*rst                (resets the instrument)
trigger:source external (selects external triggering)
pulse:width 500 ns     (sets the pulse width to 500 ns)
pulse:delay 1 us       (sets the delay to 1 us)
volt:ampl 190V         (sets the amplitude to 190 V)
output on              (turns on the output)
```

These commands will satisfy 90% of your programming needs.

## ALL PROGRAMMING COMMANDS

For more advanced programmers, a complete list of the available commands is given below. These commands are described in detail in the “OP1B Interface Programming Manual”. (Note: this manual also includes some commands that are not implemented in this instrument. They can be ignored.)

<u>Keyword</u>	<u>Parameter</u>	<u>Notes</u>
LOCAL		
OUTPut:		
:[STATe]	<boolean value>	
:PROTection		
:TRIPped?		[query only]
REMOTE		
[SOURce]:		
:FREQUency		
[:CW   FIXed]	<numeric value>	
[SOURce]:		
:PULSe		
:PERiod	<numeric value>	
:WIDTh	<numeric value>   IN	
:DCYCLe	<numeric value>	
:HOLD	WIDTh   DCYCLe	
:DELay	<numeric value>	
:GATE		
:TYPE	ASYNc   SYNc	
:LEVel	HIGH   LOW	
[SOURce]:		
:VOLTage		
[:LEVel]		
[:IMMediate]		
[:AMPLitude]	<numeric value>   EXTeRnal	
:PROTection		
:TRIPped?		[query only]
STATUS:		
:OPERation		
:[EVENt]?		[query only, always returns "0"]
:CONDition?		[query only, always returns "0"]
:ENABle	<numeric value>	[implemented but not useful]
:QUEStionable		
:[EVENt]?		[query only, always returns "0"]
:CONDition?		[query only, always returns "0"]
:ENABle	<numeric value>	[implemented but not useful]
SYSTEM:		
:COMMunicate		
:GPIB		
:ADDReSS	<numeric value>	
:SERial		
:CONTRol		
:RTS	ON   IBFull   RFR	
:[RECeive]		
:BAUD	1200   2400   4800   9600	
:BITS	7   8	

:ECHO	<boolean value>	
:PARity		
:[TYPE]	EVEN   ODD   NONE	
:SBITS	1   2	
:ERRor		
:[NEXT]?		[query only]
:COUNT?		[query only]
:VERSion?		[query only]
TRIGger:		
:SOURce	INTernal   EXTernal   MANual   HOLD   IMMEDIATE	
*CLS		[no query form]
*ESE	<numeric value>	
*ESR?		[query only]
*IDN?		[query only]
*OPC		
*SAV	0   1   2   3	[no query form]
*RCL	0   1   2   3	[no query form]
*RST		[no query form]
*SRE	<numeric value>	
*STB?		[query only]
*TST?		[query only]
*WAI		[no query form]

## SYSTEM BLOCK DIAGRAM AND REPAIR PROCEDURE

Besides the 60 Hz power supply, the AVR-3-B-P consists of the following basic components:

- AVR-3-PG-P pulse generator module
- OP1B timing and interface board
- 1/4A24-P20 Ultravolt power supply

The modules are interconnected as shown in the attached wiring diagram.

If the unit malfunctions, disconnect from the 60 Hz supply and the trigger source and remove the four screws on the top cover of the unit. With the screws removed, the top cover may be slid off.

Reconnect to the 60 Hz source and check the voltage on the line connecting to the +24V pin of the AVR-PG module. A voltage of +24 Volts should be recorded. If the voltage is substantially less than +24 Volts, disconnect the 60 Hz source and disconnect the wire feeding this terminal. Connect a 50 Ohm, 8 Watt between this wire and ground. Reconnect to the 60 Hz source and measure the voltage across this resistor. A voltage of +24 Volts should be observed. If the voltage is substantially less than 24 Volts the 60 Hz power supply is defective and should be either repaired or replaced.

If the measured voltage is equal to +24 Volts then the SL4H switching elements in the AVR-3-PG-P module have probably failed. The SL4H switching elements are easily replaced by removing the cover plate on the instrument bottom side and extracting the SL4H switching elements from their sockets using a pair of needle nose pliers. Before attempting this first insure that the prime power is off and also briefly ground the metal tabs on the SL4H elements to the chassis as the bypass capacitors may be charged to 225 Volts. Replacement SL4H units must be ordered directly from Avtech. When reinstalling the SL4H units in their sockets, insure that the shortest of the three terminals is adjacent to the black dot on the chassis.

**BASIC WIRING DIAGRAMS**

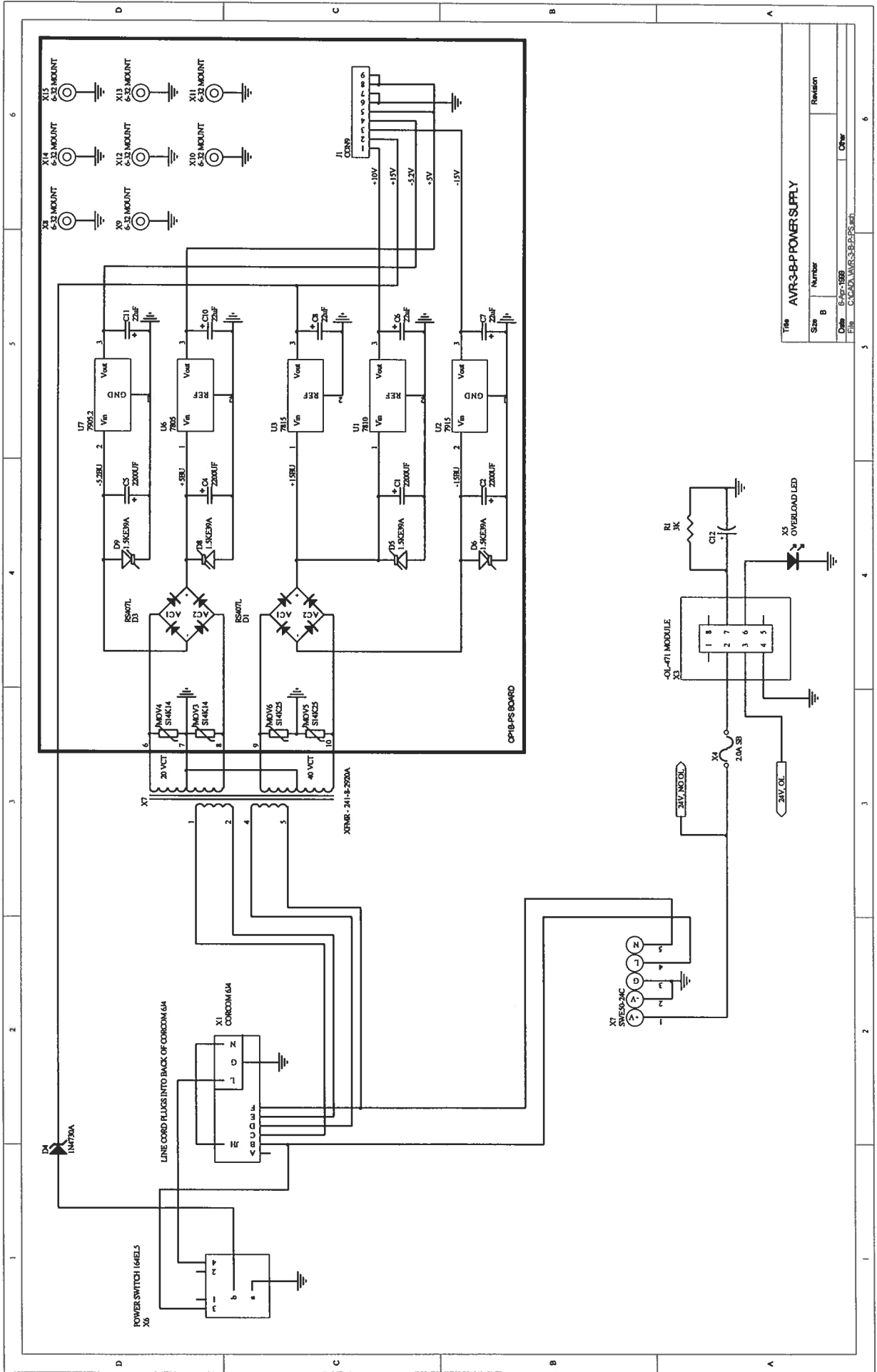

Title		AVR-3-B-P POWER SUPPLY	
Size	B	Number	
Date	8-26-1989	Revision	
File	C:\CADD\AVR-3-B-P.SCH	Other	



PERFORMANCE CHECK SHEET

UPDATED/CREATED BY MJC April 6/99