



**AVTECH ELECTROSYSTEMS LTD.**

NANOSECOND WAVEFORM ELECTRONICS  
SINCE 1975

P.O. BOX 265  
OGDENSBURG, NY  
U.S.A. 13669-0265  
TEL: (315) 472-5270  
FAX: (613) 226-2802

TEL: 1-800-265-6681  
FAX: 1-800-561-1970

e-mail: [info@avtechpulse.com](mailto:info@avtechpulse.com)  
<http://www.avtechpulse.com>

P.O. BOX 5120 STN. F  
OTTAWA, ONTARIO  
CANADA K2C 3H4  
TEL: (613) 226-5772  
FAX: (613) 226-2802

## INSTRUCTIONS

**MODEL AVR-5B-B-N-LUB**

**0 TO -500 V, 1 kHz  
DUAL CHANNEL PULSE GENERATOR  
WITH IEEE 488.2 AND RS-232 CONTROL**

**SERIAL NUMBER: \_\_\_\_\_**

### WARRANTY

Avtech Electrosystems Ltd. warrants products of its manufacture to be free from defects in material and workmanship under conditions of normal use. If, within one year after delivery to the original owner, and after prepaid return by the original owner, this Avtech product is found to be defective, Avtech shall at its option repair or replace said defective item. This warranty does not apply to units which have been disassembled, modified or subjected to conditions exceeding the applicable specifications or ratings. This warranty is the extent of the obligation assumed by Avtech with respect to this product and no other warranty or guarantee is either expressed or implied.

### TECHNICAL SUPPORT

Phone: 613-226-5772 or 1-800-265-6681

Fax: 613-226-2802 or 1-800-561-1970

E-mail: [info@avtechpulse.com](mailto:info@avtechpulse.com)

World Wide Web: <http://www.avtechpulse.com>

TABLE OF CONTENTS

<b>WARRANTY</b>	<b>2</b>
<b>TECHNICAL SUPPORT</b>	<b>2</b>
<b>TABLE OF CONTENTS</b>	<b>3</b>
<b>INTRODUCTION</b>	<b>4</b>
<b>SPECIFICATIONS</b>	<b>5</b>
<b>INSTALLATION</b>	<b>6</b>
<b>VISUAL CHECK</b>	<b>6</b>
<b>PLUGGING IN THE INSTRUMENT</b>	<b>6</b>
<b>FRONT PANEL CONTROLS</b>	<b>7</b>
<b>REAR PANEL CONTROLS</b>	<b>9</b>
<b>GENERAL INFORMATION</b>	<b>10</b>
<b>BASIC PULSE CONTROL</b>	<b>10</b>
<b>TRIGGER MODES</b>	<b>11</b>
<b>GATING MODES</b>	<b>12</b>
<b>PREVENTING OUTPUT STAGE FAILURE</b>	<b>12</b>
<b>TOP COVER REMOVAL</b>	<b>12</b>
<b>ELECTROMAGNETIC INTERFERENCE</b>	<b>12</b>
<b>RACK MOUNTING</b>	<b>12</b>
<b>OPERATIONAL CHECK</b>	<b>13</b>
<b>PROGRAMMING YOUR PULSE GENERATOR</b>	<b>16</b>
<b>KEY PROGRAMMING COMMANDS</b>	<b>16</b>
<b>ALL PROGRAMMING COMMANDS</b>	<b>17</b>
<b>PERFORMANCE CHECK SHEET</b>	<b>19</b>

## INTRODUCTION

The AVR-5B-B-N-LUB is a high performance, GPIB and RS232-equipped instrument capable of generating 0 to -500V on two separate output channels at repetition rates up to 1 kHz, with pulse widths from 10  $\mu$ s to 2 seconds, and duty cycles up to 50%. Both outputs will operate into loads of 1 M $\Omega$  or higher, and capacitances of up to 100 pF. Rise and fall times are fixed at less than 200 ns.

The AVR-5B-B-N-LUB includes an internal trigger source, but it can also be triggered or gated by an external source. A front-panel pushbutton can also be used to trigger the instrument. Both output channels share a common trigger source, but the pulse width and amplitudes are independently controllable. The relative delay between the two channels can be adjusted from 0 to 2 seconds.

The AVR-5B-B-N-LUB features front panel keyboard and adjust knob control of the output pulse parameters along with a four line by 40 character back-lit LCD display of the output amplitude, pulse width, pulse repetition frequency, and delay. The instrument includes memory to store up to four complete instrument setups. The operator may use the front panel or the computer interface to store a complete "snapshot" of all key instrument settings, and recall this setup at a later time.

The instrument is protected against overload conditions (such as short circuits) by an automatic control circuit. An internal power supply monitor removes the power to the output stage for five seconds if an average power overload exists. After that time, the unit operates normally for one second, and if the overload condition persists, the power is cut again. This cycle repeats until the overload is removed.

This instrument has a 50 $\Omega$  output impedance, and thus will drive high impedance loads without severe ringing and overshoot. However, the output cable length should not exceed 2 meters, as this may result in a degradation of the rise time.

### SPECIFICATIONS

Model:	AVR-5B-B-N-LUB
Output channels:	Two
Amplitude:	0 to -500 Volts, to $R_L \geq 1 \text{ M}\Omega$ , $C < 100 \text{ pF}$
Pulse width:	10 $\mu\text{s}$ to 2 seconds
Rise time:	$\leq 200 \text{ ns}$
Fall time:	$\leq 200 \text{ ns}$
PRF:	0.1 Hz to 1 kHz
Max. duty cycle:	50%
Output impedance:	50 $\Omega$
Computer control:	GPIB and RS-232 interfaces included
Jitter:	$\pm 100 \text{ ps}$ (Ext trig in to pulse out)
Trigger required:	External trigger mode: +5 Volt, 50 ns or wider (TTL)
Inter-channel delay:	Variable 0 to 2 seconds
Sync output:	+ 3 Volts, 200 ns, will drive 50 Ohm loads
Connectors:	Out: SHV type, Trig: BNC, Sync: BNC, Gate: BNC
Power, AC:	120/240 Volts (switchable) 50 - 60 Hz
Dimensions:	Mainframe: 100 mm x 430 mm x 375 mm (3.9" x 17" x 14.8")
Chassis material:	anodized aluminum, with blue plastic trim
Mounting:	Any
Temperature range:	+ 15° to + 40° C

## INSTALLATION

### VISUAL CHECK

After unpacking the instrument mainframe and the output module, examine to ensure that they have not been damaged in shipment. Visually inspect all connectors, knobs, liquid crystal displays (LCDs), and the handles. Confirm that a power cord and two instrumentation manuals (this manual and the "OP1B Interface Programming Manual") are with the instrument. If the instrument has been damaged, file a claim immediately with the company that transported the instrument.

### PLUGGING IN THE INSTRUMENT

Examine the rear of the instrument. There will be a male power receptacle, a fuse holder and the edge of the power selector card visible. Confirm that the power selector is in the correct orientation - it should be marked either 120 or 240, indicating whether it expects 120V AC or 240V AC. If it is not set for the proper voltage, remove the fuse and then grasp the card with a pair of pliers and remove it. Rotate horizontally through 180 degrees. Reinstall the card and the correct fuse. In the 120V setting, a 1.0A slow blow fuse is required. In the 240V setting, a 0.5A slow blow fuse is required.

## FRONT PANEL CONTROLS

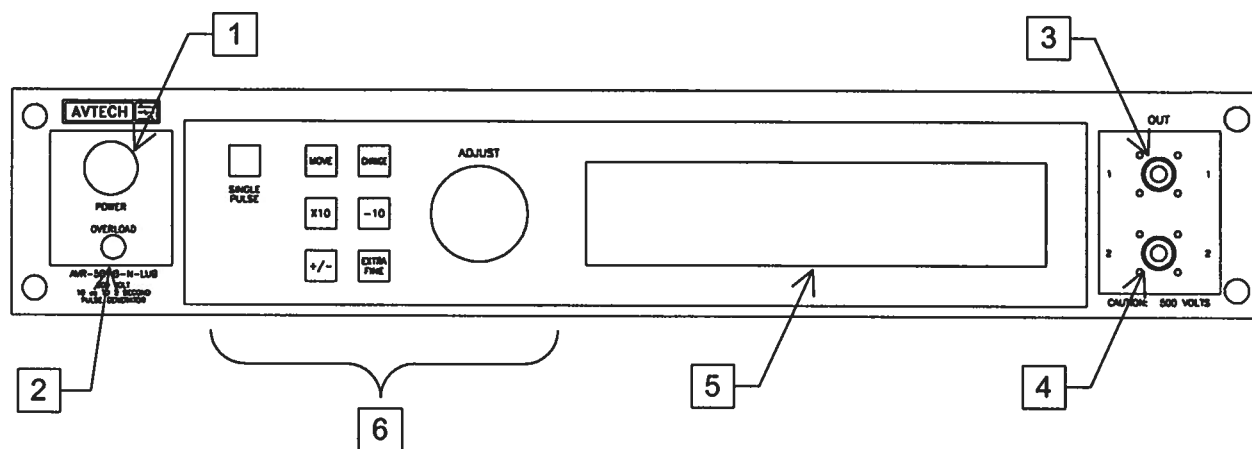

1. **POWER Switch.** The POWER push button switch applies AC prime power to the primaries of the transformer, turning the instrument on. The push button lamp (#382 type) is connected to the +15V DC supply.
2. **OVERLOAD.** The AVR-5B-B-N-LUB is protected in its internal software against conflicting or dangerous settings. As an additional protective measure, an automatic overload circuit exists, which controls the front panel overload light. If the unit is overloaded (by operating at an exceedingly high duty cycle or by operating into a very low impedance), the protective circuit will turn the output of the instrument OFF and turn the indicator light ON. The light will stay ON (i.e. output OFF) for about 5 seconds after which the instrument will attempt to turn ON (i.e. light OFF) for about 1 second. If the overload condition persists, the instrument will turn OFF again (i.e. light ON) for another 5 seconds. If the overload condition has been removed, the instrument will turn on and resume normal operation.

This overload indicator is only likely to come on in two situations:

- Briefly at startup. This is not a cause for concern.
- When a low-impedance load ( $R_L < 1M\Omega$ ), or a short-circuit, is connected to the output. In this case, turn off the instrument and connect the proper load.

Note that the output stage will safely withstand a short circuited load condition.

3. OUT 1 CONNECTOR. This SHV-type connector provides the Channel 1 output to a 1 M $\Omega$  (or higher) load.
4. OUT 2 CONNECTOR. This SHV-type connector provides the Channel 2 output to a 1 M $\Omega$  (or higher) load.
5. KEYPAD.

Control Name	Function
MOVE	This moves the arrow pointer on the display.
CHANGE	This is used to enter the submenu, or to select the operating mode, pointed to by the arrow pointer.
$\times 10$	If one of the adjustable numeric parameters is displayed, this increases the setting by a factor of ten.
$\div 10$	If one of the adjustable numeric parameters is displayed, this decreases the setting by a factor of ten.
+/-	If one of the adjustable numeric parameters is displayed, and this parameter can be both positive or negative, this changes the sign of the parameter.
EXTRA FINE	This changes the step size of the ADJUST knob. In the extra-fine mode, the step size is twenty times finer than in the normal mode. This button switches between the two step sizes.
ADJUST	This large knob adjusts the value of any displayed numeric adjustable values, such as frequency, pulse width, etc. The adjust step size is set by the "EXTRA FINE" button.  When the main menu is displayed, this knob can be used to move the arrow pointer.

6. LIQUID CRYSTAL DISPLAY (LCD). This LCD is used in conjunction with the keypad to change the instrument settings. Normally, the main menu is displayed, which lists the key adjustable parameters and their current values. The "OP1B Interface Programming Manual" describes the menus and submenus in detail.



## REAR PANEL CONTROLS

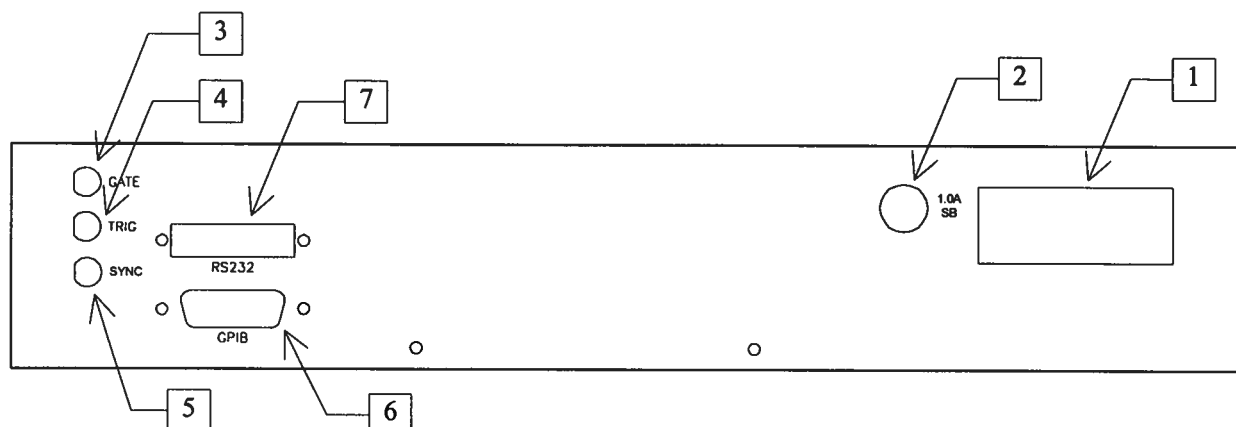

1. **AC POWER INPUT.** A three-pronged recessed male connector is provided on the back panel for AC power connection to the instrument. Also contained in this assembly is a 2.0A slow blow fuse and a removable card that can be removed and repositioned to switch between 120V AC in and 240V AC in.
2. **1.0A SB.** This fuse protects the output stage.
3. **GATE.** This TTL-level (0 and +5V) logic input can be used to gate the triggering of the instrument. This input can be either active high or active low, depending on the front panel settings or programming commands. (The instrument triggers normally when this input is unconnected).
4. **TRIG.** This TTL-level (0 and +5V) logic input can be used to trigger the instrument, if the instrument is set to triggering externally. The instrument triggers on the rising edge of this input.
5. **SYNC OUT.** This connector supplies a SYNC output that can be used to trigger other equipment, particularly oscilloscopes. This signal leads has an approximate amplitude of +3 Volts to  $R_L > 1 \text{ k}\Omega$  with a pulse width of approximately 200 ns.
6. **GPIB Connector.** A standard GPIB cable can be attached to this connector to allow the instrument to be computer-controlled. See the "OP1B Interface Programming Manual" for more details on GPIB control.
7. **RS-232 Connector.** A standard serial cable with a 25-pin male connector can be attached to this connector to allow the instrument to be computer-controlled. See the "OP1B Interface Programming Manual" for more details on RS-232 control.

## GENERAL INFORMATION

### BASIC PULSE CONTROL

This instrument can be triggered by several sources - its own internal clock, an external TTL trigger signal, the front-panel "SINGLE PULSE" pushbutton, or by a computer-generated command. In any case, three output channels respond to the trigger: OUT 1, OUT 2, and SYNC. OUT 1 and OUT 2 are the signals that are applied to the devices under test. Their amplitudes and pulse widths are variable. The SYNC pulse is a fixed-width TTL-level reference pulse used to trigger oscilloscopes or other measurement systems, and is coincident with the OUT 2 pulse. When the delay is set to a positive value the OUT 2 and SYNC pulses precede the channel 1 pulse. This order is reversed for negative delays.

These pulses are illustrated below for a positive delay:

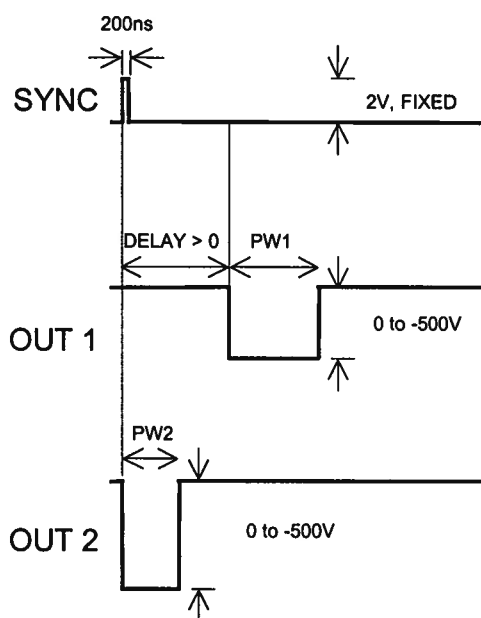

*Basic Output Pulses for Delay > 0*

The order of the output pulses is reversed for negative delays:

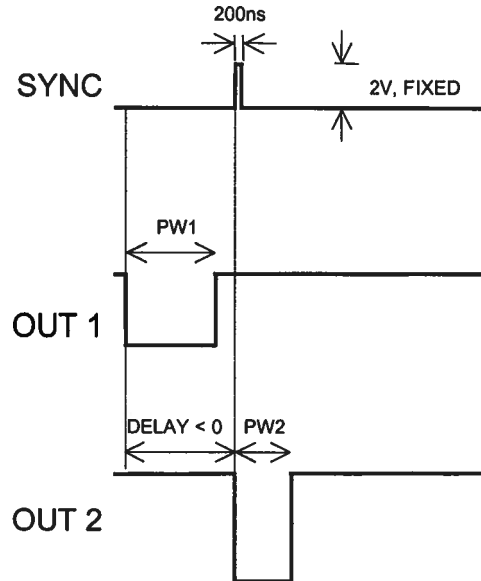

*Basic Output Pulses for Delay < 0*

The delay, pulse width, and frequency (when in the internal mode), of the OUT pulse can be varied with front panel controls or via the GPIB or RS-232 computer interfaces.

## TRIGGER MODES

This instrument has four trigger modes:

- **Internal Trigger:** the instrument controls the trigger frequency, and generates the clock internally.
- **External Trigger:** the instrument is triggered by an external TTL-level clock on the back-panel TRIG connector.
- **Manual Trigger:** the instrument is triggered by the front-panel "SINGLE PULSE" pushbutton.
- **Hold Trigger:** the instrument is set to not trigger at all.

These modes can be selected using the front panel trigger menu, or by using the appropriate programming commands. (See the "OP1B Interface Programming Manual" for more details.)

## GATING MODES

Triggering can be suppressed by a TTL-level signal on the rear-panel GATE connector. The instrument can be set to stop triggering when this input high or low, using the front-panel gate menu or the appropriate programming commands.

## PREVENTING OUTPUT STAGE FAILURE

The output stage is protected against overload condition by the overload module and a 1.0 A slow blow fuse on the main frame back panel. However, the output switching elements may fail if the unit is triggered at a PRF exceeding 1 kHz or at duty cycles exceeding 50%. Heating and subsequent possible failure of the output stage is reduced if the following action is taken where possible:

- PRF is kept to a minimum, i.e. operate in a low PRF range when possible rather than in a high PRF range.
- Keep the output PW to a minimum.
- Never apply an externally generated voltage to the output port.
- The load impedance must always exceed 1 M $\Omega$ .

## TOP COVER REMOVAL

The interior of the instrument may be accessed by removing the four Phillips screws on the top panel. With the four screws removed, the top cover may be slid back (and off).

## ELECTROMAGNETIC INTERFERENCE

To prevent electromagnetic interference with other equipment, all used outputs should be connected to shielded 50 $\Omega$  loads using shielded 50 $\Omega$  coaxial cables. Unused outputs should be terminated with shielded 50 $\Omega$  BNC terminators or with shielded BNC dust caps, to prevent unintentional electromagnetic radiation. All cords and cables should be less than 3m in length.

## RACK MOUNTING

A rack mounting kit is available. The -R5 rack mount kit may be installed after first removing the one Phillips screw on the side panel adjacent to the front handle.

## OPERATIONAL CHECK

This section describes a sequence to confirm the basic operation of the instrument. It should be performed after receiving the instrument. It is a useful learning exercise as well.

Before proceeding with this procedure, finish read this instruction manual thoroughly. Then read the "Local Control" section of the "OP1B Interface Programming Manual" thoroughly. The "Local Control" section describes the front panel controls used in this operational check - in particular, the MOVE, CHANGE, and ADJUST controls.

1. Connect a cable from the SYNC OUT connector to the TRIG input of an oscilloscope. Connect a 1/2W (or higher) 1M $\Omega$  load to the OUT 1 connector and place the scope probe across this load. The load resistor must have a voltage rating of at least 500V. The cable connecting the load to the output should be less than 2 meters in length, to avoid a degradation of the rise time. The load capacitance should not exceed 100 pF.
2. Set the oscilloscope to trigger externally with the vertical setting at 100 Volts/div and the horizontal setting at 10  $\mu$ s/div. Be sure that your oscilloscope and probe setup can handle the maximum amplitude of -500V. An attenuator might be necessary to avoid damaging the probe and oscilloscope.

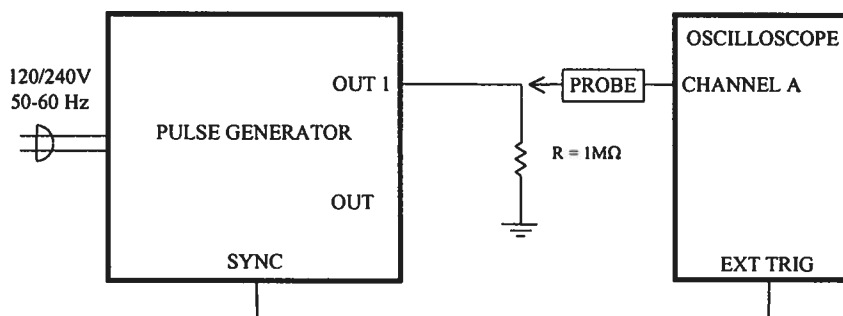

3. Turn on the AVR-5B-B-N-LUB. The main menu will appear on the LCD.
4. To set the AVR-5B-B-N-LUB to trigger from the internal clock at a PRF of 100 Hz:
  - The arrow pointer should be pointing at the frequency menu item. If it is not, press the MOVE button until it is.

- Press the CHANGE button. The frequency submenu will appear. Rotate the ADJUST knob until the frequency is set at 100 Hz.
  - The arrow pointer should be pointing at the “Internal” choice. If it is not, press MOVE until it is.
  - Press CHANGE to return to the main menu.
5. To set the delay to 20  $\mu\text{s}$ :
- Press the MOVE button until the arrow pointer is pointing at the delay menu item.
  - Press the CHANGE button. The delay submenu will appear. Rotate the ADJUST knob until the delay is set at 20  $\mu\text{s}$ .
  - Press CHANGE to return to the main menu.
6. To set the pulse width to 50  $\mu\text{s}$ :
- Press the MOVE button until the arrow pointer is pointing at the PW1 menu item.
  - Press the CHANGE button. The pulse width submenu will appear. Rotate the ADJUST knob until the pulse width is set at 50  $\mu\text{s}$ .
  - The arrow pointer should be pointing at the “Normal” choice. If it is not, press MOVE until it is.
  - Press CHANGE to return to the main menu.
7. At this point, nothing should appear on the oscilloscope.
8. To enable the output:
- Press the MOVE button until the arrow pointer is pointing at the output menu item.
  - Press the CHANGE button. The output submenu will appear.
  - Press MOVE until the arrow pointer is pointing at the “ON” choice.
  - Press CHANGE to return to the main menu.
9. To change the output amplitude:

- Press the MOVE button until the arrow pointer is pointing at the AMP1 menu item.
  - Press the CHANGE button. The amplitude submenu will appear. Rotate the ADJUST knob until the amplitude is set at -200V.
  - Observe the oscilloscope. You should see 50  $\mu$ s wide, -200V pulses.
  - Rotate the ADJUST knob. The amplitude as seen on the oscilloscope should vary.
  - Press CHANGE to return to the main menu.
10. Repeat step 9, but set the amplitude to zero.
11. To disable the output:
- Press the MOVE button until the arrow pointer is pointing at the output menu item.
  - Press the CHANGE button. The output submenu will appear.
  - Press MOVE until the arrow pointer is pointing at the "OFF" choice.
  - Press CHANGE to return to the main menu.
12. Remove the load from OUT 1 and connect it to OUT 2. Repeat steps 6-11, using the PW2 and AMP2 menus this time. This will test the second channel.
13. This completes the operational check.

## PROGRAMMING YOUR PULSE GENERATOR

### KEY PROGRAMMING COMMANDS

The “OP1B Interface Programming Manual” describes in detail how to connect the pulse generator to your computer, and the programming commands themselves. A large number of commands are available; however, normally you will only need a few of these. Here is a basic sample sequence of commands that might be sent to the instrument after power-up:

```
*rst                (resets the instrument)
trigger:source internal (selects internal triggering)
frequency 1000 Hz    (sets the frequency to 1000 Hz)
pulse:width1 100 us (sets the pulse width of channel 1 to 100 us)
pulse:width2 200 us (sets the pulse width of channel 2 to 200 us)
pulse:delay 3 us    (sets the inter-channel delay to 3 us)
volt1 -200          (sets the amplitude of channel 1 to -200 V)
volt2 -400          (sets the amplitude of channel 2 to -400 V)
output on           (turns on the output)
```

For triggering a single event, this sequence would be more appropriate:

```
*rst                (resets the instrument)
trigger:source hold  (turns off all triggering)
pulse:width1 100 us (sets the pulse width of channel 1 to 100 us)
pulse:width2 200 us (sets the pulse width of channel 2 to 200 us)
pulse:delay 3 us    (sets the inter-channel delay to 3 us)
output on           (turns on the output)
volt1 -200          (sets the amplitude of channel 1 to -200 V)
volt2 -400          (sets the amplitude of channel 2 to -400 V)
trigger:source immediate (generates a single non-repetitive trigger event)
trigger:source hold  (turns off all triggering)
output off          (turns off the output)
```

To set the instrument to trigger from an external TTL signal applied to the rear-panel TRIG connector, use:

```
*rst                (resets the instrument)
trigger:source external (selects external triggering)
pulse:width1 100 us   (sets the pulse width of channel 1 to 100 us)
pulse:width2 200 us   (sets the pulse width of channel 2 to 200 us)
pulse:delay 3 us      (sets the inter-channel delay to 3 us)
volt1 -200            (sets the amplitude of channel 1 to -200 V)
```



volt2 -400                                   (sets the amplitude of channel 2 to -400 V)  
output on                                   (turns on the output)

These commands will satisfy 90% of your programming needs.

## ALL PROGRAMMING COMMANDS

For more advanced programmers, a complete list of the available commands is given below. These commands are described in detail in the "OP1B Interface Programming Manual". (Note: this manual also includes some commands that are not implemented in this instrument. They can be ignored.)

Note that the pulse width and amplitude -related commands should be suffixed with the channel number, as illustrated in the previous section. If the suffix is not included, channel 1 will be assumed. The remaining commands will generate an error if a channel suffix is attached, since their effects are common to both channels.

<u>Keyword</u>	<u>Parameter</u>	<u>Notes</u>
LOCAL		
OUTPut:		
:[STATE]	<boolean value>	
:PROTection		
:TRIPped?		[query only]
REMOTE		
[SOURce]:		
:FREQuency		
[:CW   FIXed]	<numeric value>	
[SOURce]:		
:PULSe		
:PERiod	<numeric value>	
:WIDTh	<numeric value>	
:DCYClE	<numeric value>	
:HOLD	WIDTh   DCYClE	
:DELay	<numeric value>	
:GATE		
:LEVel	High   Low	
[SOURce]:		
:VOLTagE		
[:LEVel]		
[:IMMediate]		
[:AMPLitude]	<numeric value>   EXTernal	
:PROTection		
:TRIPped?		[query only]
STATUS:		
:OPERation		
:[EVENt]?		[query only, always returns "0"]
:CONDition?		[query only, always returns "0"]

:ENABLE	<numeric value>	[implemented but not useful]
:QUESTionable		
:[EVENT]?		[query only, always returns "0"]
:CONDition?		[query only, always returns "0"]
:ENABLE	<numeric value>	[implemented but not useful]
SYSTEM:		
:COMMunicate		
:GPIB		
:ADDRess	<numeric value>	
:SERial		
:CONTrol		
:RTS	ON   IBFull   RFR	
:[RECeive]		
:BAUD	1200   2400   4800   9600	
:BITS	7   8	
:ECHO	<boolean value>	
:PARity		
:[TYPE]	EVEN   ODD   NONE	
:SBITS	1   2	
:ERRor		
:[NEXT]?		[query only]
:COUNT?		[query only]
:VERSion?		[query only]
TRIGger:		
:SOURce	INTernal   EXTernal   MANual   HOLD   IMMEDIATE	
*CLS		[no query form]
*ESE	<numeric value>	
*ESR?		[query only]
*IDN?		[query only]
*OPC		
*SAV	0   1   2   3	[no query form]
*RCL	0   1   2   3	[no query form]
*RST		[no query form]
*SRE	<numeric value>	
*STB?		[query only]
*TST?		[query only]
*WAI		[no query form]

PERFORMANCE CHECK SHEET