



**AVTECH ELECTROSYSTEMS LTD.**

NANOSECOND WAVEFORM ELECTRONICS  
SINCE 1975

P.O. BOX 265  
OGDENSBURG, NY  
U.S.A. 13669-0265  
TEL: (315) 472-5270  
FAX: (613) 226-2802

TEL: 1-800-265-6681  
FAX: 1-800-561-1970  
U.S.A. & CANADA

e-mail: [info@avtechpulse.com](mailto:info@avtechpulse.com)

BOX 5120 STN. F  
OTTAWA, ONTARIO  
CANADA K2C 3H4  
TEL: (613) 226-5772  
FAX: (613) 226-2802

INSTRUCTIONS

MODEL AV-1010-C-MI PULSE GENERATOR

S.N. :

### WARRANTY

Avtech Electrosystems Ltd. warrants products of its manufacture to be free from defects in material and workmanship under conditions of normal use. If, within one year after delivery to the original owner, and after prepaid return by the original owner, this Avtech product is found to be defective, Avtech shall at its option repair or replace said defective item. This warranty does not apply to units which have been disassembled, modified or subjected to conditions exceeding the applicable specifications or ratings. This warranty is the extent of the obligation or liability assumed by Avtech with respect to this product and no other warranty or guarantee is either expressed or implied.

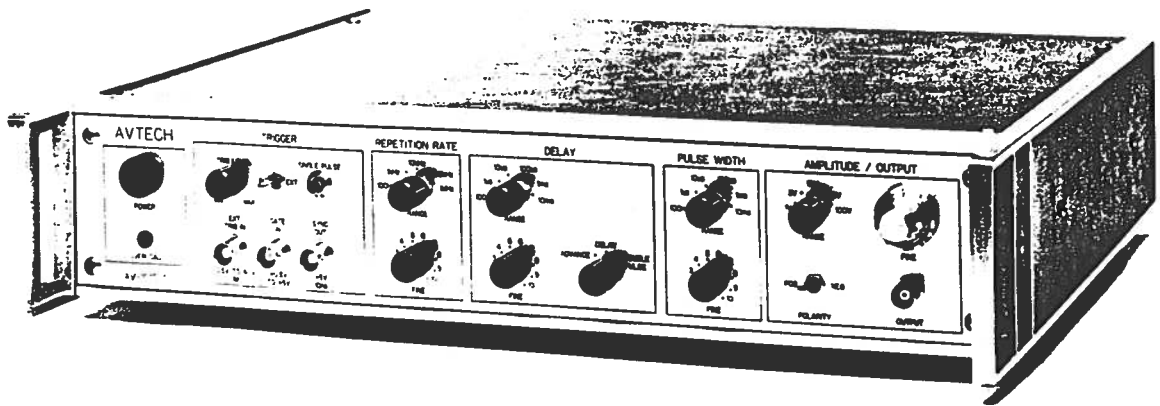

## INTRODUCTION

### MODEL AV-1010-C PULSE GENERATOR

The Model AV-1010-C is a high performance instrument capable of 200 W peak pulse power at repetition rates up to 1 MHz. The output polarity is selectable and the amplitude is variable up to 100 V into 50 Ohms. Pulse delay, advance and width are variable up to 10 ms. Rise and fall times are fixed at less than 15 ns. Model AV-1010-C provides single or double pulse output and can be triggered or gated by an external source. The output pulse width can be set to follow an input trigger pulse width and the output amplitude can be controlled by an externally applied 0 to +10 Volts DC control voltage.

## A) SPECIFICATIONS

Pulse output amplitude: <sup>1</sup>	0.3 V to 100 V (into 50 Ohms)	Range 1: 0.3 V to 1 V Range 2: 0.3 V to 3 V Range 3: 0.3 V to 10 V Range 4: 0.3 V to 30 V Range 5: 0.3 V to 100 V	Within each range, the amplitude is controlled by a 10 turn locking dial.
Output polarity:	Positive or negative (Front panel selector switch)		
Rise time, fall time:	≤ 15 ns		
Pulse aberrations:	≤ ± 5 % of amplitude		
Pulse width: <sup>2</sup>	50 ns to 10 ms (6-position range switch and a one-turn fine control) <sup>2</sup>		
Jitter:	Pulse Width: ≤ 0.1 %, (typically <0.01%) Delay/Advance: ≤ 0.1 %, +0.5 ns Period: ≤ 0.1 %, +0.5 ns		
Pulse repetition rate:	10 Hz to 1.0 MHz (5-position range switch and a one-turn fine control)		
Maximum duty cycle:	≥ 50%, for amplitudes between 0 V and 10 V ≥ 25%, for amplitudes between 10 V and 20 V ≥ 10%, for amplitudes between 20 V and 100 V		
Output impedance:	50 Ohms, in the 1 V, 3 V, 10 V, and 30 V ranges 2 Ohms in the 100 Volt range		
Minimum double pulse spacing:	100 ns		
Delayed and advanced pulse range:	0 to 10 ms, (between SYNC out and main pulse output)		
SYNC output:	+3 Volts, 50 ns (R <sub>L</sub> > 1 K)		
Gated operation:	Unit will trigger when a voltage between 500 mV and +5 V is applied to the Gate input (R <sub>IN</sub> = 50 Ω)		
External trigger:	The unit may be triggered by a signal source with:	Amplitude: ± 0.5 V to ± 40 V	Repetition rate: ≤ 1 MHz
			Pulse width: ≥ 50 ns
Minimum propagation delay external trigger modes:	Advance: 200 ns Delay: 300 ns Double pulse: 200 ns PW <sub>IN</sub> = PW <sub>OUT</sub> : 100 ns		
Output protection:	The output is protected against:	short circuits open circuits high duty cycle	
Connectors:	BNC female		
Power source:	120/240 Volts, ± 10 % (switchable) 48 Hz to 66 Hz, 100 VA maximum		
Dimensions (H x W x D):	100 mm x 430 mm x 375 mm (3.9" x 17" x 14.8")		
Weight:	≤ 10 Kg (22 lbs)		
Chassis material:	Aluminum. Anodized aluminum front panel with cast aluminum side panels (with blue-gray plastic trim) and aluminum top and bottom panels with blue-gray plastic trim.		
Operating temperature:	+10° C to +50° C		
Accessories furnished:	one 6' detachable power cord one operation-maintenance manual		
Option available:	19" rack mount kit		

1) The output amplitude may also be controlled by applying 0 to +10 Volts DC to a rear panel banana connector.

2) The output pulse width may also be controlled externally by applying a TTL level trigger of the desired width to a rear panel banana connector (PW<sub>IN</sub> = PW<sub>OUT</sub> mode).

## B) INSTALLATION

### VISUAL CHECK

After unpacking the instrument, examine to ensure that it has not been damaged in shipment. Visually inspect all connectors, knobs and the handles. Confirm that a power cord and instruction manual are with the instrument. (If the instrument has been damaged in shipment, file a claim immediately with the company that transported the instrument).

### PLUGGING IN THE INSTRUMENT

Examine the rear of the instrument. There will be a male power receptacle, a fuse holder and the edge of the power selector card will be visible. Confirm that the power selector is in the correct orientation - it should be marked either 120 or 240, indicating whether it expects 120V AC or 240V AC. If it is not set for the proper voltage, remove the fuse then grasp the card with a pair of pliers and remove it. Rotate horizontally through 180 degrees. Reinstall the card and the correct fuse. In the 120V setting, a 1/2A slow blow fuse is required. In the 240V setting, a 1/4A slow blow fuse is required.

### OPERATIONAL CHECK

This check is to confirm that the instrument is fully functional. Set the controls to the following values:

#### FRONT PANEL

INT/EXT Switch: INT position  
REPETITION RATE RANGE Switch: 10 kHz  
REPETITION RATE Vernier: MAX  
DELAY RANGE Switch: 1 us  
DELAY Vernier: MID range  
ADVANCE, DELAY, DOUBLE PULSE: DELAY  
PULSE WIDTH RANGE Switch: 1 us  
PULSE WIDTH Vernier: MAX  
POLARITY Switch: +  
AMPLITUDE RANGE Switch: 10V  
AMPLITUDE Vernier: MAX

## REAR PANEL

AMP: INT

PW: INT

HV: ON

Connect a cable from the SYNC OUT connector to the TRIG input of an oscilloscope. Connect a 2W (or higher) 50 Ohm load to the OUT connector and place the scope probe across this load.

Set the oscilloscope to trigger externally with the vertical setting at 5 Volts/div and the horizontal setting at 1 us/div. Then follow the instructions below and compare what is seen on the oscilloscope to what is described. Only approximate values are needed to confirm operation.

<u>STEP</u>	<u>CONTROL</u>	<u>OPERATION</u>	<u>RESULTS</u>
1	POWER	Push in (ON)	+10V pulses at the main output, with period 100 us, pulse width 1.0 us, < 15ns rise & fall times.
2	REPETITION RATE VERNIER	Rotate to MIN, then to MAX	Period rises to about 1 ms then falls to about 100 us.
3	DELAY VERNIER	Rotate to MAX, then to MIN	Pulses shift to the right on the oscilloscope by 1 us, then back.
4	PULSE WIDTH VERNIER	Rotate to MIN, then to MAX	Pulse width varies from 100 ns to 1.0 us.
5	POLARITY SWITCH	Switch to -, then to +	Pulse polarity becomes negative & then positive.
6	AMPLITUDE RANGE	Switch to 30 Volts and then to 100 Volts and then back to 10 Volts	The output pulse amplitude will jump to 30 Volts and then to 100 Volts. The voltage will then decay slowly to 10 Volts.

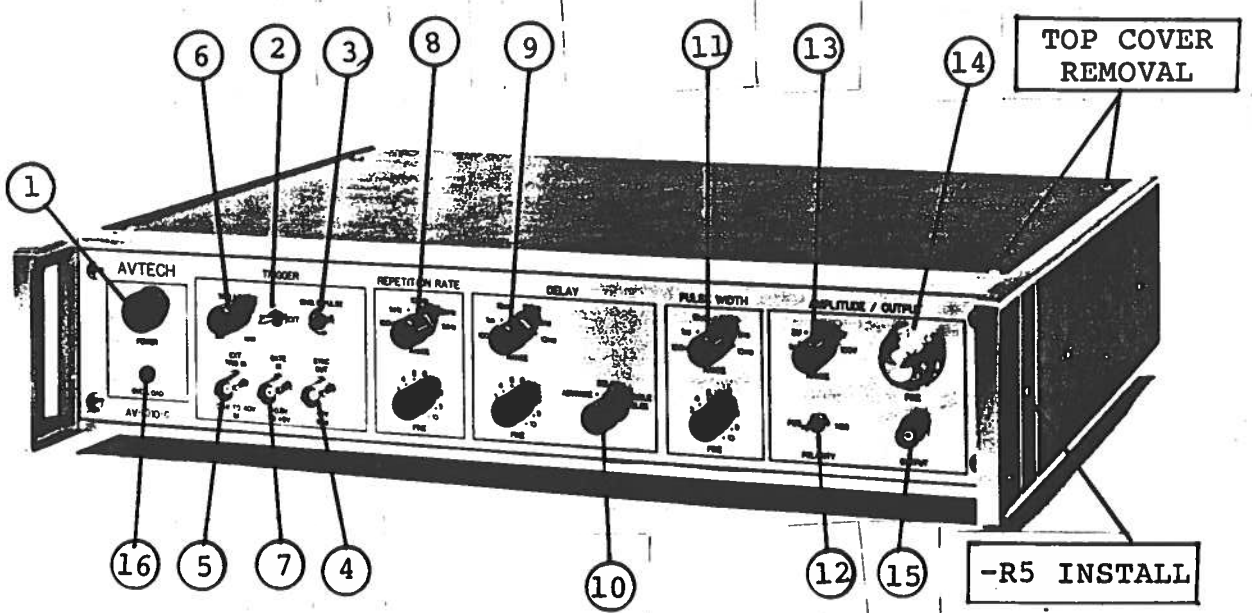

Fig. 1 Front panel controls

### C) FRONT PANEL CONTROLS

- (1) POWER Switch. The POWER push button switch applies AC prime power to the primaries of the transformer, turning the instrument on. The push button lamp (#382 type) is connected to the +15V DC supply.
- (2) INT/EXT Switch. In the "INT" position the instrument is internally triggered and the "SYNC OUT" connector provides a SYNC output which allows one to trigger other instruments, such as oscilloscopes. In the "EXT" position the instrument is triggered by a  $\pm 0.5V$  to  $\pm 40V$  50 ns (or wider) input pulse on the "TRIG IN" connector, or by pressing the "SINGLE PULSE" push button.
- (3) SINGLE PULSE Push Button. The "SINGLE PULSE" push button will trigger the instrument manually for one cycle of output, when the "INT/EXT" switch is in the "EXT" position. Otherwise, the push button has no effect.
- (4) SYNC OUT. When the "INT/EXT" switch is in the "INT" position, this connector supplies a SYNC output that can be used to trigger other equipment, particularly oscilloscopes. This signal leads, or lags, the main output by a duration set by the "DELAY" controls and has an approximate amplitude of +3 Volts to  $R_L > 1K$  with a pulse width of about 50 ns.
- (5) TRIG IN. When the "INT/EXT" switch is in the "EXT" position, the external trigger ( $\pm 0.5$  Volts to  $\pm 40$  Volts, PW 50 ns) is applied to this connector. This input presents a high impedance (1 M Ohm).
- (6) TRIGGER LEVEL. This one turn control varies the EXT trigger level from  $\pm 0.5$  Volts to  $\pm 40$  Volts.
- (7) GATE Input. The GATE input will suppress the triggering of the instrument if taken to a TTL HIGH level (i.e. 0.5 to 5.0V). If it is left open or taken to a TTL LOW, normal triggering will occur ( $R_{IN} = 1K$ ).
- (8) REPETITION RATE Controls. The rotary switch marked "RANGE" selects the pulse repetition rate for the internally triggered mode. The vernier (labeled "MIN-MAX") provides continuously variable control of each range. There are five ranges and the instrument is set to the rate indicated on the front panel when the vernier is in the "MAX" position.



10 Hz - 100 Hz  
100 Hz - 1 kHz  
1 kHz - 10 kHz  
10 kHz - 100 kHz  
100 kHz - 1.0 MHz

- (9) DELAY Controls. The rotary switch selects one of five ranges and the vernier provides continuously variable control of each range. The instrument is set to the delay indicated on the front panel when the vernier is in the "MAX" position.

100 ns - 1 us  
1 us - 10 us  
10 us - 100 us  
100 us - 1 ms  
1 ms - 10 ms

- (10) ADVANCE, DELAY, DOUBLE PULSE. With this three position switch in the ADVANCE position, the leading edge of the output pulse precedes the leading edge of the SYNC output. When in the DELAY position, the leading edge of the SYNC output precedes the leading edge of the main output. When in the DOUBLE PULSE position, the main output provides two successive output pulses having a separation determined by the DELAY (9) controls.

- (11) PULSE WIDTH Controls. The rotary switch selects one of five ranges and the vernier provides continuously variable control of each range. The instrument is set to the pulse width indicated on the front panel when the vernier is in the "MAX" position.

50 ns - 1 us  
1 us - 10 us  
10 us - 100 us  
100 us - 1 ms  
1 ms - 10 ms

- (12) POLARITY Switch. If the polarity switch is in the "+" position, the main output pulse will pulse upwards (i.e. to a more positive level). If it is in the "-" position, the output will pulse downwards to a more negative level. If the setting of the polarity switch is changed when the output amplitude is relatively high (eg. > 25 Volts in the 100 Volt range), the output pulse will vanish for several tens of seconds until the high voltage levels on the output stage decay to a safe level. At that time the output will again become active. Note that the decay-delay time may be reduced significantly by briefly setting the rear panel HV switch in the "OFF" position (and then returning it to the "ON" position).

- (13) AMPLITUDE RANGE Switch. The rotary switch selects one of five ranges and the vernier (14) provides continuously variable control of each range. The instrument is set to the amplitude indicated on the front panel when the vernier is in the "MAX" position.

0 to 1 Volt	( $Z_{OUT}$ = 50 Ohm)
0 to 3 Volts	( $Z_{OUT}$ = 50 Ohm)
0 to 10 Volts	( $Z_{OUT}$ = 50 Ohm)
0 to 30 Volts	( $Z_{OUT}$ = 50 Ohm)
0 to 100 Volts	( $Z_{OUT}$ = 2 Ohm)

- (14) AMPLITUDE FINE. The ten turn amplitude vernier provides continuously variable control of the peak amplitude of the main output from 0 Volts to the maximum set by the range switch (see (13)). When the unit is operating at a low duty cycle and an attempt is made to reduce the output amplitude, the amplitude will decay slowly with a time constant of several tens of seconds. If a rapid decay is required, briefly switch the rear panel HV switch to the "OFF" position (and then back to the "ON" position).

- (15) OUT. BNC connector provides output to load impedance of 50 Ohms or higher.

- (16) OVERLOAD. An automatic overload protective circuit controls the front panel overload light. If the unit is overloaded (by operating at an exceedingly high duty cycle or by operating into a very low impedance), the protective circuit will turn the output of the instrument OFF and turn the indicator light ON. The light will stay ON (i.e. output OFF) for about 5 seconds after which the instrument will attempt to turn ON (i.e. light OFF) for about 1 second. If the overload condition persists, the instrument will turn OFF again (i.e. light ON) for another 5 seconds. If the overload condition has been removed, the instrument will turn on and resume normal operation. Overload conditions may be removed by:

- 1) Reducing PRF (i.e. switch to a lower range)
- 2) Reducing pulse width (i.e. switch to a lower range)
- 3) Removing output low load impedance (if any)
- 4) Reducing the output amplitude (i.e. switch to a lower range)

Note that the output stage will safely withstand a short circuited load condition.

#### D) REAR PANEL CONTROLS

- (1) AC POWER INPUT. A three-pronged recessed male connector is provided on the back panel for AC power connection to the instrument. Also contained in this assembly is a 1.0A slow blow fuse and a removable card that can be removed and repositioned to switch between 120V AC in and 240V AC in.
- (2) 2.0A SB. This fuse protects the output stage if the output duty cycle rating is exceeded.
- (3) AMP. To voltage control the output amplitude, set the switch in the EXT position and apply 0 to +10 Volts between terminal A and ground ( $R_{IN} > 10K$ ). The front panel controls are still active in this mode.
- (4) PW. The pulse generator may be triggered externally in a  $PW_{OUT} = PW_{IN}$  mode by setting the switch in the EXT position and applying a TTL level pulse of the desired pulse width to the A connector.
- (5) HV SWITCH. This switch must be in the "ON" position to obtain an output pulse. Note when the unit is operating at a low duty cycle and an attempt is made to reduce the output amplitude, the amplitude will decay slowly with a time constant of several tens of seconds. If a rapid decay is required, briefly switch the rear panel HV switch to the "OFF" position (and then back to the "ON" position). Also note that if the output pulse vanishes due to a changing of the position of the polarity (see paragraph 12, Front Panel Controls), the pulse recovery time may be reduced significantly by briefly setting the HV switch in the "OFF" position (and then returning it to the "ON" position).
- (6) MONITOR OUT. This BNC connector provides an output voltage pulse  $V_M$  (to 50 Ohms) which is a coincident replica of the load current pulse  $I_{LOAD}$  from the front panel OUT BNC connector as follows:

$$I_{LOAD} = V_M \text{ (Amps, Volts)}$$

For example, if  $V_M$  is determined to be 1.5 Volts (using an oscilloscope), the load current is 1.5 Amperes. Note that the monitor output voltage waveform includes the overshoot spikes shown below. These spurious spikes do not appear on the actual load current waveform.

$V_M$  WAVEFORM

LOAD VOLTAGE  
TO 50 OHMS.

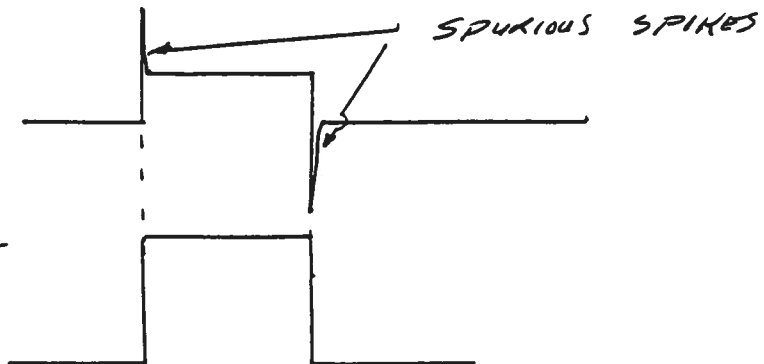

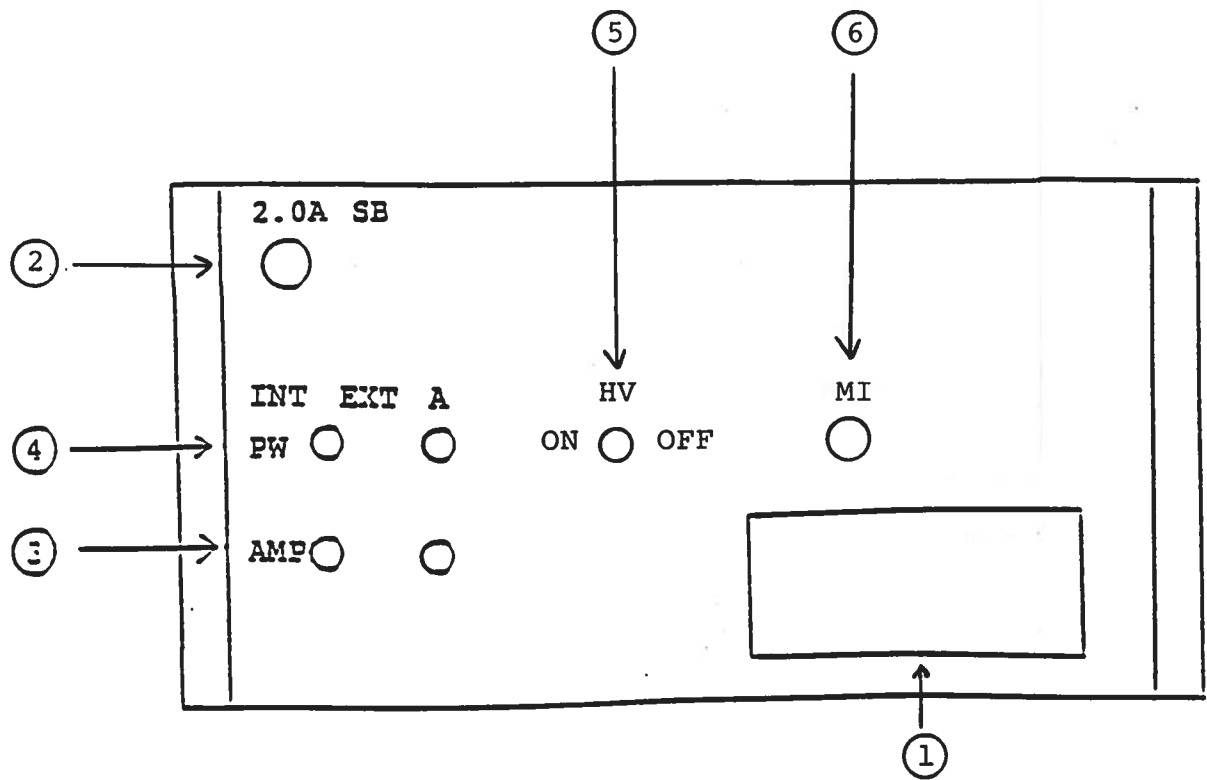

Fig. 2

REAR PANEL

E) TOP COVER REMOVAL AND RACK MOUNTING

- 1) The interior of the instrument may be accessed by removing the four Phillips screws on the top panel (see Fig. 1). With the four screws removed, the top cover may be slid back (and off).
- 2) The -R5 rack mount kit may be installed after first removing the one Phillips screw on the side panel adjacent to the front handle (see Fig. 1).

## F) THEORY OF OPERATION AND BASIC CIRCUITS

### BLOCK DIAGRAM DESCRIPTION

Refer to the Block Diagram (Fig. 3) for the following explanation.

The instrument is triggered by either an internal oscillator or an external source. When triggered externally, the trigger input is fed into a comparator circuit, which has a threshold voltage set by the LEVEL control (for further details, see the Threshold Module description). The output of the comparator is a TTL pulse.

The INT/EXT switch controls a gate that selects either the internal oscillator or the output of the threshold comparator. The output of this gate leads to an AND gate. The second input of the AND gate is the TTL complement of the GATE input, so that when the GATE input is TTL low (0V), the AND gate passes the trigger pulses and inhibits them when the GATE input is high.

At this point, the trigger signal is split into two parts. The lower channel drives a one-shot circuit, which delays the pulse, which is then buffered. The upper channel is buffered only. When in the DELAY or DOUBLE PULSE modes, the upper channel is connected, by a switch, to the front panel SYNC output. In the ADVANCE mode, the lower channel is connected instead.

The two channels then pass through the double-pulse circuitry. When in the ADVANCE or DELAY modes, both signals pass unaltered. In the DOUBLE PULSE mode, the upper channel is unaltered, but the two input channels are combined to create a new signal on the lower channel, yielding a series of double pulses.

When in the ADVANCE mode, the upper channel is switched in to drive the next circuit stage, the pulse width controller. In the DELAY or DOUBLE PULSE mode, the delayed lower channel drives the pulse width circuit. The output of the pulse width stage is a TTL pulse whose pulse width is equal to the pulse width of the instrument's front panel output.

At this stage, the user has the option of completely bypassing the instrument's timing circuitry by using the back panel PW switch and input connector. When the switch is in the INT position, the output of the pulse width stage is connected to the output stages of the instrument. In the EXT position, the output stages can be driven by TTL pulses on the back panel connector.

The output stages are all-solid-state, MOSFET totem pole circuits. There is a positive output and a negative output stage and the polarity switch selects one of the two outputs. The pulse width of the output pulse is equal to the pulse width of the input pulse and the amplitude of the output pulse is controlled by a combination of the DC voltage applied to the circuit and T-attenuators selected by the Amplitude Range switch.



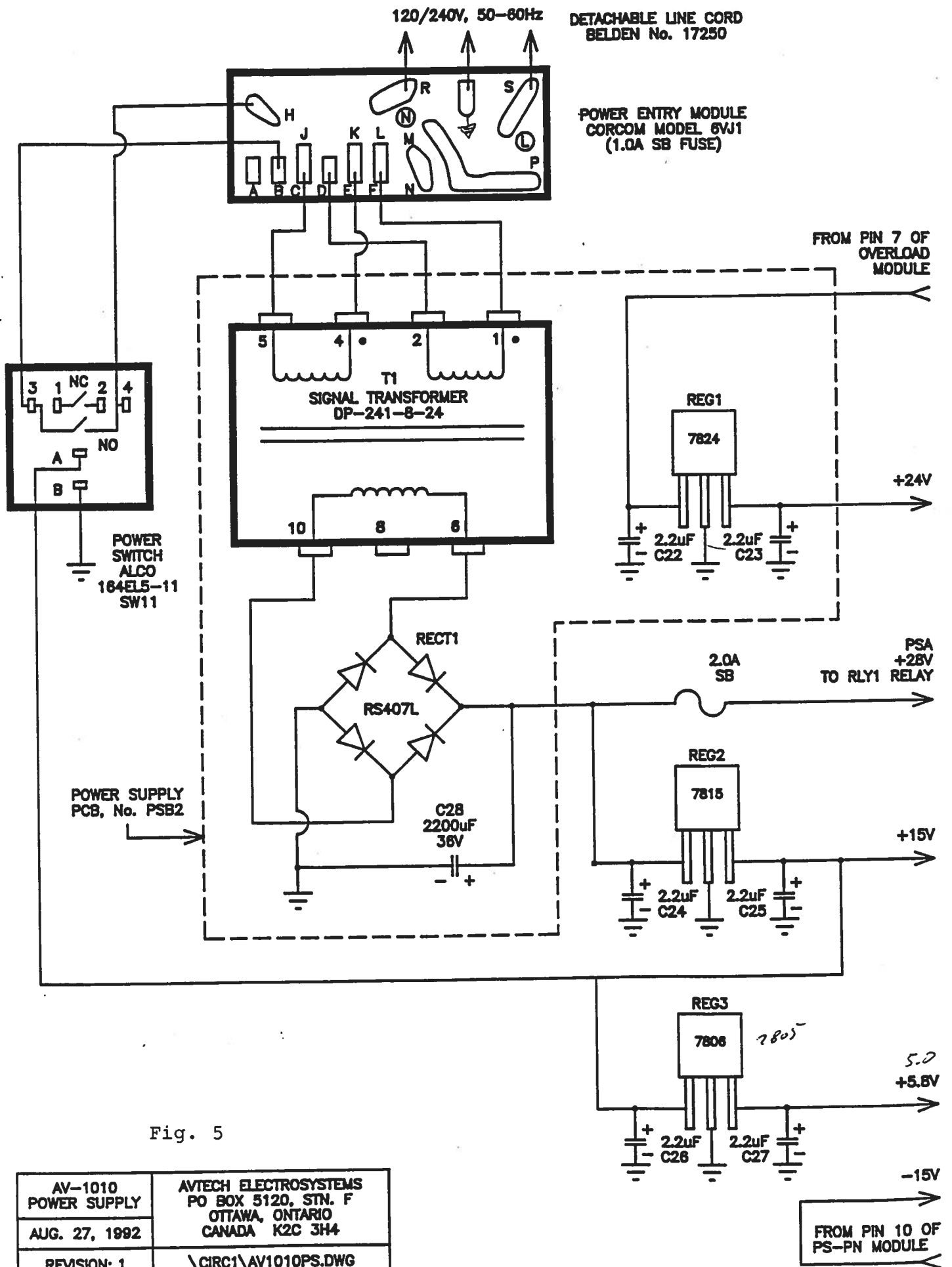
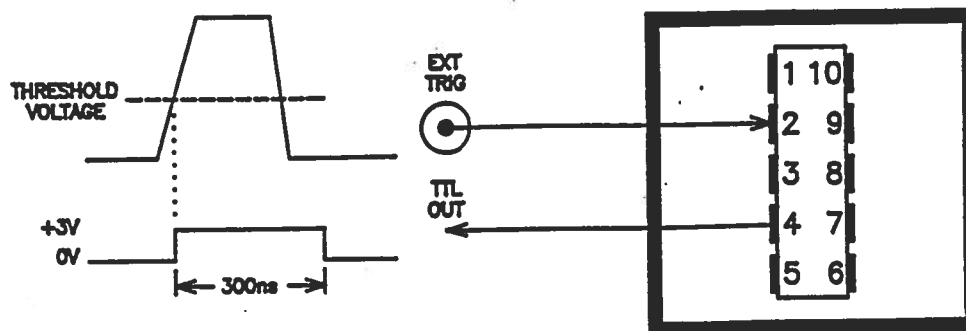

Fig. 5

AV-1010 POWER SUPPLY	AVTECH ELECTROSYSTEMS PO BOX 5120, STN. F OTTAWA, ONTARIO CANADA K2C 3H4
AUG. 27, 1992	
REVISION: 1	\CIRC1\AV1010PS.DWG

Fig. 6

THRESHOLD MODULE

The threshold module acts as a buffer for the EXT TRIG input. The module accepts trigger inputs of +0.5V to +40V in amplitude and generates a 300 ns TTL output pulse when the input passes a certain threshold voltage, set by the LEVEL knob on the front panel. When the threshold voltage is negative, the module will trigger when the input is more negative than the threshold. When the threshold voltage is positive, the module will trigger when the input is more positive than the threshold.

Pin connections

1. No connection
2. Input, connected to "EXT TRIG" BNC connector on the front panel
3. -15V input
4. TTL Out (to pin 15 of clock module)
5. Ground
6. Ground
7. +5V input
8. +15V input
9. Level. This pin is connected to the front panel "LEVEL" potentiometer. The voltage on this pin is proportional to the trigger threshold. The voltage ranges between -15V and +15V, which sets the threshold at +40V and -40V, respectively.
10. No connection

Fig. 7

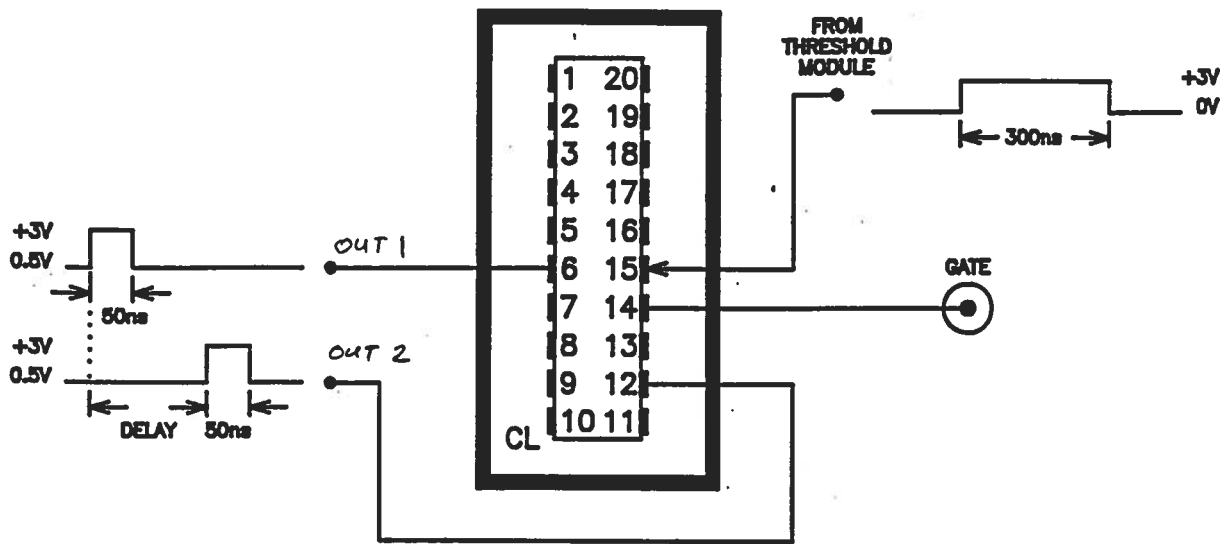
CLOCK MODULE

The clock module provides most of the AV-1010's timing functions. The module can be triggered by an internal or an external trigger. If SW3 is in the EXT position, pin 7 is grounded and the module will be triggered by TTL pulses entering on pin 15, which connects to pin 4 of the threshold module. Also, when in the EXT mode, the AV-1010 can be triggered by the SINGLE PULSE push button (SW10). Each press triggers one pulse. The normally open and normally closed terminals of the switch are connected to pins 17 and 4, respectively. The switch is debounced. When SW3 is in the INT position, pin 7 has +5.8V on it and the internal oscillator is enabled. The frequency of the oscillator is controlled by the capacitance across pins 2 and 3 and the voltage on pin 19. Different fixed capacitors, corresponding to different ranges, are switched in by the PRF RANGE switch (SW4) and the PRF FINE potentiometer varies the frequency continuously by varying the voltage on pin 19 between 0 and +5.8V. The frequency can be varied between 10 Hz and 1 MHz.

The trigger pulse, whether internal or external, is then split into two channels. The first channel is fed into a monostable multivibrator which produces a nearly coincident pulse with a fixed, 50 ns pulse width. This pulse is buffered and is available on pin 6.

The second channel is delayed by between 100 ns and 10 ms. The delay time is controlled by the capacitance between pins 8 and 13 and the resistance between pin 8 and the +5.8V power supply. Different fixed capacitors, corresponding to different delay ranges, are switched in by the DELAY RANGE switch, SW1. The resistance is varied by the DELAY potentiometer, PT3, and a series of minimum fixed resistances, switched in by SW1. This delayed pulse is then fed into a monostable multivibrator to give a fixed 50 ns pulse width. SW5 is in the DELAY or ADVANCE positions, the pulse is buffered and applied directly to pin 12. If SW5 is in the DOUBLE PULSE position, the two channels are added together to give a double pulse on pin 12, with the spacing between the leading edges of the pulses controlled by the delay controls.

When SW5 is in the DELAY or DOUBLE PULSE positions, pin 6 is connected to the SYNC OUT connector and pin 12 is connected to pin 4 of the pulse width module. In the DELAY mode, the main output of the AV-1010 lags after the SYNC output. In the DOUBLE PULSE mode, the first pulse is nearly coincident with the first output pulse in the doublet. In the ADVANCE mode, the connections for pins 6 and 12 are swapped and the main output pulse precedes the SYNC pulse. The module also contains a GATE input, pin 14, which connects to the GATE connector on the front panel. When a TTL high level (+2 to +5V) is applied, triggering will be inhibited in all modes. Normal triggering occurs when the GATE input is held low or when the GATE input is left open (unconnected).

#### Pin connections

1. Ground
- 2,3. The capacitance across the pins controls the frequency range of the internal oscillator
4. This is connected to the normally open terminal of SW10
5. +5.8V in
6. Output 1. This is the leading output. The 50 ns pulse is used as the SYNC OUT pulse in the DELAY and DOUBLE PULSE modes and as the trigger for the PW module in the ADVANCE mode.
7. INT/EXT. When this pin is grounded, by SW3, the clock module is triggered by pin 4 of the threshold module. When this pin is held at +5.8V, the module is triggered by its internal oscillator.
8. The delay timing resistance is placed across this pin and +5.8V by SW1 and PT3
- 8,13. The delay timing capacitance is placed across these pins by SW1
9. No connection

10. Ground
11. Ground
12. Output 2. This is the delayed output. The 50 ns pulse is used as the SYNC OUT pulse in the ADVANCE mode and as the trigger for the PW module in the DELAY and DOUBLE PULSE modes.
- 13,8. The delay timing capacitance is placed across these pins by SW1
14. Gate. Triggering is inhibited in all modes when a TTL high (+24V to +5V) is applied to this pin. Connected to front panel GATE connector.
15. EXT Trig. This input, from pin 4 of the threshold module, triggers the clock module when the INT/EXT switch (SW3) is in the EXT position.
16. This pin is an unbuffered replica of Output 2 (pin 12). Not used.
17. Single/Double. When this pin is grounded by SW5, a single pulse appears each cycle at Output 1. When this pin is connected to +5.8V, Output 1 provides a double pulse with separation of the leading edges of the pulses controlled by the DELAY controls.
18. This is connected to the normally closed terminal of SW10
19. The voltage on this pin varies the frequency of the internal oscillator. The voltage varies between 0 and +5.8V, with the highest and lowest frequencies varying by approximately a factor of 10.
20. Ground

Fig. 8

PULSE WIDTH MODULE

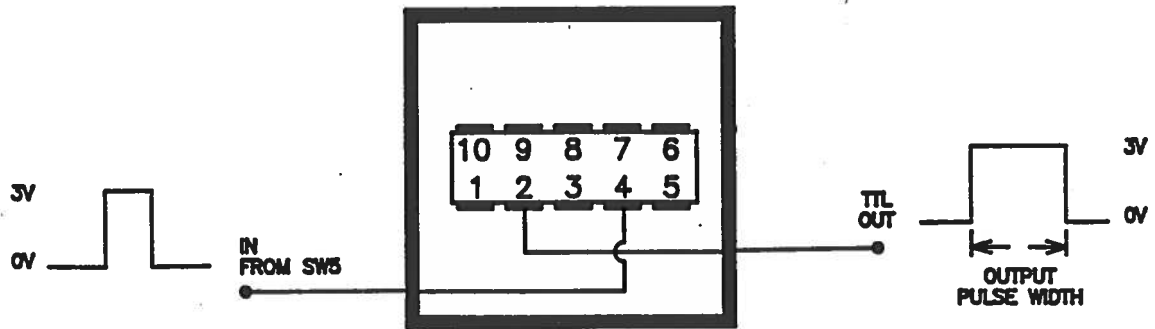

The pulse width module sets the pulse width of the main front panel output. The input is a TTL pulse from one of the two outputs on the clock module, selected by SW5. If the ADVANCE mode is selected, the SYNC pin of the clock module triggers the pulse module. If the DELAY or DOUBLE PULSE mode is selected, the OUT pin of the clock module triggers the pulse module.

The output pulse width is determined by the resistance across pins 8 and 9 and by the capacitance across pins 7 and 8. The capacitance is varied in steps by the fixed capacitors on the PULSE WIDTH RANGE switch (SW6). The resistance is controlled by the PULSE WIDTH FINE potentiometer, which is in series with a minimum fixed resistor also selected by SW6. The output is connected, through SW2, to both the PG-P and PG-N modules when SW2 is in the INT position.

Pin connections

1. No connection
2. TTL Out (to pin 1 of the PG-P and PG-N modules, through SW2)
3. TTL Out. This is the TTL complement of pin 2. Not used.
4. TTL In. Connected to either pin 6 (SYNC) or pin 12 (OUT) of the clock module, through SW5.
5. Ground
6. Ground
- 7,8. The timing capacitance is placed across these pins by SW6.
- 8,9. The timing resistance is placed across these pins by PT4 and SW6.
10. Ground

Fig. 9

PS-PN MODULE

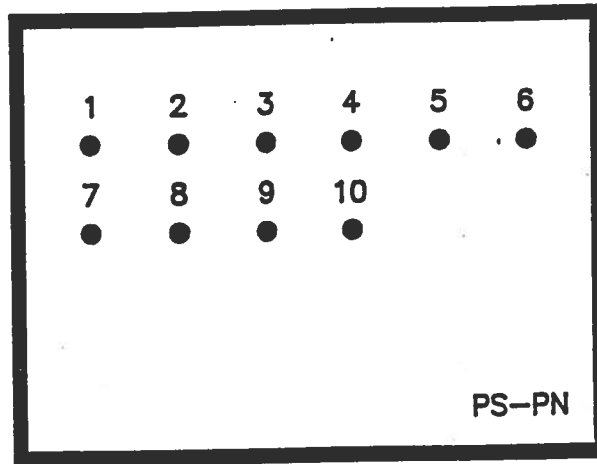

The PS-PN module supplies DC power to various other modules in the AV-1010. The PS-PN is supplied with +24VDC on pin 9. It, in turn, supplies -15V from pin 10 to the threshold module. *THIS module also PROVIDES THE HIGH VOLTAGE* power to the two pulse generator modules. Pin 7 supplies +10V to the AMP FINE potentiometer (PT5). This control and the resistors R30 to R38 on SW8 divide this voltage down to somewhere between 0 and 10V, which is then supplied to either pin 1 or 2, depending on the position of the polarity switch (SW9). If SW9 is in the POS position, the voltage is applied to pin 1 and +24V is supplied to pin 3. The PS-PN module amplifies the voltage on pin 3 by a factor of +11 using high voltage operational amplifiers and supplies this high voltage to pin 5 which then connects to pin 4 of the positive pulse generator module. Similarly, if SW9 is in the NEG position, the AMP FINE pot varies the voltage on pin 2 between 0 and +10V and +24VDC is supplied to pin 4, which activates the amplifier that supplies 0 to -110V to pin 6. Pin 6 connects to pin 4 of the negative pulse generator.

### Pin connections

1. Positive Amplitude Control. The voltage on this pin is amplified by a factor of +11 and the amplified voltage is supplied to pin 5.
2. Negative Amplitude Control. The voltage on this pin is amplified by a factor of -11 and the amplified voltage is supplied to pin 6.
3. +24V In. When +24V is applied to this pin, the positive amplifier (that amplifies the voltage on pin 1) is enabled.
4. +24V In. When +24V is applied to this pin, the negative amplifier (that amplifies the voltage on pin 2) is enabled.
5. 0 to +110V Out. This voltage is equal to the voltage on pin 1 multiplied by +11. This supplies power to pin 4 of the positive pulse generator module.
6. 0 to -110V Out. This voltage is equal to the voltage on pin 1 multiplied by -11. This supplies power to pin 4 of the negative pulse generator module.
7. +10V Out
8. No connection
9. +24V In.
10. -15V Out

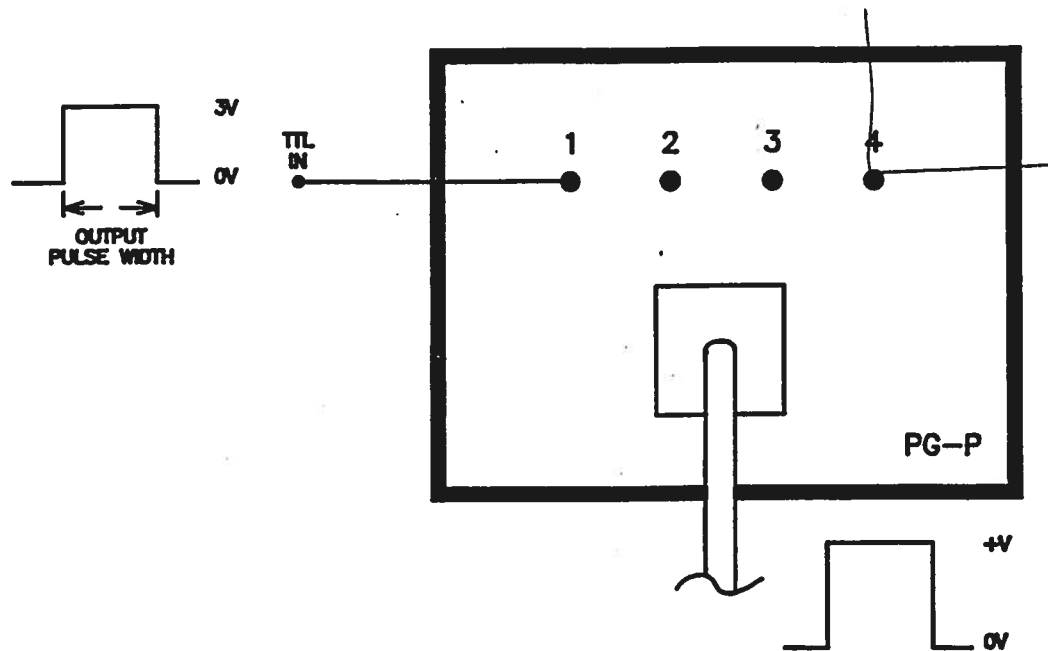

Fig. 10

POSITIVE PULSE GENERATOR MODULE

The positive pulse generator module <sup>is</sup> an all-solid-state totem pole MOSFET output stage. A TTL level input, applied to pin 1, triggers the module. The input source is either pin 2 of the pulse width module or a connector on the back panel of the instrument, selected by SW2. The output pulse width is equal to the input pulse width and the output amplitude is equal to the voltage on pin 4 (which can vary between 0 and +110V) minus a voltage drop due to the module's 2 Ohm output resistance. The voltage on pin 4 is controlled by the PS-PN module which, in turn, is controlled by the AMP RANGE SWITCH (SW8) and the AMP FINE potentiometer (PT5). Pin 4 is bypassed with large energy-storage capacitors to minimize droop.

The module's output is taken from the SMA connector and fed into SW8. When not in the 100V range, the output is connected to one of several T attenuators, depending on the voltage range.

When SW9 is in the POS position, the module is supplied with power by the +24VDC solder terminal on the rear of the module.

The MOSFET transistors (AVTECH Part No. SL5T) are field replaceable and are accessed by removing the 5 cm x 10 cm cover plate on the bottom of the instrument. The two SL5T transistors in each module are bonded to a copper heat sink using WAKEFIELD TYPE 155 thermally conductive epoxy. The copper heat sink is attached to the bottom surface of the -PG module by two 2-56 screws.

## Pin connections

1. TTL In. Connected to either pin 2 of the pulse width module or to a back panel connector via SW2.
  2. No connection
  3. No connection
  4. Amplitude Control Voltage. This sets the output amplitude of the module. Connected to pin 5 of PS-PN module.
- SMA. Output. Connected to SW8.  
Rear. +24VDC in

Fig. 11

NEGATIVE PULSE GENERATOR MODULE

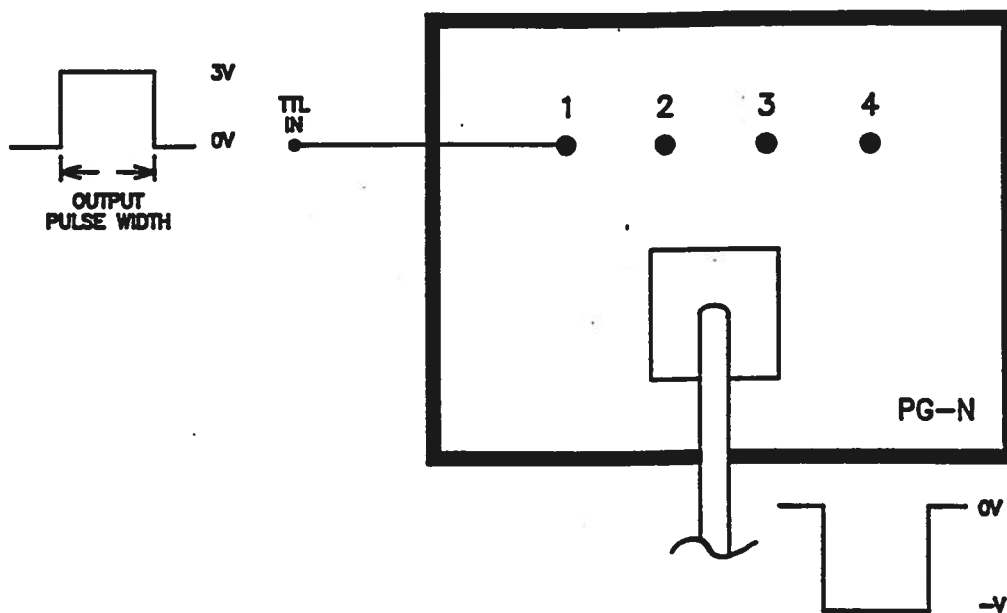

The negative pulse generator module <sup>1747</sup> is an all-solid-state totem pole MOSFET output stage. A TTL level input, applied to pin 1, triggers the module. The input source is either pin 2 of the pulse width module or a connector on the back panel of the instrument, selected by SW2. The output pulse width is equal to the input pulse width and the output amplitude is equal to the voltage on pin 4 (which can vary between 0 and -110V) minus a voltage drop due to the module's 2 Ohm output resistance. The voltage on pin 4 is controlled by the PS-PN module which, in turn, is controlled by the AMP RANGE SWITCH (SW8) and the AMP FINE potentiometer (PT5). Pin 4 is bypassed with large energy-storage capacitors to minimize droop.

The module's output is taken from the SMA connector and fed into SW8. When not in the 100V range, the output is connected to one of several T attenuators, depending on the voltage range.

When SW9 is in the NEG position, the module is supplied with power by the +24VDC solder terminal on the rear of the module.

The MOSFET transistors (AVTECH Part No. SL5T) are field replaceable and are accessed by removing the 5 cm x 10 cm cover plate on the bottom of the instrument. The two SL5T transistors in each module are bonded to a copper heat sink using WAKEFIELD TYPE 155 thermally conductive epoxy. The copper heat sink is attached to the bottom surface of the -PG module by two 2-56 screws.

### Pin connections

1. TTL In. Connected to either pin 2 of the pulse width module or to a back panel connector via SW2.
  2. No connection
  3. No connection
  4. Amplitude Control Voltage. This sets the output amplitude of the module. Connected to pin 6 of PS-PN module.
- SMA. Output. Connected to SW8.  
Rear. +24VDC in

AV-1010  
 WIRING DIAGRAM  
 AUG. 19, 1982  
 REVISION: 1

AVTECH ELECTROSYSTEMS  
 PO BOX 5122, STN. F  
 OTTAWA, ONTARIO  
 CANADA K2C 3H4

\\CIRC1\AV1010-1.DWG

FIG 4

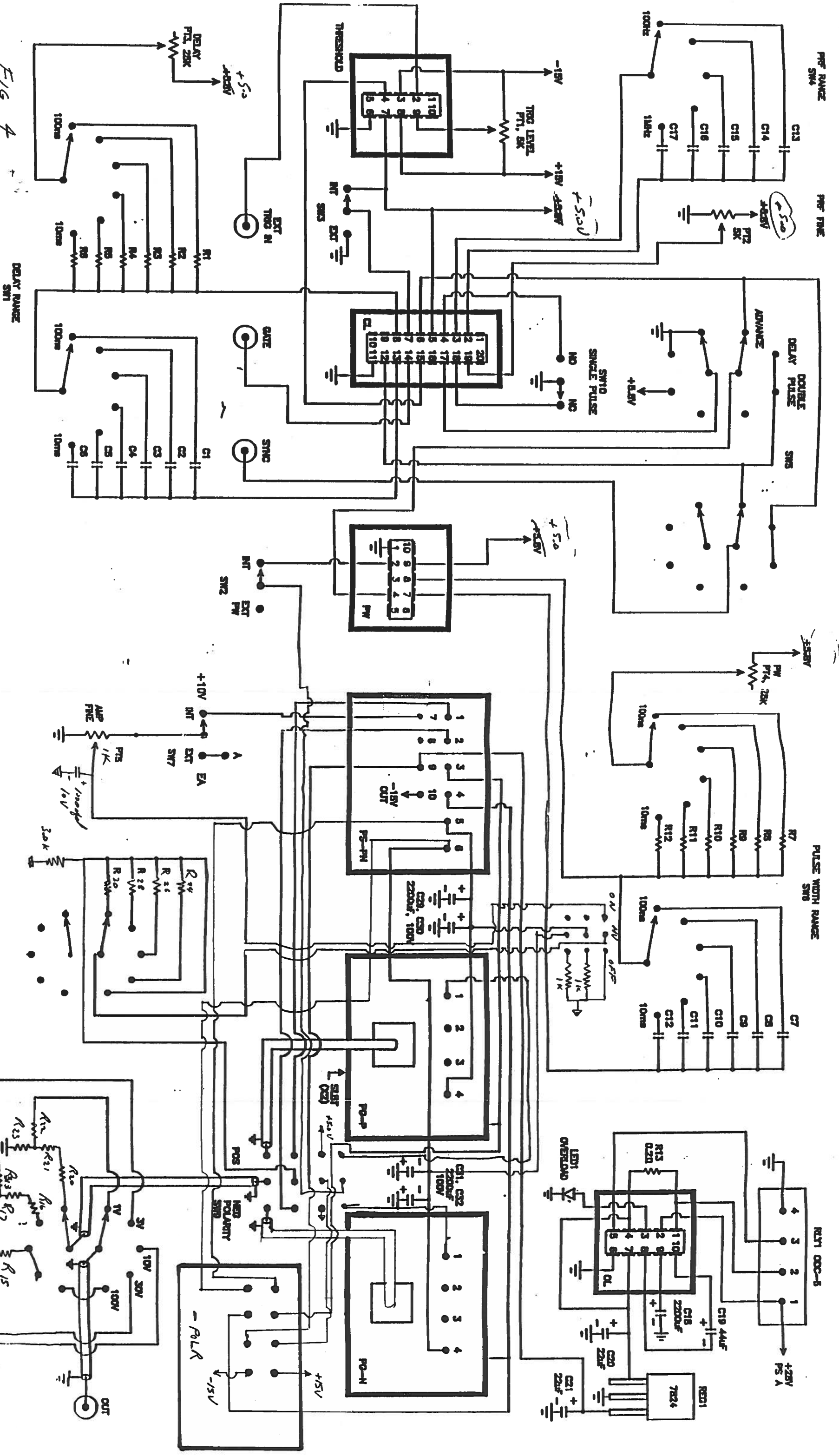

AMP RANGE  
 SW8

PWF RANGE  
 SW4

PWF RANGE  
 SW4

DOUBLE  
 DELAY PULSE  
 SW5

PULSE WIDTH RANGE  
 SW8

REL1 00C-5

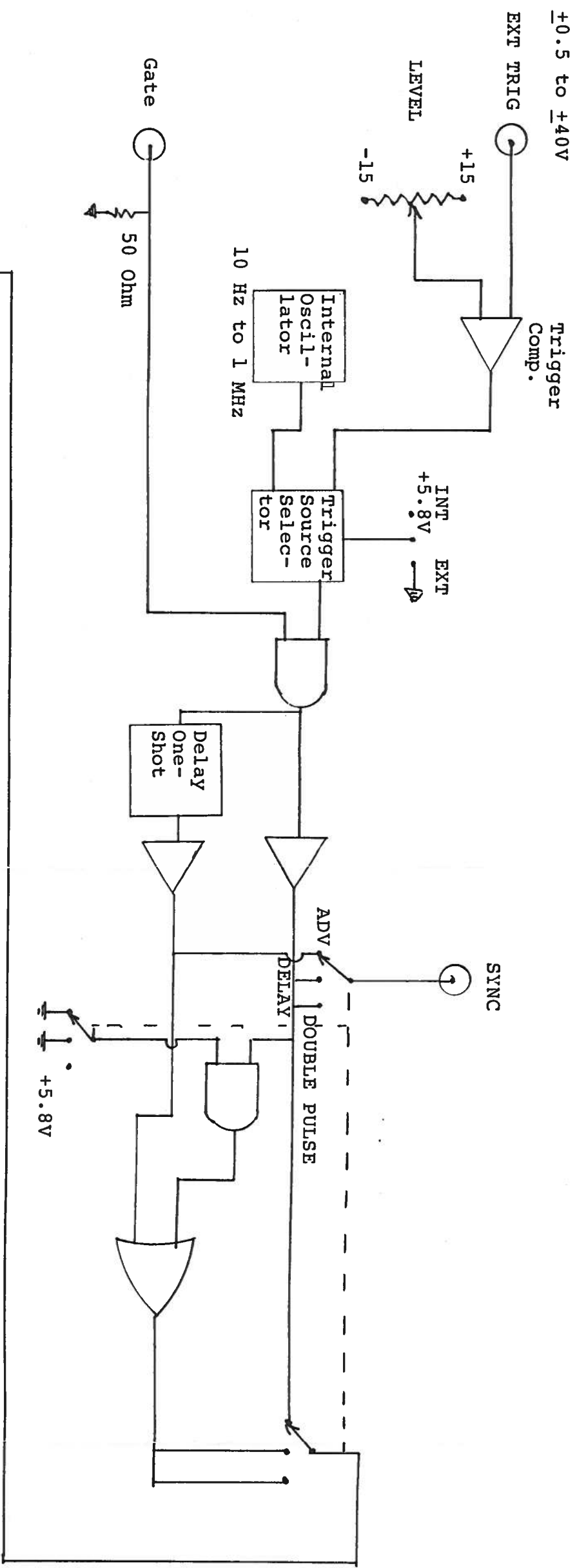
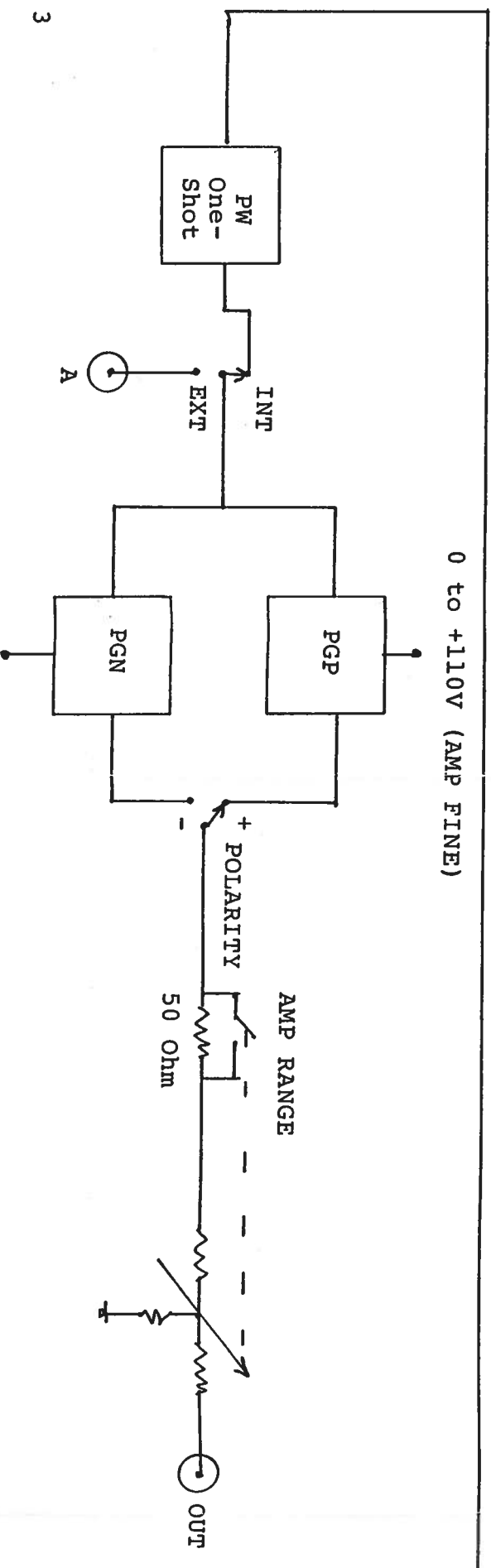

Fig. 3



BLOCK DIAGRAM	AVTECH ELECTROSYSTEMS PO BOX 5120, STN. F OTTAWA, ONTARIO CANADA K2C 3H4
AUG. 27, 1982	
REVISION: 1	AV1010PS.DWG

MODEL AV-1010-C BLOCK DIAGRAM

Nov. 20/95

edition B

-R5

Disk: AV-1010

Name: 1010CMIB.INS