



AVTECH ELECTROSYSTEMS LTD.

NANOSECOND WAVEFORM ELECTRONICS
SINCE 1975

□ P.O. BOX 265
OGDENSBURG, NY
U.S.A. 13669-0265
TEL: (315) 472-5270
FAX: (613) 226-2802

TEL: 1-800-265-6681
FAX: 1-800-561-1970

e-mail: info@avtechpulse.com
<http://www.avtechpulse.com>

□ P.O. BOX 5120 STN. F
OTTAWA, ONTARIO
CANADA K2C 3H4
TEL: (613) 226-5772
FAX: (613) 226-2802

INSTRUCTIONS

MODEL AV-1030-C PULSE GENERATOR

S.N.:

WARRANTY

Avtech Electrosystems Ltd. warrants products of its manufacture to be free from defects in material and workmanship under conditions of normal use. If, within one year after delivery to the original owner, and after prepaid return by the original owner, this Avtech product is found to be defective, Avtech shall at its option repair or replace said defective item. This warranty does not apply to units which have been disassembled, modified or subjected to conditions exceeding the applicable specifications or ratings. This warranty is the extent of the obligation assumed by Avtech with respect to this product and no other warranty or guarantee is either expressed or implied.

TECHNICAL SUPPORT

Phone: 613-226-5772 or 1-800-265-6681

Fax: 613-226-2802 or 1-800-561-1970

E-mail: info@avtechpulse.com

World Wide Web: <http://www.avtechpulse.com>

INTRODUCTION

The Avtech AV-1030-C is a versatile, general-purpose, low-cost, 200 ps rise time, 10MHz laboratory pulse generator, useful everywhere from undergraduate university classrooms to the most advanced research and development laboratories. This pulse generator features variable pulse repetition frequency (PRF), delay, pulse width and amplitude. Additionally, the generator can be triggered either internally or externally, as well as by the manual "Single Pulse" pushbutton. All trigger sources can be gated by a TTL-type pulse. PRF is continuously variable from 1kHz to 10MHz, delay to 1ms, pulse width to 1.0ms, and amplitude to $\pm 5V$ (to 50 Ohms). A synchronising trigger output is supplied when operating off of the internal trigger (+2V into 50 Ω , +4V into 1M Ω .)

SPECIFICATIONS

LOAD IMPEDANCE

This unit requires a 50 Ohm load impedance at all times.

PULSE REPETITION FREQUENCY

The PRF is continuously variable from 1kHz to 10MHz in 8 ranges, each range providing a ratio of approximately 3 between its highest and lowest frequency.

DELAY

The delay between the SYNC output or the external trigger is variable from 10ns to 1ms in five ranges. Delay is variable over 75% of the pulse period up to 1MHz, decreasing to 50% at 10MHz.

PULSE WIDTH (AND DUTY CYCLE)

Pulse width is measured at the 50% amplitude point, and is continuously variable from 10ns to 1.0ms. Duty cycle may range up to 10%.

RISE/FALL TIMES

The rise and fall times are measured from the 20% to 80% amplitude levels with the output terminated into 50Ω. The rise time is fixed at less than 200ps while the fall time is fixed at less than 300ps.

AMPLITUDE

The amplitude of the main output is continuously variable between zero and five volts to 50 Ohms, with the polarity controlled by the polarity switch. The amplitude can be varied in three ranges, from, 0 to 0.5V, and 0 to 5V.

SOURCE IMPEDANCE

The output resistance is 50Ohms. Note that this unit requires a 50 Ohm load impedance.

SYNC OUT

When triggering off of the internal clock, the SYNC OUT/TRIG IN connector is used as a SYNC output, allowing the user to synchronise other equipment to the instrument (e.g. oscilloscopes). This output provides approximately +2V into a 50Ω load, or +4V into a 1MΩ load. This pulse leads the other outputs by a duration set by the "DELAY" controls, and has a pulse width of approximately 10ns. A sync signal is not provided in the external mode.

EXTERNAL TRIGGER

When the "INT/EXT" switch is in the EXT position, the instrument triggers off of an external signal, which must be supplied by either a TTL type signal (i.e. 0 to +5V) on the "SYNC OUT/TRIG IN" connector or by pressing the "SINGLE PULSE" pushbutton. The external trigger must be at least 4ns wide. This input has a high input impedance (greater than 1kΩ).

SINGLE PULSE

Pressing the "SINGLE PULSE" pushbutton with the "INT/EXT" switch in the "EXT" position will generate a single output pulse on the Main and Logic outputs. Pressing the "SINGLE PULSE" pushbutton with the switch in the "INT" position has no effect.

GATE IN

The "GATE IN" input is a high impedance input that can be used to suppress the triggering of the instrument. Leaving this input unconnected, or applying a TTL high level (e.g. +2.8V to 5V) will permit normal triggering. Taking the input low (to ground, or less than +0.8V) will inhibit any sort of triggering.

JITTER

Repetition rate, delay, and pulse width jitter are less than $\pm 15\text{ps}$ or $\pm 0.01\%$, whichever is greater.

WAVEFORM ABERRATIONS

Overshoot, undershoot, ringing, and top slope aberration are less than $\pm 3\%$ at amplitudes of 300mV and higher with outputs terminated in 50Ω .

OUTPUT PROTECTION

Caution: this unit requires a 50 Ohm load impedance and may be damaged by operating into an open circuit or a short circuit. Also note that the unit may be damaged if operated at duty cycles higher than 50 %. The warranty does not apply to cases where damage has resulted from not following the load requirements

OPERATING TEMPERATURE

The instrument is rated for operation in ambient temperatures of $+15^{\circ}\text{C}$ to $+40^{\circ}\text{C}$.

POWER REQUIRED

A maximum of 30W is required. The instrument can operate on 120V AC or 240V AC, selectable on the back panel, at 50 to 60 Hz. (0.5 A SB line fuse).

PHYSICAL CHARACTERISTICS

The instrument is contained in a 4" x 16" x 12" anodised aluminium chassis with handles, with a mass of 10kg. Signal connectors are all BNC type.

ACCESSORIES

One instruction manual and one power cord are supplied with the instrument. An optional 19" rack mounting kit is available (Avtech Part No. -R4)

INSTALLATION

VISUAL CHECK

After unpacking the instrument, examine to ensure that it has not been damaged in shipment. Visually inspect all connectors, knobs, and the handles. Confirm that a power cord and instruction manual is with the instrument. (If the instrument has been damaged in shipment, file a claim immediately with the company that transported the instrument.)

PLUGGING IN THE INSTRUMENT

Examine the rear of the instrument. There will be a male power receptacle, a fuse holder, and the edge of the power selector card will be visible. Confirm that the power selector is in the correct orientation - it should be marked either 120 or 240, indicating whether it expects 120V AC or 240V AC. If it is not set for the proper voltage, remove the fuse, then grasp the card with a pair of pliers and remove it. Rotate horizontally through 180 degrees. Reinstall the card and the correct fuse. In the 120V setting, a 1/2A slow blow fuse is required. In the 240V setting, a 1/4A slow blow fuse is required.

OPERATIONAL CHECK

This check is to confirm that the instrument is fully functional. In all tests, use a 50 Ω cable and note that the "out" port requires a 50 Ohm load at all times. Set the controls to the following values:

INT/EXT Switch: INT position

REPETITION RATE RANGE Switch: 100 kHz

REPETITION RATE Vernier: MAX

DELAY RANGE Switch: 100ns

DELAY Vernier: MIN

PULSE WIDTH RANGE Switch: 100ns

PULSE WIDTH Vernier: MAX

POLARITY Switch: +

AMPLITUDE RANGE Switch: 5V

AMPLITUDE Vernier: MAX

Connect a cable from the SYNC OUT/TRIG IN connector to the TRIG input of an oscilloscope (preferably one rated for at least 20MHz.) A second cable from the main output should be connected to a 20 to 40 dB attenuator pad connected to the 50 Ohm input of a fast scope ($BW \geq 2 \text{ GHz}$). Caution the "out" port requires a 50 Ohm termination.

Set the oscilloscope to trigger externally. Then follow the instructions on the next page, and compare what is seen on the oscilloscope to what is described. Only approximate values are needed to confirm operation.

<u>STEP</u>	<u>CONTROL</u>	<u>OPERATION</u>	<u>RESULTS</u>
1	POWER	Push in (ON)	+5V pulses at the main output, with period 10 μ s, pulse width 100ns, <200ps rise and fall times.
2	REPETITION RATE VERNIER	Rotate to MIN, then to MAX	Period rises to about 30 μ s, then falls to about 10 μ s.
3	DELAY VERNIER	Rotate to MAX, then to MIN	Pulses shift to the right on the oscilloscope by 100ns, then back.
4	PULSE WIDTH VERNIER	Rotate to MIN, then to MAX	Pulses become very narrow (about 10ns wide), then return to 100ns pulse width.
5	POLARITY SWITCH	Switch to -, then to +	Pulses swing between 0 and -5V, then swing between 0 and +5V.
6	AMPLITUDE RANGE	Switch to 1.5V, then 0.5V, then back to 5V	Amplitude falls to +1.5V, then +0.5V, then rises back up to +5V.

OPERATING INSTRUCTIONS

POWER Switch

The POWER pushbutton switch applies AC prime power the primaries of the transformer, turning the instrument on. The pushbutton lamp (#382 type) is connected to the +15V DC supply.

INT/EXT Switch

In the "INT" position the instrument is internally triggered and the "SYNC OUT/TRIG IN" connector provides a SYNC output, which allows one to trigger other instruments, such as oscilloscopes. In the "EXT" position the instrument is triggered by a TTL level input pulse on the "SYNC OUT/TRIG IN" connector, or by pressing the "SINGLE PULSE" pushbutton.

SINGLE PULSE Pushbutton

The "SINGLE PULSE" pushbutton will trigger the instrument manually for one cycle of output, when the "INT/EXT" switch is in the "EXT" position. Otherwise, the pushbutton has no effect.

SYNC OUT/TRIG IN Connector

When in the "INT/EXT" switch is in the "INT" position, this connector supplies a SYNC output, that can be used to trigger other equipment, particularly oscilloscopes. This signal leads the main output by a duration set by the "DELAY" controls, and has an approximate amplitude of +2V in 50 Ω , or +4V into 1M Ω , with a pulse width of about 10ns. When the switch is in the "EXT" position, the external trigger is applied to this connector. This input presents a high impedance (greater than 1k Ω). Should an input impedance of 50 Ω be required, it must be added manually at the input.

GATE Input

The GATE input will suppress the triggering of the instrument if grounded, or taken to a TTL LOW level (i.e. 0 to 0.8V). If it is left open, or taken to a TTL HIGH level (i.e. +2.4V to 5.0V), normal triggering will occur. This connector has a high input impedance (greater than 1k Ω .)

REPETITION RATE Controls

The rotary switch marked "RANGE" selects the pulse repetition rate for the internally triggered mode.

The vernier (labelled "MIN - MAX" provides continuously variable control of each range. There are ten ranges and the instrument is set to the rate indicated on the front panel when the vernier is in the "MAX" position.

DELAY Controls

The rotary switch selects one of five ranges and the vernier provides continuously variable control of each range. The instrument is set to the delay indicated on the front panel when the vernier is in the "MAX" position.

PULSE WIDTH Controls

The rotary switch selects one of five ranges and the vernier provides continuously variable control of each range. The instrument is set to the pulse width indicated on the front panel when the vernier is in the "MAX" position.

POLARITY Switch

If the polarity switch is in the "+" position, the main output pulse will pulse upwards (i.e. to a more positive level.) If it is in the "-" position, the output will pulse downwards, to a more negative level.

AMPLITUDE RANGE Switch

When in the 0.5V range, the main output is between variable in amplitude from 0 to ± 0.5 V, peak to peak. Similarly, in the 1.5V and 5V ranges, the amplitude is variable from 0 to ± 1.5 V and ± 5 V respectively. All ranges have 50 Ω backmatching.

AMPLITUDE Controls

The amplitude vernier provide continuously variable control of the peak to peak amplitude of the main output, from zero Volts to the maximum set by the range switch.

AC POWER INPUT

A three-pronged recessed male connector is provided on the back panel for AC power connection to the instrument. Also contained in this assembly is a 1/2A slow-blow fuse, and a removable card, that can be removed and repositioned to switch between 120V AC in and 240V AC in.

TOP AND BOTTOM COVER REMOVAL

The interior of the instrument may be accessed by removing the four Phillips screws on the rear panel. With the four screws removed, the top cover may be slid back (and off). In addition, the bottom cover may also be slid back (and off).

THEORY OF OPERATION AND BASIC CIRCUITS

The pulse generator circuits of the AV-1030 family are based largely on low-jitter ECL integrated circuit and state-of-the-art buffers and operational amplifiers (op amps). This allows an unprecedented level of integration for pulse generators, and lessens the reliance on discrete components. Discrete components (i.e. transistors) have been used only in circuits where no satisfactory substitute was available. The extreme low output rise and fall times are achieved using a stop recovery diode output stage.

CIRCUIT DESCRIPTION

TRIGGER SOURCES

As shown in the simplified circuit diagram, all of the trigger sources are fed into a multiplexer. The internal trigger is generated by the 1658 ECL oscillator (IC2), whose output frequency is controlled by the capacitance across pins 11 and 14, and the voltage on pin 2. The REPETITION RATE RANGE switch changes the capacitor, while the vernier varies the voltage on pin 2 between 0V and -2V. The output of the 1658 oscillator is fed into the 10174 four-into-one multiplexer (IC3). When the INT/EXT switch is in the INT position, the multiplexer selects the 1658 as its output. When the INT/EXT switch is in the EXT position, the multiplexer will select either the input that is held at a logic "high", or the external trigger input. If the SINGLE PULSE pushbutton is not depressed, the external trigger will be selected as the multiplexers output. When the user presses the SINGLE PULSE pushbutton, the logic "high" input is selected, and the output goes high, creating a short pulse. The output of this multiplexer then feeds the next stage of circuitry.

SYNC OUT CIRCUIT

The output of the 10174 multiplexer (IC3) triggers a 10198 one-shot (i.e. a monostable multivibrator, IC6), on the rising edge of the input pulse. The one-shot then pulses high for 10ns. The narrow pulse is then translated from ECL to TTL logic levels by a 10H125 level translator (IC7), which feeds a double emitter-follower buffer. This buffer drives a 50Ω resistor in series with the SYNC OUT output. Thus, the SYNC OUT output will have TTL levels (0V to approx. 3.5V) when driving a high impedance load, and an amplitude of exactly half that when driving 50Ω loads. (The series 50Ω resistor provides short circuit protection.) The SYNC OUT output is available on the SYNC OUT/TRIG IN connector only when the INT/EXT switch is in the INT position.

DELAY CIRCUIT

The output of the multiplexer also feeds another 10198 one-shot (IC5). This one-shot, however, outputs a pulse of variable width when triggered by the rising edge of the multiplexer output.

The pulse width is controlled by the capacitor between pin 4 and ground, and the resistance between pin 6 and pin 8 (the -5V power supply). The DELAY RANGE switch switches in different capacitors onto pin 4, and the vernier is in fact a potentiometer between pins 6 and 8, plus a minimum resistance, which is switched in by the range switch. The output of the 10198 is an inverted ECL pulse, whose width is equal to the delay between the SYNC OUT pulse and the main output (plus various other propagation delays.) This output drives the next stage.

PULSE WIDTH CIRCUIT

The first part of the pulse width circuit is almost identical to the delay circuit. The rising edge of the delay circuit output triggers the 10198 (IC8) to generate a non-inverted ECL pulse of variable duration. The duration sets the instrument's output pulse width. The range and vernier controls operate as in the delay section. The output of the 10198 is then transmitted through an AND gate (IC9), and the output of this gate is ANDed with its input. This serves to shave several nanoseconds off of the pulse, by taking advantage of the first AND gate's propagation delay. The two outputs of the second AND gate (it has both inverting and non-inverting outputs) drive the following sections.

LOGIC OUTPUTS

The two ECL outputs of the pulse width section are buffered by two CLC110 fast integrated circuit buffers (IC11 and IC13), so as to be able to drive 50Ω loads. Also, the two PW section outputs are translated to TTL levels, and these TTL pulses are buffered to drive 50Ω by two CLC404 op amps (IC12 and IC14). This gives four signals: a TTL pulse, and its complement, and an ECL pulse and its complement. To feed the two LOGIC outputs on the front panel, an M-2-5V-C93401 double-pole double-throw relay (RLY1) is used to select between these four outputs. One relay switch is used to select between the non-inverted TTL and ECL signals. When the TTL/ECL switch is in the TTL position, the relay is activated, and selects the TTL signal as output for the LOGIC connector. When in the ECL position, the relay disengages, and selects the ECL signal. The other relay switch selects between the inverting outputs in a similar fashion, for transmission to the other LOGIC output.

OUTPUT STAGE

The output stage takes advantages of several high-speed buffers and op amps. The output from the rise and fall time section is buffered by a CLC110 buffer (IC16), to drive 50Ω. The output of the buffer is fed into an MT-2-5V-C94301 relay (RLY2), which either sends the signal through an inverting buffer (the CLC404 op amp, IC17), or bypasses the buffer. If the POLARITY switch is set to "+", the op amp is bypassed, giving an output which swings between 0 and -2V. If the POLARITY switch is in the "-" position, the relay switches revert to the other condition, sending the signal through the op amp to give an output that swings between 0V and +2V. This output is fed into a 50Ω potentiometer (R65), which serves as the AMPLITUDE vernier.

A second relay then varies the gain-setting resistor of the SL50 output op amp (IC18). In the 5V and 10V amplitude ranges, the relay is closed, giving a total resistance of about 270Ω (R66). In the 1V range, the relay is open, so there is a series resistance of about 1.5kΩ. (The second gain-setting resistor for the SL50 op amp, a 1.5kΩ resistor, is contained inside the op amp case.) The SL50 op amp is set up in an inverting op amp configuration. The -TRF output module imparts the short rise and fall time properties to the output waveform.

POWER SUPPLIES

A dual secondary transformer (DMT-8-12) and seven linear regulator IC's are used to generate the following voltages:

-2	Volts	(150	mA)
-5.2	Volts	(600	mA)
+15	Volts	(200	mA)
-15	Volts	(100	mA)
+5	Volts	(350	mA)
+24	Volts	(20	mA)
-24	Volts	(20	mA)

The voltage test points are provided on the power supply printed circuit.

TEST POINT WAVEFORMS

Twelve key TP points (test points) are indicated on the circuit diagrams along with sample waveforms. In the event of an instrument failure or malfunction, the TP waveforms may be used to isolate and identify the offending circuit (or component). The twelve TP points are indicated in white lettering on the pulse generator printed circuit board.

f. i. s.

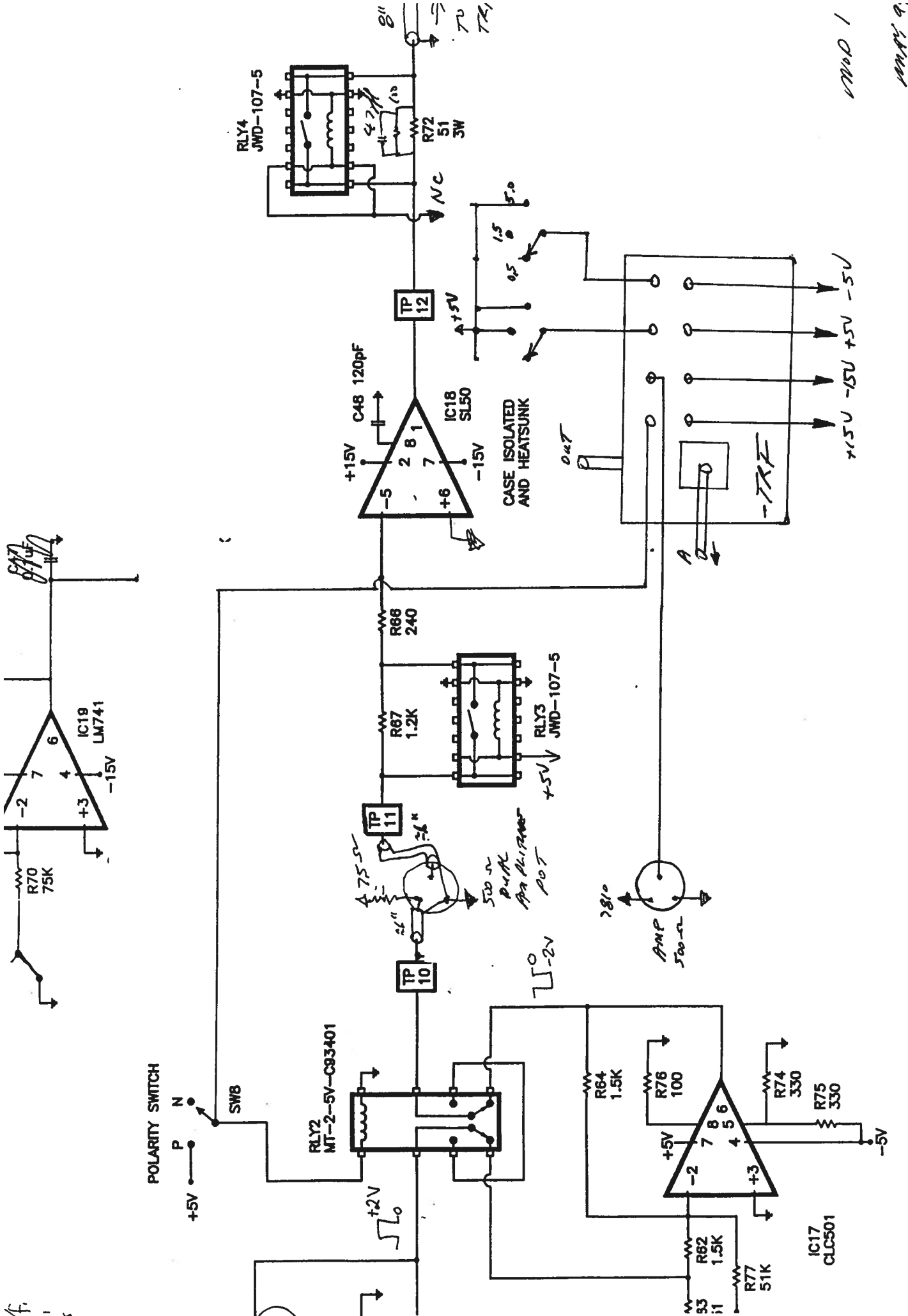

Mod 1
 MAP 9

AV-1030-C OUTPUT STAGE	AVTECH ELECTROSYSTEM PO BOX 265 OGDENSBURG, NY 13669 USA
AUG. 25, 1982	

PARTS LIST

INTEGRATED CIRCUITS

<u>PART NO.</u>	<u>SOURCE</u>	<u>DESCRIPTION</u>	<u>DEVICE</u>
IC1	VARIOUS	NAND GATE	74F00
IC2	MOTOROLA	OSCILLATOR	MC1658P
IC3	MOTOROLA	MULTIPLEXER	MC10174P
IC4	MOTOROLA	TTL-ECL TRANSLATOR	MC10H124P
IC5	MOTOROLA	ONE-SHOT	MC10198P
IC6	MOTOROLA	ONE-SHOT	MC10198P
IC7	MOTOROLA	ECL-TTL TRANSLATOR	MC10H125P
IC8	MOTOROLA	ONE-SHOT	MC10198P
IC9	MOTOROLA	AND GATE	MC10104P
IC10	MOTOROLA	ECL-TTL TRANSLATOR	MC10H125P
IC11	COMLINEAR	BUFFER	CLC110AJP
IC12	COMLINEAR	OP AMP	CLC404AJP
IC13	COMLINEAR	BUFFER	CLC110AJP
IC14	COMLINEAR	OP AMP	CLC404AJP
IC15	MOTOROLA	ECL-TTL TRANSLATOR	MC10H125P
IC16	COMLINEAR	BUFFER	CLC110AJP
IC17	COMLINEAR	OP AMP	CLC404AJP
IC18	AVTECH	OP AMP	SL50
IC19	VARIOUS	OP AMP	741

RELAYS

<u>PART NO.</u>	<u>SOURCE</u>	<u>DESCRIPTION</u>	<u>DEVICE</u>
RLY1	ITT	DPDT	MT-2-5V-C93401
RLY2	ITT	DPDT	MT-2-5V-C93401
RLY3	POTTER AND BRUMFIELD	SPST	JWD-107-5
RLY4	POTTER AND BRUMFIELD	SPST	JWD-107-5

DIODES

<u>PART NO.</u>	<u>SOURCE</u>	<u>DESCRIPTION</u>	<u>DEVICE</u>
D1			1N4150
D2			1N4150
D3			1N4150
D4			1N4150
D5			1N4150
D6			1N4150
D7			1N4150
D8			1N4150
D9			1N4150
D10			1N4150
D11	HEWLETT- PACKARD		5082-1001
D12			1N4150
D13			1N4150
D14	HEWLETT- PACKARD		5082-1001
D15			1N4150
D16			1N4150
D17			1N5819

CAPACITORS

<u>PART NO.</u>	<u>SOURCE</u>	<u>DESCRIPTION</u>	<u>DEVICE</u>
C1		820pF	
C2		10000pF	
C3		0.47uF	
C4		0.15uF	
C5		0.047uF	
C6		1000pF	
C7		5000pF	
C8		2400pF	
C9		2000pF	
C10		1000pF	
C11		300pF	
C12		470pF	
C13		120pF	
C14		33pF	
C15		8.2pF	
C16		100pF	

CAPACITORS (CONT'D.)

<u>PART NO.</u>	<u>SOURCE</u>	<u>DESCRIPTION</u>	<u>DEVICE</u>
C17		1000pF	
C18		300pF	
C19		4700pF	
C20		6800pF	
C21		0.1uF	
C22		0.022uF	
C23		100pF	
C24		1000pF	
C25		300pF	
C26		4700pF	
C27		6800pF	
C28		0.1uF	
C29		0.022uF	
C30		82pF	
C31		15pF	
C32		0.022uF	
C33		47uF	
C34		0.022uF	
C35		47uF	
C36		820pF	
C37		0.022uF	
C38		6.8uF	
C39		6.8uF	
C40		0.022uF	
C41		820pF	
C42		220pF	
C43		2500pF	
C44		0.033uF	
C45		0.33uF	
C46		2.2uF	
C47		2.2uF	
C48		120pF	

RESISTORS AND POTENTIOMETERS

<u>PART NO.</u>	<u>SOURCE</u>	<u>DESCRIPTION</u>	<u>DEVICE</u>
R1		4.7k Ω , 1/4W	
R2		4.7k Ω , 1/4W	
R3		4.7k Ω , 1/4W	
R4		4.7k Ω , 1/4W	
R5		25k Ω POTENTIOMETER	
R6		51 Ω , 1/4W	
R7		51 Ω , 1/4W	
R8		51 Ω , 1/4W	
R9		51 Ω , 1/2W	
R10		51 Ω , 1/4W	
R11		51 Ω , 1/4W	
R12		51 Ω , 1/4W	
R13		1k Ω , 1/4W	
R14		200 Ω , 1/4W	
R15	BOURNS	10K Ω POTENTIOMETER	
R16		51 Ω , 1/4W	
R17		200 Ω , 1/4W	
R18	BOURNS	10K Ω POTENTIOMETER	
R19		51 Ω , 1/4W	
R20		51 Ω , 1/4W	
R21		100 Ω , 1/4W	
R22		470 Ω , 1/4W	
R23		51 Ω , 1/4W	
R24		390 Ω , 1/4W	
R25		100 Ω , 1/4W	
R26		390 Ω , 1/4W	
R27		100 Ω , 1/4W	
R28		100 Ω , 1/4W	
R29		470 Ω , 1/4W	
R30		51 Ω , 1/4W	
R31		51 Ω , 1/4W	
R32		51 Ω , 1/4W	
R33		1.2k Ω , 1/4W	
R34		51 Ω , 1/2W	
R35		560 Ω , 1/4W	
R36		5.6k Ω , 1/4W	
R37		22 Ω , 1/4W	
R38		91 Ω , 1/4W	
R39		68 Ω , 1/4W	
R40		39k Ω , 1/4W	

RESISTORS AND POTENTIOMETERS (CONT'D.)

<u>PART NO.</u>	<u>SOURCE</u>	<u>DESCRIPTION</u>	<u>DEVICE</u>
R41		33Ω, 1/2W	
R42		10Ω, 1/4W	
R43		33Ω, 1/4W	
R44		25kΩ POTENTIOMETER	
R45		1.2kΩ, 1/4W	
R46		1.2KΩ, 1/4W	
R47		25kΩ POTENTIOMETER	
R48		10KΩ, 1/4W	
R49		56kΩ, 1/4W	
R50		10kΩ, 1/4W	
R51		27kΩ, 1/4W	
R52		2.7kΩ, 1/4W	
R53		2.2kΩ, 1/4W	
R54		25KΩ POTENTIOMETER	
R55		2.7kΩ, 1/4W	
R56		4.7kΩ, 1/4W	
R57		10kΩ, 1/4W	
R58		15kΩ, 1/4W	
R59		2.7Ω, 1/4W	
R60		1.2kΩ, 1/4W	
R61		25kΩ POTENTIOMETER	
R62		470Ω, 1/4W	
R63		51Ω, 1/4W	
R64		470Ω, 14W	
R65	BOURNS	50Ω POTENTIOMETER	
R66		270Ω, 1/4W	
R67		1.2kΩ, 1/4W	
R68		1.5kΩ, 1/4W	
R69		51kΩ, 1/4W	
R70		75kΩ, 1/4W	
R71		5kΩ POTENTIOMETER	
R72	IRC	51Ω, 3W	

- NOTE: UNLESS OTHERWISE SPECIFIED:
 1. ALL RESISTANCES ARE IN OHMS
 2. ALL RESISTORS ARE 1/4W
 3. ALL DIODES ARE 1N4150
 4. ALL POWER SUPPLIES ARE DECOUPLED TO GROUND WITH 0.1uF AND 22uF CAPACITORS (NOT SHOWN)
 5. *TP* MARKERS INDICATE TEST POINTS

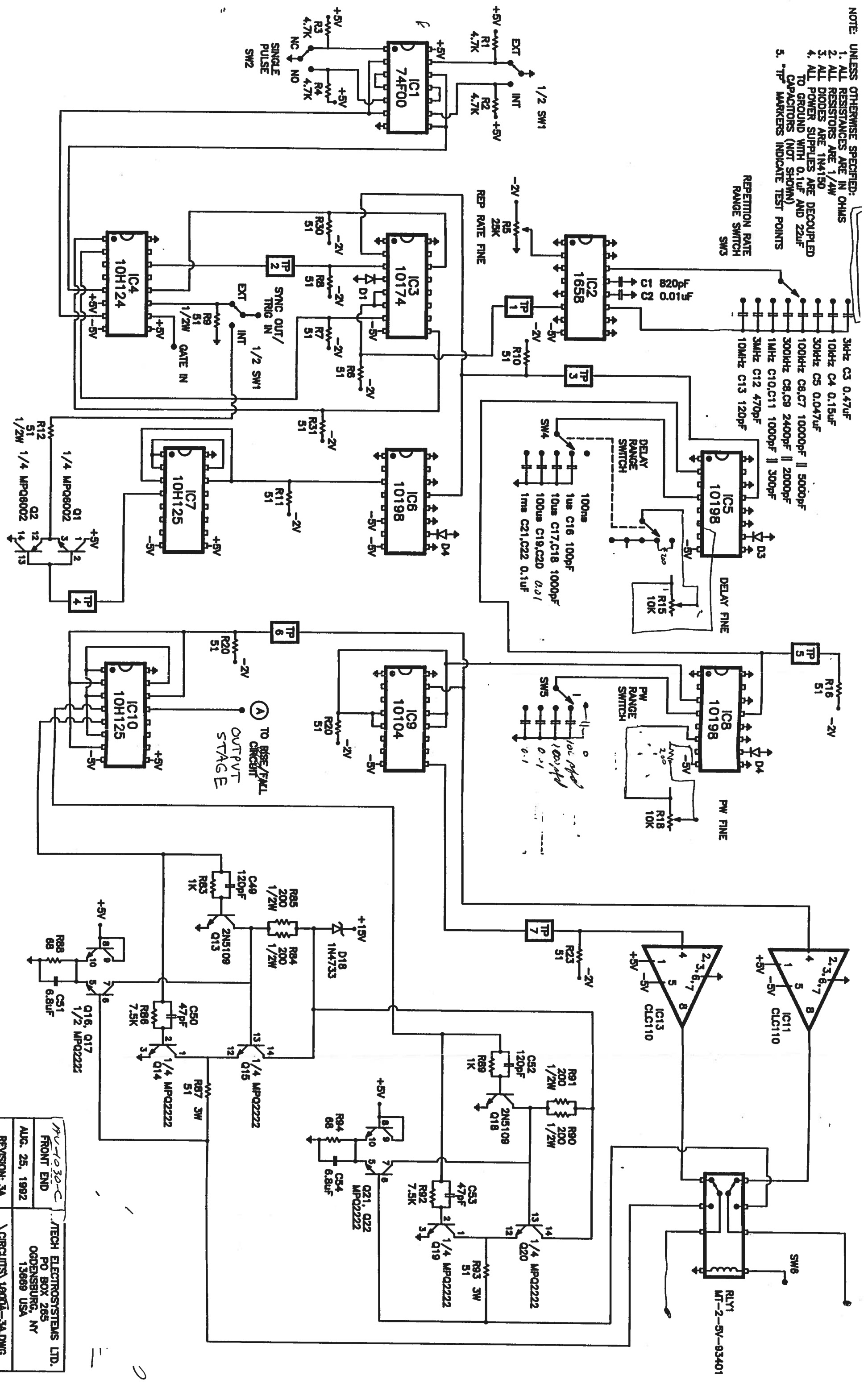

PC-1030-C
 FRONT END
 AUG. 25, 1992
 REVISION: 3A
 TECH ELECTROSYSTEMS LTD.
 PO BOX 265
 OGDENSBURG, NY
 13669 USA
 \CIRCUITS\1900A-3A.DWG

Created May 7/99
Step