



AVTECH ELECTROSYSTEMS LTD.

NANOSECOND WAVEFORM ELECTRONICS
SINCE 1975

P.O. BOX 265
OGDENSBURG, NY
U.S.A. 13669-0265
TEL: (315) 472-5270
FAX: (613) 226-2802

TEL: 1-800-265-6681
FAX: 1-800-561-1970

e-mail: info@avtechpulse.com
<http://www.avtechpulse.com>

P.O. BOX 5120 STN. F
OTTAWA, ONTARIO
CANADA K2C 3H4
TEL: (613) 226-5772
FAX: (613) 226-2802

INSTRUCTIONS

MODEL AV-156A-C PULSED CONSTANT CURRENT GENERATOR

S.N.:

WARRANTY

Avtech Electrosystems Ltd. warrants products of its manufacture to be free from defects in material and workmanship under conditions of normal use. If, within one year after delivery to the original owner, and after prepaid return by the original owner, this Avtech product is found to be defective, Avtech shall at its option repair or replace said defective item. This warranty does not apply to units which have been disassembled, modified or subjected to conditions exceeding the applicable specifications or ratings. This warranty is the extent of the obligation assumed by Avtech with respect to this product and no other warranty or guarantee is either expressed or implied.

TECHNICAL SUPPORT

Phone: 613-226-5772 or 1-800-265-6681

Fax: 613-226-2802 or 1-800-561-1970

E-mail: info@avtechpulse.com

World Wide Web: <http://www.avtechpulse.com>

TABLE OF CONTENTS

| | |
|---|----|
| WARRANTY..... | 2 |
| TABLE OF CONTENTS | 3 |
| FIG. 1: AV-156A-C PULSE GENERATOR TEST ARRANGEMENT..... | 4 |
| GENERAL OPERATING INSTRUCTIONS | 5 |
| FIG. 2: FRONT PANEL CONTROL..... | 8 |
| FRONT PANEL CONTROLS | 9 |
| FIG. 3: BACK PANEL CONTROLS..... | 12 |
| BACK PANEL CONTROLS..... | 13 |
| TOP COVER REMOVAL AND RACK MOUNTING..... | 14 |
| SYSTEM DESCRIPTION AND REPAIR PROCEDURE | 15 |
| START-UP CHECK LIST | 16 |
| PERFORMANCE CHECK SHEET | 17 |

**FIG. 1: AV-156A-C PULSE GENERATOR TEST ARRANGEMENT
(RESISTIVE LOAD)**

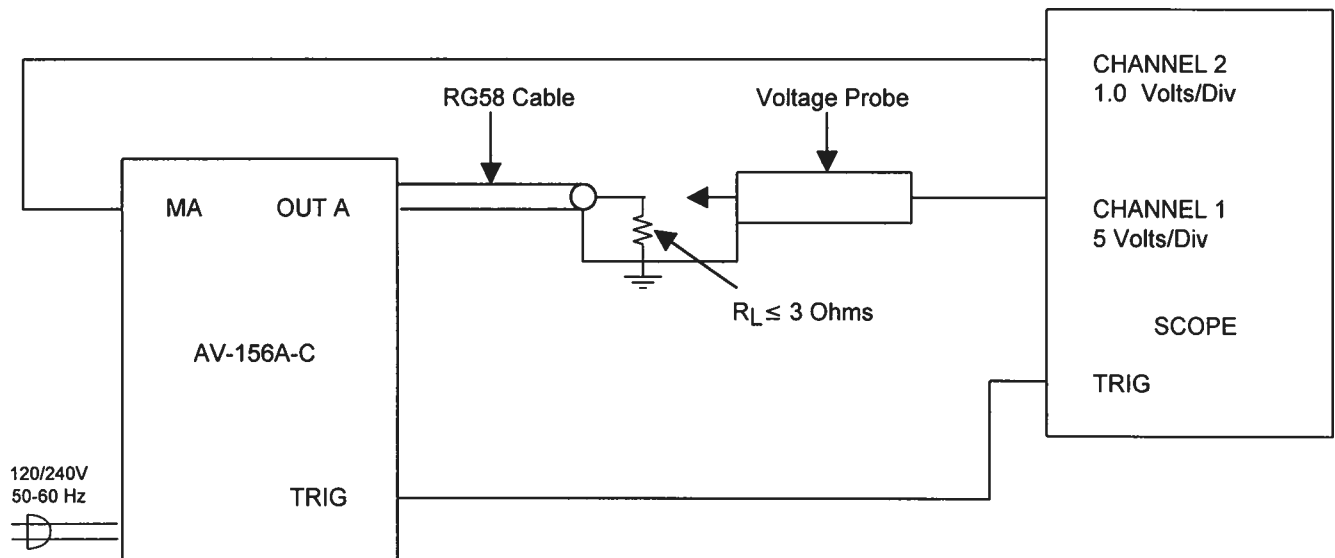

GENERAL OPERATING INSTRUCTIONS

- 1) The bandwidth capability of components and instruments used to display the pulse generator output signal (probes, cables, connectors, etc.) should exceed 10 MHz.
- 2) A low-inductance resistor should be used as the load. Note that an inductance of 1 μ h will yield an inductance spike of about 1.5 Volts. Also note that the load resistance must not exceed 3 Ohms (for a maximum output current of 5 Amps) because the compliance voltage rating of the unit is 15 Volts. Note that to obtain an output, the STANDBY-OPERATE switches must be in the OPERATE position.
- 3) The output pulse amplitude is controlled by means of the front panel ten turn AMP control and the two position range switch as follows:

| | |
|---------|-------------|
| Range 1 | 0 to 500 mA |
| Range 2 | 0 to 5 Amps |
- Note that the load voltage range (i.e. compliance voltage) of the unit is 15 Volts so the load resistance must be sufficiently low (≤ 3 Ohms) so that the load voltage does not exceed 15 Volts.
- 4) A DC offset of 0 to 500 mA may be added to the output pulse using the one-turn DC bias control.
- 5) To control the unit via the internal clock, set the INT-EXT switch in the INT position. The PRF is then variable from 0.1 Hz to 10 kHz.

- 6) The output pulse width is controlled by means of the front panel one turn PW control and by the PW RANGE control. Note that the MODE switch must be in the INT position. The minimum and maximum PW for each range and the corresponding maximum PRF are as follows. Note that the unit may fail if operated at duty cycles exceeding 20%.

| | PW MIN | PW MAX |
|---------|-------------------------|-------------------------|
| Range 1 | 10 us PRF max 10 kHz | 100 us PRF max 2 kHz |
| Range 2 | 100 us PRF max 10 Hz | 1 ms PRF max 200 Hz |
| Range 3 | 1 ms PRF max 200 Hz | 10 ms PRF max 20 Hz |

- 7) The DELAY control controls the relative delay between the reference output pulse provided at the TRIG output and the OUT port. This delay is variable over the range of 10 us to 10 ms as follows:

| | MIN | MAX |
|---------|--------|--------|
| Range 1 | 10 us | 100 ns |
| Range 2 | 100 us | 1 ms |
| Range 3 | 1 ms | 10 ms |

- 8) An external clock may be used to control the output PRF of the AV-156A unit by setting the MODE switch in the EXT position and applying a 50 ns (or wider) TTL level pulse to the TRIG BNC connector input. With the MODE switch in the EXT A position, the output pulse width will be controlled by the front panel PW controls. If the switch is in the MODE B position, the output pulse width equals the input trigger pulse width.
- 9) For single pulse manual operation, set the MODE switch in the MAN position and push the SINGLE PULSE button.
- 10) To obtain an output, the STANDBY-OPERATE switch must be in the OPERATE position. In the STANDBY position, a short circuit is placed across the output terminals and the output amplitude control signal is set to zero. This control may be used as a safety feature or as a means of deactivating the output.

- 11) **OVERLOAD.** An automatic overload protective circuit controls the front panel overload light. If the unit is overloaded (by operating at an exceedingly high duty cycle) the protective circuit will turn the output of the instrument OFF and turn the indicator light ON. The light will stay ON (i.e. output OFF) for about 5 seconds after which the instrument will attempt to turn ON (i.e. light OFF) for about 1 second. If the overload condition persists, the instrument will turn OFF again (i.e. light ON) for another 5 seconds. If the overload condition has been removed, the instrument will turn on and resume normal operation. Overload conditions may be removed by:

- 1) Reducing PRF (i.e. switch to a lower range)
- 2) Reducing pulse width (i.e. switch to a lower range)
- 3) Reducing the output amplitude

The overload light may illuminate when the prime power is first applied. The light will extinguish after a few seconds and the unit will then operate normally.

Note that the output stage will safely withstand a short-circuited load condition.

- 12) The unit is cooled by means of a self-contained cooling fan located on the bottom side of the instrument. The intake screen on the cooling fan should be cleared annually (using a strong vacuum cleaner).
- 13) The unit can be converted from 120 to 240V 50-60 Hz operation by adjusting the voltage selector card in the rear panel fused voltage selector-cable connector assembly.
- 14) For additional assistance:

Tel: (613) 226-5772
Fax: (613) 226-2802
Email: info@avtechpulse.com

FIG. 2: FRONT PANEL CONTROL

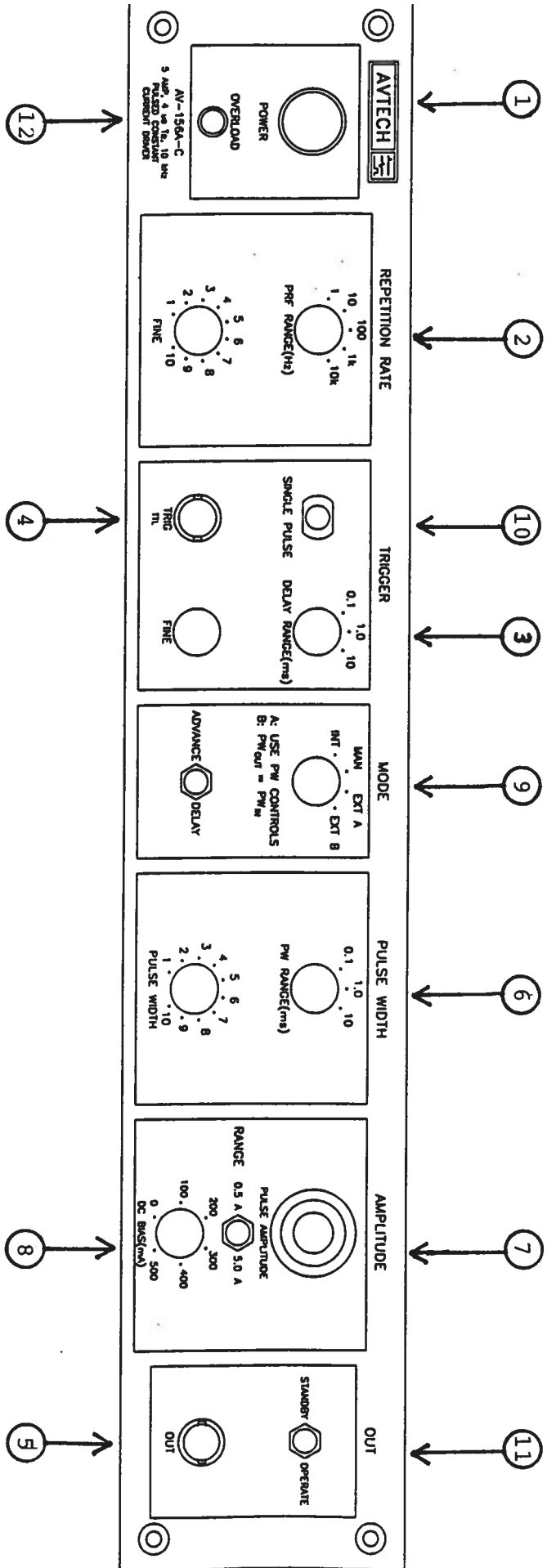

FRONT PANEL CONTROLS

- 1) ON-OFF Switch. Applies basic prime power to all stages.
- 2) PRF Control. Varies PRF from 1 Hz to 100 Hz as follows:

| | | |
|---------|--------|--------|
| Range 1 | 0 Hz | 1 Hz |
| Range 2 | 1 Hz | 10 Hz |
| Range 3 | 10 Hz | 100 Hz |
| Range 4 | 100 Hz | 1 kHz |
| Range 5 | 1 kHz | 10 kHz |

- 3) DELAY Control. Controls the relative delay between the reference output pulse provided at the TRIG output (4) and the main output (5). This delay is variable over the range of 10 us to about 10 ms. Delay LEADS or LAGS depending on the position of the ADVANCE-DELAY switch.

| | MIN | MAX |
|---------|--------|--------|
| Range 1 | 10 us | 100 us |
| Range 2 | 100 us | 1 ms |
| Range 3 | 1 ms | 10 ms |

- 4) TRIG Output. This output is used to trigger the scope time base. The output is a TTL level 100 ns (approx.) pulse capable of driving a fifty Ohm load. This output precedes the output at (5) if the two-position ADVANCE-DELAY switch is in the ADVANCE position. This output follows the output at (5) if the switch is in the DELAY position. The delay range is variable from 10 us to 10 ms. The external trigger signal is applied at this input when the MODE toggle switch is in the EXT position.
- 5) OUT Connector. BNC connector provides output to a 3 Ohm (or lower) load.
- 6) PW Control. A one turn control and 3 position range switch which varies the output pulse width from 10 us to 10 ms (when the MODE switch is in the INT position). The minimum and maximum PW for each range and the corresponding maximum PRF are as follows. Note that the unit may fail if operated at duty cycles exceeding 20%.

| | PW MIN | PW MAX |
|---------|-------------------------|-------------------------|
| Range 1 | 10 us PRF max 10 kHz | 100 us PRF max 2 kHz |
| Range 2 | 100 us PRF max 2 kHz | 1 ms PRF max 200 Hz |
| Range 3 | 1 ms PRF max 200 Hz | 10 ms PRF max 20 Hz |

- 7) AMPLITUDE. The output pulse amplitude is controlled by means of the ten turn AMP control and two position range switch as follows:

| | |
|---------|-------------|
| Range 1 | 0 to 500 mA |
| Range 2 | 0 to 5 Amps |

Note that the load voltage range (i.e. compliance voltage) of the unit is 15 Volts so the load resistance must be sufficiently low (≤ 3 Ohms) so that the load voltage does not exceed 15 Volts.

- 8) DC BIAS. A variable DC offset of 0 to 500 mA may be added to the output pulse using this one turn control.
- 9) EXT-INT-MAN Control. With the switch in the INT position, the PRF of the unit is controlled via an internal clock, which in turn is controlled by the PRF control and the output pulse width is controlled by the front panel controls. With the switch in the EXT A position, the unit requires a 50 ns (or wider) pulse applied at the TRIG input in order to trigger the output stages. In this mode, the output pulse width is controlled by the PW controls. With the MODE switch in the EXT B position, the output pulse width equals the input trigger pulse width. For single pulse operation, set the INT-EXT-MAN switch in the MAN position.
- 10) SINGLE PULSE. For single pulse manual operation, set the front panel INT-EXT-MAN switch in the MAN position and push the SINGLE PULSE button.
- 11) OPERATE-STANDBY. To obtain an output, the STANDBY-OPERATE switch must be in the OPERATE position. In the STANDBY position, a short circuit is placed across the output terminals and the output amplitude control signal is set to zero. This control may be used as a safety feature or as a means of deactivating the output.

12) **OVERLOAD**. An automatic overload protective circuit controls the front panel overload light. If the unit is overloaded (by operating at an exceedingly high duty cycle) the protective circuit will turn the output of the instrument OFF and turn the indicator light ON. The light will stay ON (i.e. output OFF) for about 5 seconds after which the instrument will attempt to turn ON (i.e. light OFF) for about 1 second. If the overload condition persists, the instrument will turn OFF again (i.e. light ON) for another 5 seconds. If the overload condition has been removed, the instrument will turn on and resume normal operation. Overload conditions may be removed by:

- 1) Reducing PRF (i.e. switch to a lower range)
- 2) Reducing pulse width (i.e. switch to a lower range)
- 3) Reducing the output amplitude

The overload light may illuminate when the prime power is first applied. The light will extinguish after a few seconds and the unit will then operate normally.

Note that the output stage will safely withstand a short-circuited load condition.

FIG. 3: BACK PANEL CONTROLS

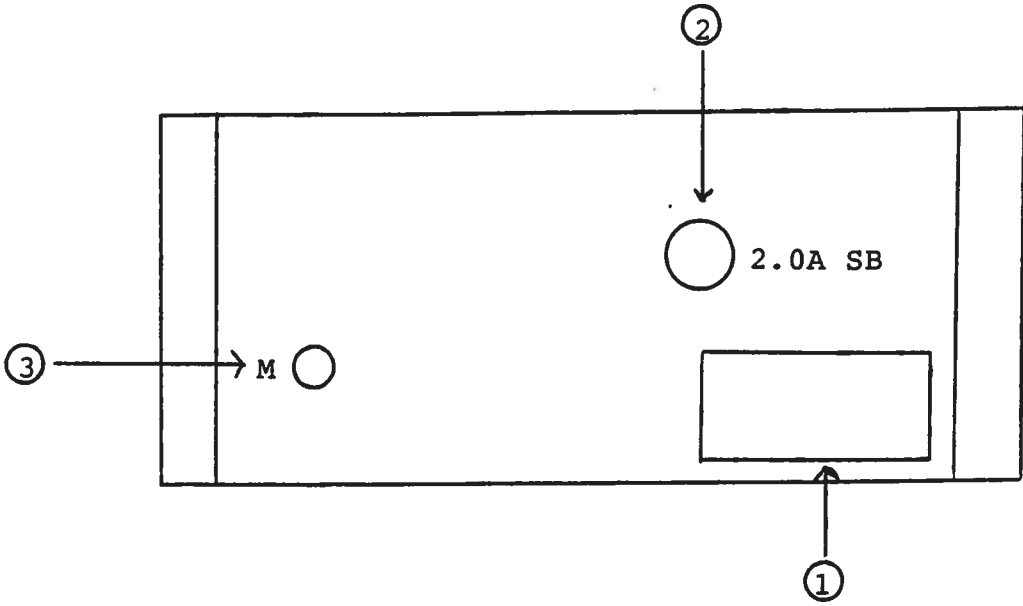

BACK PANEL CONTROLS

- 1) Power Entry Module. Detachable line cord connects to this point. Also contains voltage selector card and line fuse (1.0 A SB).
- 2) 2.0 A SB Fuse. Limits current supplied to the output stages.
- 3) CURRENT MONITOR. BNC connector provides coincident replica of the output pulse (to $R_L \geq 1K$).
 - a) $R_L \geq 1K$: $I_{LOAD} = 10 V_M$ (Volts, Amp)
 - b) $R_L = 50 \Omega$: $I_{LOAD} = 5 V_M$ (Volts, Amp)

V_M is the monitor output Volt, amplitude is determined using a scope.

TOP COVER REMOVAL AND RACK MOUNTING

- 1) The interior of the instrument may be accessed by removing the four Phillips screws on the top panel. With the four screws removed, the top cover may be slid back (and off).
- 2) The -R5 rack mount kit may be installed after first removing the one Phillips screw on the side panel adjacent to the front handle.

SYSTEM DESCRIPTION AND REPAIR PROCEDURE

The AV-156A-C unit consists of the following basic modules:

- 1) AV-156A-PG pulse generator module
- 2) +24V power supply SW -50-24)
- 3) ± 5 , ± 15 V power supply board
- 4) CLK PCB
- 5) -OL overload module

The modules are interconnected as shown in Fig. 5.

In the event of an instrument malfunction, it is most likely that the 2.0 A slow blow fuse or the main power fuse on the rear panel has blown. Replace if necessary. If the unit still does not function, it is most likely that some of the output switching elements have failed and these elements cannot be changed in the field. Therefore, the unit should be returned to AVTECH for servicing.

START-UP CHECK LIST

- 1) The instruction manual has been studied thoroughly.
- 2) Connect resistive loads ($R_L \leq 3$ Ohms) to the OUT terminal and set the STANDBY-OPERATE switch in the OPERATE position. Connect scope probes across the resistive load.
- 3) Set the pulse width delay and PRF controls at the approximate desired values. Insure that the duty cycle will be less than 20%. Set the amplitude controls fully counterclockwise.
- 4) Set the INT-EXT switch on INT.
- 5) Connect the rear panel M output to a high impedance input (1 VOLT/DIV) and connect the TRIG OUT to the scope time base.
- 6) Turn on the prime power. The scope time base should be triggering.
- 7) Gradually increase the output amplitude by rotating the amp control clockwise and observe the waveforms on the scope. A rectangular pulse should appear on the scope (for both the load voltage and monitor channels) and the amplitudes should increase as the amplitude controls are rotated clockwise.
- 8) Adjust pulse width, pulse period (i.e. PRF) and amplitude to obtain the desired settings.
- 9) Briefly set the OPERATE-STANDBY controls to the STANDBY position and note that the output voltage (and the monitor outputs) are reduced to zero.
- 10) If additional assistance is required:

Tel: (613) 226-5772

Fax: (613) 226-2802

POWER SUPPLY AND FUSE REPLACEMENT

This instrument has three fuses (plus one spare). One, which protects the AC input, is located in the rear-panel power entry module, as described in the "Rear Panel Controls" section of this manual. If the power appears to have failed, check the AC fuse first.

The other two fuses (plus one spare) are located on the internal DC power supply, as shown below:

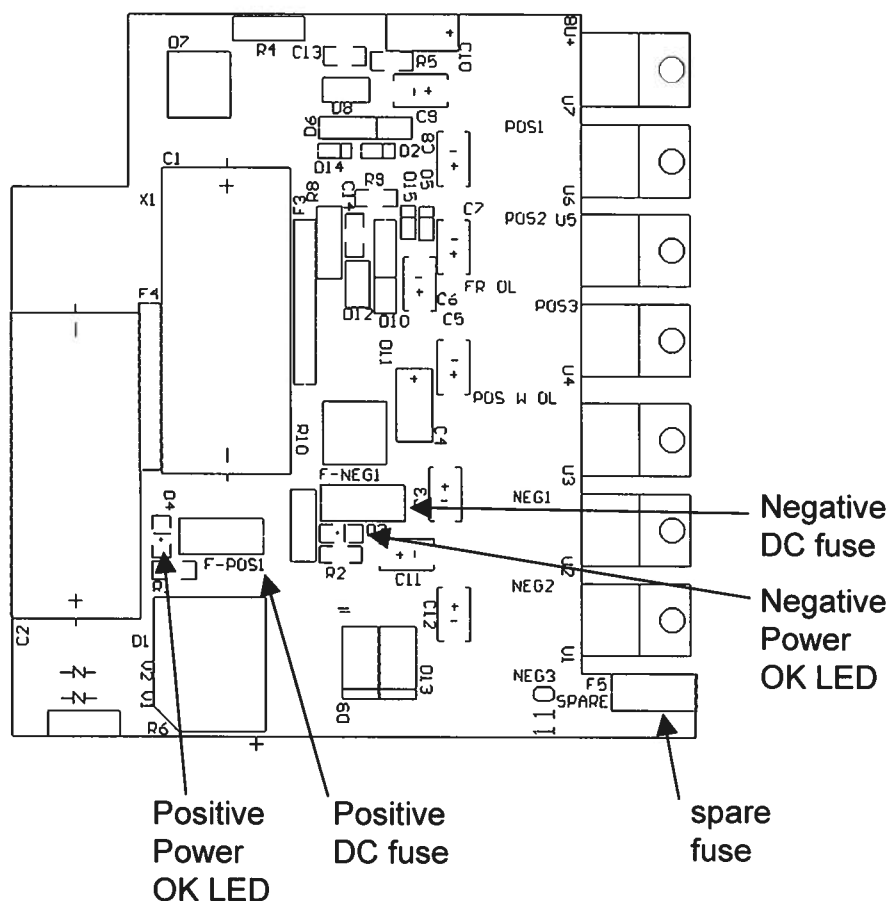

The positive fuse and the spare fuse on this circuit board are 1A slow-blow fuses, Littlefuse part number R452001. (This fuse can be ordered from Digikey, www.digikey.com. The Digikey part number is F1343CT-ND). The negative fuse is a 0.5A slow-blow fuse (Littlefuse R452.500, Digikey part number F1341CT-ND).

If you suspect that the DC fuses are blown, follow this procedure:

1. Remove the top cover, by removing the four Phillips screws on the top cover and then sliding the cover back and off.
2. Locate the two "Power OK" LEDs on the power supply circuit board, as illustrated above.
3. Turn on the instrument.
4. Observe the "Power OK" LEDs. If the fuses are not blown, the two LEDs will be lit (bright red). If one of the LEDs is not lit, the fuse next to it has blown.
5. Turn off the instrument.
6. If a fuse is blown, use needle-nose pliers to remove the blown fuse from its surface-mount holder.
7. Replace the fuse.