



AVTECH ELECTROSYSTEMS LTD.

NANOSECOND WAVEFORM ELECTRONICS
SINCE 1975

P.O. BOX 265
OGDENSBURG, NY
U.S.A. 13669-0265
TEL: (315) 472-5270
FAX: (613) 226-2802

TEL: 1-800-265-6681
FAX: 1-800-561-1970
U.S.A. & CANADA

e-mail: info@avtechpulse.com

BOX 5120 STN. F
OTTAWA, ONTARIO
CANADA K2C 3H4
TEL: (613) 226-5772
FAX: (613) 226-2802

INSTRUCTIONS

MODEL AV-156A-C-P-OP1-TMLA1 PULSED CONSTANT CURRENT GENERATOR

S.N. :

WARRANTY

Avtech Electrosystems Ltd. warrants products of its manufacture to be free from defects in material and workmanship under conditions of normal use. If, within one year after delivery to the original owner, and after prepaid return by the original owner, this Avtech product is found to be defective, Avtech shall at its option repair or replace said defective item. This warranty does not apply to units which have been disassembled, modified or subjected to conditions exceeding the applicable specifications or ratings. This warranty is the extent of the obligation or liability assumed by Avtech with respect to this product and no other warranty or guarantee is either expressed or implied.

CONTENTS

A) General Instructions Page 3

B) Front Panel Controls Page 6

C) Back Panel Controls Page 10

D) Top Cover Removal and Rack Mounting Page 12

E) System Description and Repair Procedure Page 13

F) Start-Up Check List Page 14

G) OP-1 Operating Instructions Page 15
(AN-101-AV-156A-C-P)

H) Performance Check Sheet Page 23

Fig. 1

MODEL AV-156A-C PULSE GENERATOR TEST ARRANGEMENT

(RESISTIVE LOAD)

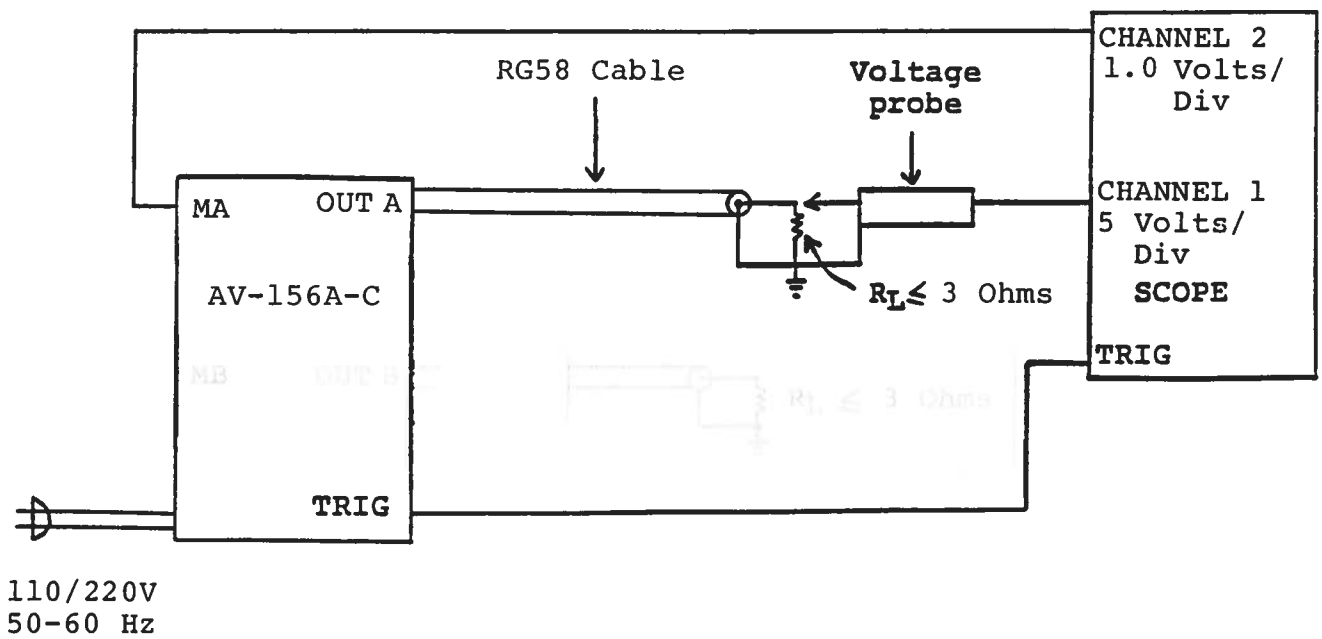

A) GENERAL OPERATING INSTRUCTIONS

- 1) For front panel manual control of the output parameters, the rear panel LOCAL-REMOTE switch must be in the LOCAL position. For remote control using a personal computer, the switch should be in the REMOTE position. See the AN-101-AV-156A-C section at the back of this manual for the instructions for this mode of operation.
- 2) The bandwidth capability of components and instruments used to display the pulse generator output signal (probes, cables, connectors, etc.) should exceed 10 MHz.
- 3) A low-inductance resistor should be used as the load. Note that an inductance of 1 uh will yield an inductance spike of about 1.5 Volts. Also note that the load resistance must not exceed 3 Ohms (for a maximum output current of 5 Amps) because the compliance voltage rating of the unit is 15 Volts. Note that to obtain an output, the STANDBY-OPERATE switches must be in the OPERATE position.
- 4) The output pulse amplitude is controlled by means of the front panel ten turn AMP control and the two position range switch as follows:

Range 1	0 to 2 Amps
Range 2	0 to 5 Amps

Note that the load voltage range (i.e. compliance voltage) of the unit is 15 Volts so the load resistance must be sufficiently low (≤ 3 Ohms) so that the load voltage does not exceed 15 Volts.
- 5) To control the unit via the internal clock, set the INT-EXT switch in the INT position. The PRF is then variable from 1 Hz to 100 Hz.

- 6) The output pulse width is controlled by means of the front panel ten turn PW control and by the PW RANGE control. Note that the MODE switch must be in the INT position. The minimum and maximum PW for each range and the corresponding maximum PRF are as follows. Note that the unit may fail if operated at duty cycles exceeding 10%.

	PW MIN	PW MAX
Range 1	1 ms PRF max 100 Hz	10 ms PRF max 10 Hz
Range 2	10 ms PRF max 10 Hz	100 ms PRF max 1 Hz

- 7) The DELAY control controls the relative delay between the reference output pulse provided at the TRIG output and the OUT port. This delay is variable over the range of 1 ms to 100 ms as follows:

	MIN	MAX
Range 1	1 ms	10 ms
Range 2	10 ms	100 ms

- 8) An external clock may be used to control the output PRF of the AV-156A unit by setting the MODE switch in the EXT position and applying a 50 ns (or wider) TTL level pulse to the TRIG BNC connector input. With the MODE switch in the EXT A position, the output pulse width will be controlled by the front panel PW controls. If the switch is in the MODE B position, the output pulse width equals the input trigger pulse width.
- 9) For single pulse manual operation, set the MODE switch in the MAN position and push the SINGLE PULSE button.
- 10) To obtain an output, the STANDBY-OPERATE switch must be in the OPERATE position. In the STANDBY position, a short circuit is placed across the output terminals and the output amplitude control signal is set to zero. This control may be used as a safety feature or as a means of deactivating the output.

11) OVERLOAD. An automatic overload protective circuit controls the front panel overload light. If the unit is overloaded (by operating at an exceedingly high duty cycle) the protective circuit will turn the output of the instrument OFF and turn the indicator light ON. The light will stay ON (i.e. output OFF) for about 5 seconds after which the instrument will attempt to turn ON (i.e. light OFF) for about 1 second. If the overload condition persists, the instrument will turn OFF again (i.e. light ON) for another 5 seconds. If the overload condition has been removed, the instrument will turn on and resume normal operation. Overload conditions may be removed by:

- 1) Reducing PRF (i.e. switch to a lower range)
- 2) Reducing pulse width (i.e. switch to a lower range)
- 3) Reducing the output amplitude

The overload light may illuminate when the prime power is first applied. The light will extinguish after a few seconds and the unit will then operate normally.

Note that the output stage will safely withstand a short circuited load condition.

12) The unit can be converted from 120 to 240V 50-60 Hz operation by adjusting the voltage selector card in the rear panel fused voltage selector-cable connector assembly.

13) For additional assistance:

Tel: (613) 226-5772
Fax: (613) 226-2802

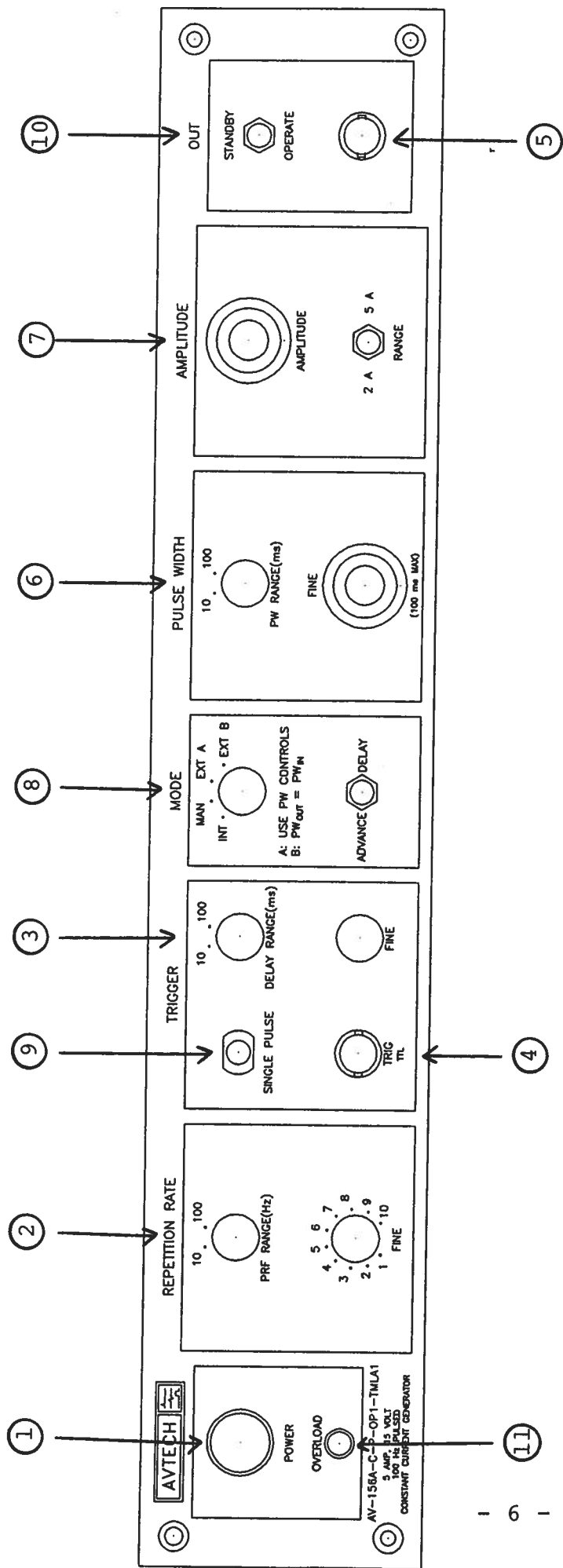

Fig. 2

FRONT PANEL CONTROLS

B) FRONT PANEL CONTROLS

- (1) ON-OFF Switch. Applies basic prime power to all stages.
- (2) PRF Control. Varies PRF from 1 Hz to 100 Hz as follows:

Range 1	1 Hz	10 Hz
Range 2	10 Hz	100 Hz

- (3) DELAY Control. Controls the relative delay between the reference output pulse provided at the TRIG output (4) and the main output (5). This delay is variable over the range of 1 ms to about 100 ms. Delay LEADS or LAGS depending on the position of the ADVANCE-DELAY switch.

	MIN	MAX
Range 1	1 ms	10 ms
Range 2	10 ms	100 ms

- (4) TRIG Output. This output is used to trigger the scope time base. The output is a TTL level 100 ns (approx.) pulse capable of driving a fifty Ohm load. This output precedes the output at (5) if the two position ADVANCE-DELAY switch is in the ADVANCE position. This output follows the output at (5) if the switch is in the DELAY position. The delay range is variable from 1 ms to 100 ms. The external trigger signal is applied at this input when the MODE toggle switch is in the EXT position.
- (5) OUT Connector. BNC connector provides output to a 3 Ohm (or lower) load.
- (6) PW Control. A ten turn control and 2 position range switch which varies the output pulse width from 1 ms to 100 ms (when the MODE switch is in the INT position). The minimum and maximum PW for each range and the corresponding maximum PRF are as follows. Note that the unit may fail if operated at duty cycles exceeding 10%.

	PW MIN	PW MAX
Range 1	1 ms PRF max 100 Hz	10 ms PRF max 10 Hz
Range 2	10 ms PRF max 10 Hz	100 ms PRF max 1 Hz

- (7) AMPLITUDE. The output pulse amplitude is controlled by means of the ten turn AMP control and two position range switch as follows:

Range 1	0 to 2 Amps
Range 2	0 to 5 Amps

Note that the load voltage range (i.e. compliance voltage) of the unit is 15 Volts so the load resistance must be sufficiently low (≤ 3 Ohms) so that the load voltage does not exceed 15 Volts.

- (8) EXT-INT-MAN Control. With the switch in the INT position, the PRF of the unit is controlled via an internal clock which in turn is controlled by the PRF control and the output pulse width is controlled by the front panel controls. With the switch in the EXT A position, the unit requires a 50 ns (or wider) pulse applied at the TRIG input in order to trigger the output stages. In this mode, the output pulse width is controlled by the PW controls. With the MODE switch in the EXT B position, the output pulse width equals the input trigger pulse width. For single pulse operation, set the INT-EXT-MAN switch in the MAN position.
- (9) SINGLE PULSE. For single pulse manual operation, set the front panel INT-EXT-MAN switch in the MAN position and push the SINGLE PULSE button.
- (10) OPERATE-STANDBY. To obtain an output, the STANDBY-OPERATE switch must be in the OPERATE position. In the STANDBY position, a short circuit is placed across the output terminals and the output amplitude control signal is set to zero. This control may be used as a safety feature or as a means of deactivating the output.

(11) OVERLOAD. An automatic overload protective circuit controls the front panel overload light. If the unit is overloaded (by operating at an exceedingly high duty cycle) the protective circuit will turn the output of the instrument OFF and turn the indicator light ON. The light will stay ON (i.e. output OFF) for about 5 seconds after which the instrument will attempt to turn ON (i.e. light OFF) for about 1 second. If the overload condition persists, the instrument will turn OFF again (i.e. light ON) for another 5 seconds. If the overload condition has been removed, the instrument will turn on and resume normal operation. Overload conditions may be removed by:

- 1) Reducing PRF (i.e. switch to a lower range)
- 2) Reducing pulse width (i.e. switch to a lower range)
- 3) Reducing the output amplitude

The overload light may illuminate when the prime power is first applied. The light will extinguish after a few seconds and the unit will then operate normally.

Note that the output stage will safely withstand a short circuited load condition.

Fig. 3

C) BACK PANEL CONTROLS

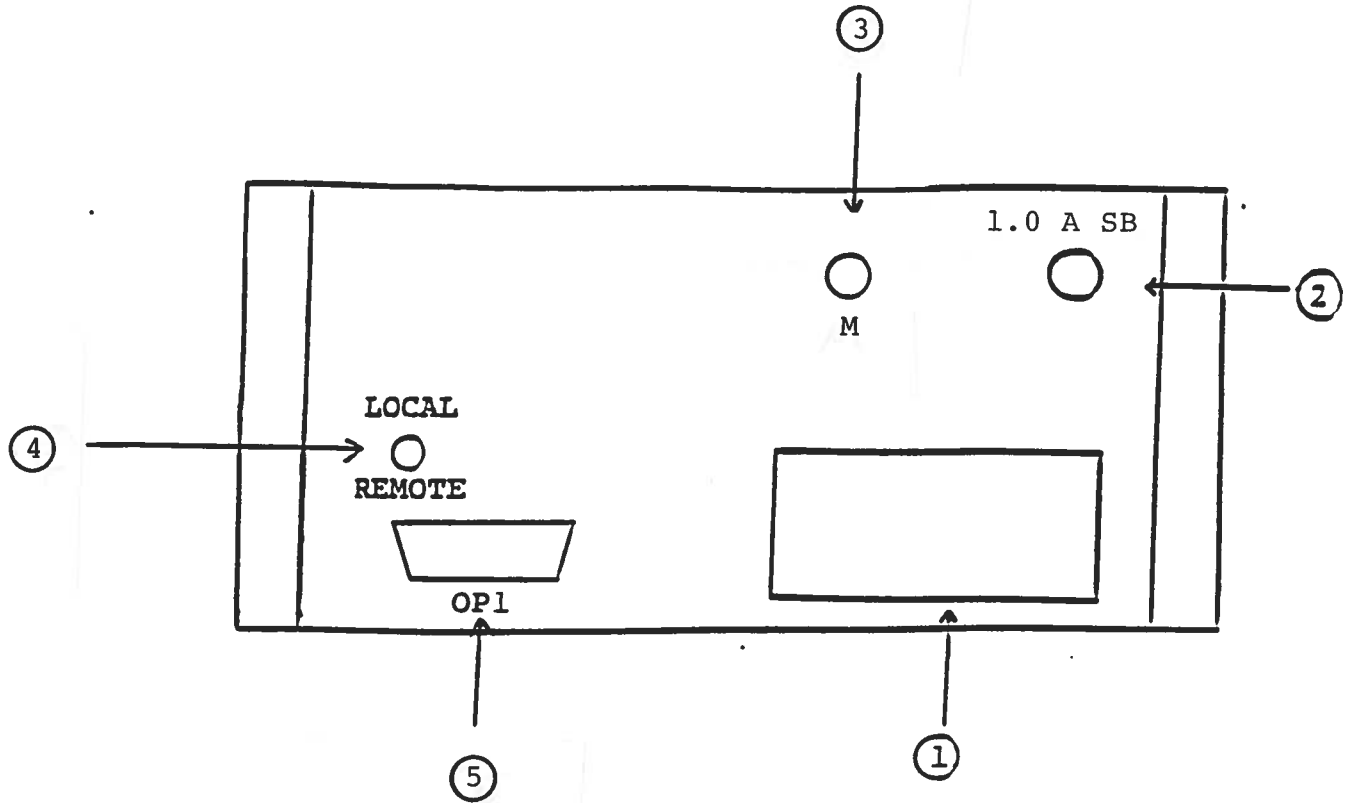

C) BACK PANEL CONTROLS

- (1) Power Entry Module. Detachable line cord connects to this point. Also contains voltage selector card and line fuse (0.50 A SB).
- (2) 1.0 A SB Fuses. Limits current supplied to the output stages.
- (3) CURRENT MONITOR. BNC connector provides coincident replica of the output pulse (to $R_L \geq 1K$).

$$I_{LOAD} = 4.55 V_M \text{ (Volts, Amp)}$$

V_M is the monitor output Volt, amplitude is determined using a scope.

- (4) For front panel manual control of the output parameters, the LOCAL-REMOTE switch must be in the LOCAL position. For remote control using a personal computer, the switch should be in the REMOTE position. See the AN-101-AV-156A-C section (at the end of this manual) for the instructions for this mode of operation. Note that it is recommended that the front panel manual mode be mastered before attempting GPIB control of the instrument.
- (5) OP1 CONNECTOR. GPIB cable (supplied) connects between this connector and your personal computer.

D) TOP COVER REMOVAL AND RACK MOUNTING

- 1) The interior of the instrument may be accessed by removing the four Phillips screws on the top panel. With the four screws removed, the top cover may be slid back (and off).
- 2) The -R5 rack mount kit may be installed after first removing the one Phillips screw on the side panel adjacent to the front handle.

E) SYSTEM DESCRIPTION AND REPAIR PROCEDURE

The AV-156A-C unit consists of the following basic modules:

- 1) AV-156A-PG pulse generator module
- 2) +24V power supply board
- 3) ± 5 , ± 15 V power supply board
- 4) OP1 PCB
- 5) OP12 PCB
- 6) -OL overload module

The modules are interconnected as shown in Fig. 5.

In the event of an instrument malfunction, it is most likely that the 1.0 A slow blow fuse or the main power fuse on the rear panel has blown. Replace if necessary. If the unit still does not function, it is most likely that some of the output switching elements have failed and these elements cannot be changed in the field. Therefore, the unit should be returned to AVTECH for servicing.

F) START-UP CHECK LIST

- 1) The instruction manual has been studied thoroughly.
- 2) Connect resistive loads ($R_L \leq 3$ Ohms) to the OUT terminal and set the STANDBY-OPERATE switch in the OPERATE position. Connect scope probes across the resistive load.
- 3) Set the pulse width delay and PRF controls at the approximate desired values. Insure that the duty cycle will be less than 10%. Set the amplitude controls fully counterclockwise.
- 4) Set the INT-EXT switch on INT.
- 5) Connect the rear panel M output to a high impedance input (1 VOLT/DIV) and connect the TRIG OUT to the scope time base.
- 6) Turn on the prime power. The scope time base should be triggering.
- 7) Gradually increase the output amplitude by rotating the amp control clockwise and observe the waveforms on the scope. A rectangular pulse should appear on the scope (for both the load voltage and monitor channels) and the amplitudes should increase as the amplitude controls are rotated clockwise.
- 8) Adjust pulse width, pulse period (i.e. PRF) and amplitude to obtain the desired settings.
- 9) Briefly set the OPERATE-STANDBY controls to the STANDBY position and note that the output voltage (and the monitor outputs) are reduced to zero.
- 10) If additional assistance is required:

Tel: (613) 226-5772

Fax: (613) 226-2802

G) OP-1 Operating Instructions (AN-101-AV-156A-C-P)

1.0 Introduction

This section describes how to use the OP-1 GPIB Bus Listener interface for remote computer control of the Avtech pulse generator, by means of the IEEE 488 General Purpose Interface Bus (GPIB).

The available commands and their structure, a typical command sequence and a sample program are included.

In addition, possible methods of incorporating remote duty cycle limit checking and instructions on how to change the GPIB address are provided

2.0 Interface to the GPIB

The IEEE 488 compatible Bus functions available to the user for GPIB control are as follows: The listed functions define a Bus Listener capability:

- SH0, AH1, T0, TE0, L2, LE0, SR0, RL0, PP0, DC1, DT0, C0.

2.1 Available Commands

The OP-1 GPIB user interface is designed to be used to remotely program the Avtech pulse generator to control the pulse repetition rate, pulse width, pulse amplitude and delayed (or advanced) trigger output.

The available command acronyms, outputs, units and range of acceptable values for the AV-156A-C-P-OP1-TMLA1 generator are defined in the table below:

Acronym	Output	Units	Range	Decades
I	Current amplitude	Amps	0 to 5	
R	Repetition rate	Hertz	1 to 100	2
W	Width of pulse	milli-sec	1 to 100	2
D	Delay (trigger)	milli-sec	1 to 100	2
A	Advance (trigger)	milli-sec	1 to 100	2
S	Single pulse			

2.1A Amplitude Range Control

Note that when the front panel AMPLITUDE RANGE switch is in the 2.0 Amp position, the peak output current is 2.5 times less than the programmed value.

OP-1 Operating Instructions

2.2 Command Interpretation

The command may utilize the defined single letter acronym, or may be expanded to a longer word to make the control program easier to understand. This is because letters following the defined acronym letter are ignored. For example, a command of "I=2" will cause exactly the same result if the command is sent as "I level of output pulse =2". However, it is mandatory that the first letter of each command be one of the five defined acronyms.

Acronyms are case insensitive, for example, "R" or "r" are the same.

The number following the acronym letter may be any number in the range specified, however, the number of significant digits are limited to one part in 255 (for 8 bits of output resolution). For example, rep rate values of 12.82, 12.83 or 12.82145 will all result in the same output. (Note that output resolution and accuracy are not necessarily the same).

Leading or trailing zeros in numbers will be ignored.

Numbers expressed in "exponential" format will NOT be interpreted correctly. For example, 3e+2 will be interpreted as 3, not as 300.

The range of the specified values must be as specified for the equipment. Numbers outside the range will be ignored.

If desired, trailing text may be added to make the control program easier to understand, since it will be ignored. For example, a command of "delay=2" will result in the same output as the command "delay = 2 milli-seconds".

The term "Delay" is used to specify the duration of the delay between the trigger output pulse and the occurrence of the actual output pulse. The term "Advance" similarly refers to the amount of time the trigger pulse will occur prior to the output pulse.

If an invalid command is sent, the unit will ignore the command and the previous value will remain unchanged. If an "out-of-range" value is sent, the unit will also ignore the command.

2.3 Typical Command Sequence Interpretation

Assume the following commands are sent using the computer, using the appropriate command structure as specified for the user's GPIB controller. Note that the default GPIB address is eight.

```
R=100  
I=3  
A=1  
W=2
```

OP-1 Operating Instructions

For example, for a GPIB controller from National Instruments, the following set of commands would be sent:

```
ibwrt "r=100"  
ibwrt "i=3"  
ibwrt "a=1"  
ibwrt "w=2"
```

This command sequence will cause the generator to produce an output pulse of width 2 milli-sec and an amplitude of 3 amps peak, repeated at a rate of 100 pulses per second. An oscilloscope attached to the generator output will confirm the result. If the generator output trigger port is used, it will be noted that each output pulse will occur 1 milli-sec after the trigger pulse occurs.

2.4 Sample Program

To illustrate the remote control process by means of the GPIB, a sample program written in BASIC is provided. While this example is prepared for use with the B&C MicroSystems PC488 circuit card, the general principles of control apply to any IEEE 488 GPIB Controller.

```
'TEST of Pulser Controller  
OPEN "PC488" FOR OUTPUT AS #1  
PRINT #1, "ABORT"  
PRINT #1, "CLEAR"  
PRINT #1, "OUTPUT 8;I", 3  
PRINT #1, "OUTPUT 8;R", 100  
PRINT #1, "OUTPUT 8;A", 1  
PRINT #1, "OUTPUT 8;W", 2  
END
```

3.0 Duty Cycle Limits

Typically, Avtech pulse generators are limited to a maximum duty cycle because of thermal constraints, where duty cycle is the ratio of Pulse Width to the reciprocal of the Repetition Rate (i.e.; $R \times W$). Although the generator contains automatic protection against an excessive duty cycle, whenever this protection is activated, the output is inhibited. Therefore, it may be desirable to have the control computer calculate the duty ratio, then generate a warning message to the operator whenever the limits are exceeded (preferably prior to actually sending the command sequence).

This message could caution the user either to reduce the repetition rate or the pulse width, to avoid thermal overload.

While this calculation is not mandatory, it could avoid the annoyance of automatic inhibiting of the generator output.

OP-1 Operating Instructions

4.0 Changing the Unit GPIB Address

Since the GPIB data bus address for the pulse generator has been preset to "8" in the factory, commands are required to be sent to this address. However, the user may wish to change the address to any address in the allowed range of 0 to 30. This address may be easily changed by re-setting the GPIB address switch on the GPIB Interface board located inside the pulse generator chassis.

The address is set by means of a five position "Dipswitch " located on the top of a small circuit card located inside the enclosure near the top rear. The switch may be observed to be set to the default address by noting that the Dipswitch position 4 is set in the OFF position, defining a binary address of 8.

The switch setting is calculated as the sum of the switch weights in the OFF position, calculated as follows: (a switch in the ON position it has a weight of zero):

Switch Number	OFF Weight
1	1
2	2
3	4
4	8
5	16

For example, a switch with positions 1, 4 and 5 set to OFF will result in an address setting of 25 (16 plus 8 plus 1 = 25).

5.0 Trouble-Shooting Aid

In the event that difficulties are encountered communicating via the GPIB interface, two auxiliary communications status indicators have been included on the GPIB interface circuit card. These status indicators are small LED lamps, one which flashes briefly whenever a properly addressed command is received. The second LED will light whenever an out-of-range value or invalid command is received, and will remain lit until a valid command with a valid in-range value is subsequently received.



AVTECH ELECTROSYSTEMS LTD.

NANOSECOND WAVEFORM ELECTRONICS
SINCE 1975

☐ P.O. BOX 265
OGDENSBURG, NY
U.S.A. 13669-0265
TEL: (315) 472-5270
FAX: (613) 226-2802

TEL: 1-800-265-6681
FAX: 1-800-561-1970
e-mail: info@avtechpulse.com
<http://www.avtechpulse.com>

☒ P.O. BOX 5120 STN. F
OTTAWA, ONTARIO
CANADA K2C 3H4
TEL: (613) 226-5772
FAX: (613) 226-2802

March 18, 1997.

Craig King
Takata Moses Lake Inc.
9138 Randolph Road N.E.
Moses Lake, WA 98837

Dear Craig:

Following our telephone conversation of March 17th, I am pleased to provide the following revised price and delivery quotation:

Model designation: AV-156A-C-P-OP1-TMLA1.

Output amplitude: 2A Range:
0 to 2 Amps. Controlled by a ten turn front panel control or by the -OP1 GPIB bus (8 bit control, 256 steps).

5A Range:
0 to 5 Amps. Controlled by a ten turn front panel control. GPIB will control output but output amplitude will be 2.5 times programmed value since OP1 option has only one amplitude range.

Output pulse width: 1 to 100 ms. Controlled by a two position range switch and a ten turn control or by the GPIB bus.

Load voltage range: 0 to +15 Volts.

Output current regulation: $\leq 1\%$ for load voltage change from +15 to 0 Volts.

.../2

Pulse repetition frequency: Internal trigger: 1 Hz to 100 Hz. Controlled by a two position range switch and one turn control or by the GPIB bus. GPIB bus will also provide single pulse operation.

External trigger: 0 to 100 Hz TTL.

Manual trigger: Manual push button of single pulse operation.

Rise, fall time: ≤ 10 us.

Maximum duty cycle: 10%.

Monitor output: Provides a voltage output pulse which is a replica of the output current pulse.

GPIB control: The -OP1 GPIB function is described on page 8 of Cat. No. 9.

Dimensions: (H x W x D) 100 mm x 430 mm x 375 mm (3.9" x 17" x 14.8").

Face plate: See attached drawing.

Chassis material: Aluminum. Anodized aluminum front panel with cast aluminum side panels (with gray plastic trim) and aluminum top and bottom panels with gray plastic trim (chassis is as per our Model AV-1010-C).

Connectors: BNC.

Rack mounting: Includes -R5 rack mount kit for 19" rack mounting.

Prime power: 120/240V, 50-60 Hz.

Price: \$4,198.00 US each, FOB destination.

Delivery: 60 days ARO.

Our more advanced OP1B GPIB bus (see page 8) will be available in July of 1997. This unit has 12 bit control of the amplitude (4096 steps).

Price and delivery for this version are as follows:

Model designation: AV-156A-C-P-OP1B-TMLA.
Price: \$4,988.00 US each, FOB destination.
Delivery: 60-90 days ARO.

Thank you for your continuing interest in our products.
Please call me again (1-800-265-6681) if you require any
additional information or modifications to the above quotation.

Yours truly,

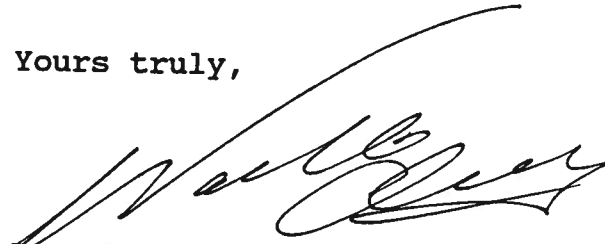

Dr. Walter Chudobiak
Chief Engineer

WC:pr
Encl. AV-156A-C-OP1-TMLA1 face plate drawing

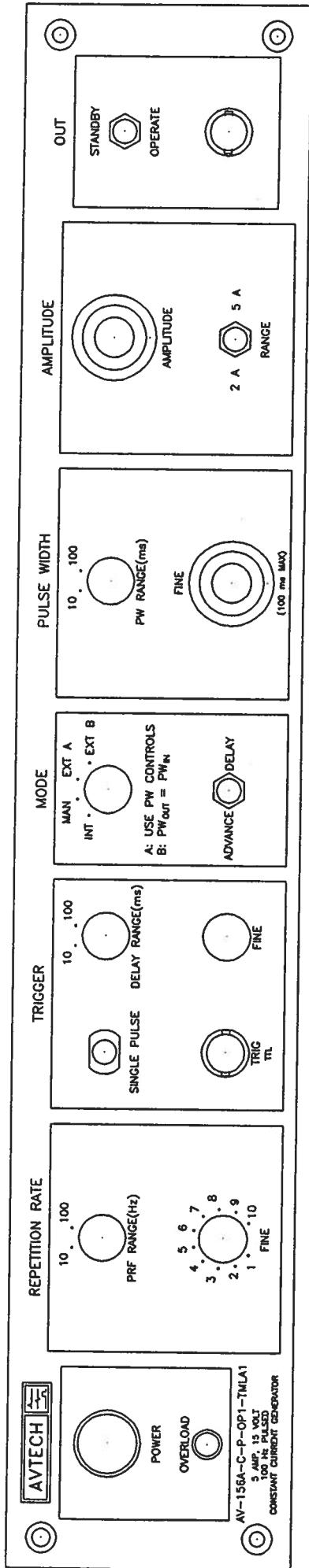

May 9/97

-R5

Disk: AV-150

Name: 56ACOP1T.INS