



AVTECH ELECTROSYSTEMS LTD.

NANOSECOND WAVEFORM ELECTRONICS
SINCE 1975

P.O. BOX 265
OGDENSBURG, NY
U.S.A. 13669-0265
TEL: (315) 472-5270
FAX: (613) 226-2802

TEL: 1-800-265-6681
FAX: 1-800-561-1970

e-mail: info@avtechpulse.com
<http://www.avtechpulse.com>

P.O. BOX 5120 STN. F
OTTAWA, ONTARIO
CANADA K2C 3H4
TEL: (613) 226-5772
FAX: (613) 226-2802

obsolete

INSTRUCTIONS

MODEL AV-156A-C-P-OP1B-ISIA

0 to 5 AMP, 0 to +25 V, 10 μ s RISE TIME

**DUAL CHANNEL
PULSED CONSTANT CURRENT GENERATOR**

WITH IEEE 488.2 AND RS-232 CONTROL

SERIAL NUMBER: _____

WARRANTY

Avtech Electrosystems Ltd. warrants products of its manufacture to be free from defects in material and workmanship under conditions of normal use. If, within one year after delivery to the original owner, and after prepaid return by the original owner, this Avtech product is found to be defective, Avtech shall at its option repair or replace said defective item. This warranty does not apply to units which have been disassembled, modified or subjected to conditions exceeding the applicable specifications or ratings. This warranty is the extent of the obligation assumed by Avtech with respect to this product and no other warranty or guarantee is either expressed or implied.

TECHNICAL SUPPORT

Phone: 613-226-5772 or 1-800-265-6681

Fax: 613-226-2802 or 1-800-561-1970

E-mail: info@avtechpulse.com

World Wide Web: <http://www.avtechpulse.com>

TABLE OF CONTENTS

WARRANTY	2
TECHNICAL SUPPORT	2
INTRODUCTION	4
SPECIFICATIONS	5
INSTALLATION	6
VISUAL CHECK	6
PLUGGING IN THE INSTRUMENT	6
FRONT PANEL CONTROLS	7
REAR PANEL CONTROLS	9
GENERAL INFORMATION	11
BASIC PULSE CONTROL	11
MONITOR CIRCUIT	12
TRIGGER MODES	12
GATING MODES	13
TOP COVER REMOVAL	13
RACK MOUNTING	14
LOAD PROTECTION	15
LENZ'S LAW AND INDUCTIVE VOLTAGE SPIKES	15
OUTPUT ON/OFF	15
ATTACHING AND DETACHING LOADS	15
OPEN AND SHORT CIRCUITS	15
OPERATIONAL CHECK	16
USER-ACCESSIBLE INTERNAL CALIBRATION ADJUSTMENTS	19
NULLING CONSTANT CURRENT OFFSETS	19
NULLING AMPLITUDE-DEPENDENT CURRENT OFFSETS	20
NULLING CONSTANT MONITOR OFFSETS	20
ADJUSTING OUTPUT IMPEDANCE	20
ADJUSTING MONITOR CALIBRATION	20
PROGRAMMING YOUR PULSE GENERATOR	21
KEY PROGRAMMING COMMANDS	21
ALL PROGRAMMING COMMANDS	21
PERFORMANCE CHECK SHEET	24

INTRODUCTION

The Model AV-156A-C-P-OP1B-ISIA pulsed constant current generator is capable of producing two channels of rectangular pulses with amplitudes as high as 5 Amperes into load voltages up to 25V, with $< 10 \mu\text{s}$ rise and fall times. The internal trigger source can be used to trigger the instrument at frequencies between 1 and 100 Hz. An external TTL trigger pulse, a front-panel pushbutton, and a computer can also be used to trigger the instrument. The maximum duty cycle is 10%.

This instrument has two output channels. The pulses on one channel may be delayed up to $\pm 100\text{ms}$ with respect to the pulses on the other channel.

The Model AV-156A-C-P-OP1B-ISIA pulse generator is a current pulser. The current amplitude is largely independent of the load voltage. For proper operation, the load voltage ($V_{\text{LOAD}} = I_{\text{LOAD}} \times R_{\text{LOAD}}$) must lie in the range of 0 to +25V.

The AV-156A-C-P-OP1B-ISIA features front panel keyboard and adjust knob control of the output pulse parameters along with a four line by 40 character back-lit LCD display of the output amplitude, pulse width, pulse repetition frequency, and delay. The instrument includes memory to store up to four complete instrument setups. The operator may use the front panel or the computer interface to store a complete "snapshot" of all key instrument settings, and recall this setup at a later time.

SPECIFICATIONS

Model:	AV-156A-C-P-OP1B-ISIA
Channels:	Two
Amplitude:	0 to +5 Amperes, for load voltages of 0 to +25 Volts
Pulse width:	1 to 100 ms
Rise time:	$\leq 10 \mu\text{s}$
Fall time:	$\leq 10 \mu\text{s}$
PRF:	internal trigger: 1 to 100 Hz external or pushbutton trigger: $\leq 100 \text{ Hz}$
Max. duty cycle:	10%
Output current regulation:	$\leq 2\%$ for load change from 25V to 0V
Trigger required: (external trigger mode)	Internal PW Mode: +5 Volt, 50 ns or wider (TTL)
Monitor output:	Provides an attenuated coincident replica of the main output current pulse. $V_{\text{MON}} = I_{\text{LOAD}} \times 1 \Omega$
Inter-channel delay:	0 to $\pm 100 \text{ ms}$
Sync output:	+ 5 Volts, 200 ns wide, will drive 50 Ohm loads, coincident with pulses on Channel 2
Connectors:	Out 1, Out 2, Gate, Trig, Sync, Monitor 1, Monitor 2: BNC
Power, AC:	120/240 Volts (switchable) 50 - 60 Hz
Dimensions:	3.9" x 19" x 14.8"
Chassis material:	anodized aluminum, with blue plastic trim
Mounting:	Any
Temperature range:	+ 10° to + 40° C

INSTALLATION

VISUAL CHECK

After unpacking the instrument, examine to ensure that it has not been damaged in shipment. Visually inspect all connectors, knobs, liquid crystal displays (LCDs), and the handles. Confirm that a power cord and two instrumentation manuals (this manual and the "OP1B Interface Programming Manual") are with the instrument. If the instrument has been damaged, file a claim immediately with the company that transported the instrument.

PLUGGING IN THE INSTRUMENT

Examine the rear of the instrument. There will be a male power receptacle, a fuse holder and the edge of the power selector card visible. Confirm that the power selector is in the correct orientation - it should be marked either 120 or 240, indicating whether it expects 120V AC or 240V AC. If it is not set for the proper voltage, remove the fuse and then grasp the card with a pair of pliers and remove it. Rotate horizontally through 180 degrees. Reinstall the card and the correct fuse. In the 120V setting, a 2A slow blow fuse is required. In the 240V setting, a 1A slow blow fuse is required.

FRONT PANEL CONTROLS

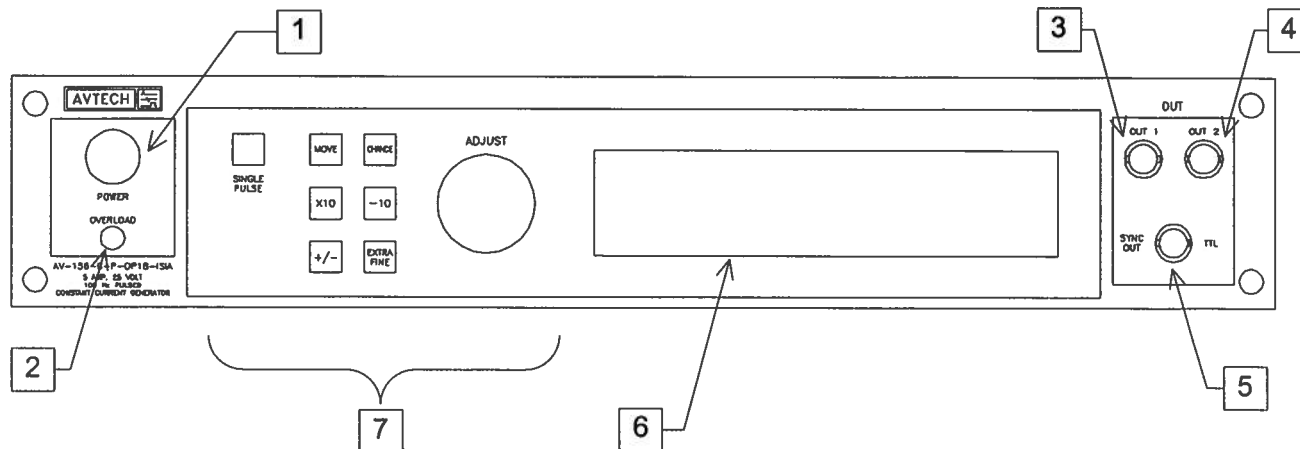

1. **POWER Switch.** The POWER push button switch applies AC prime power to the primaries of the transformer, turning the instrument on. The push button lamp (#382 type) is connected to the +15V DC supply.
2. **OVERLOAD.** The AV-156A-C-P-OP1B-ISIA is protected in its internal software against conflicting or dangerous settings. As an additional protective measure, an automatic overload circuit exists, which controls the front panel overload light. If the internal power supply is overloaded due to improper operation, the protective circuit will turn the output of the instrument OFF and turn the indicator light ON. The light will stay ON (i.e. output OFF) for about 5 seconds after which the instrument will attempt to turn ON (i.e. light OFF) for about 1 second. If the overload condition persists, the instrument will turn OFF again (i.e. light ON) for another 5 seconds. If the overload condition has been removed, the instrument will turn on and resume normal operation.

The overload indicator may come on briefly at startup. This is not a cause for concern.
3. **OUT 1 CONNECTOR.** This BNC connector provides the Channel 1 output signal.
4. **OUT 2 CONNECTOR.** This BNC connector provides the Channel 2 output signal.
5. **SYNC OUT.** This connector supplies a SYNC output that can be used to trigger other equipment, particularly oscilloscopes. This pulse is coincident with pulses on Channel 2. The sync output has an approximate amplitude of +3 Volts to $R_L > 1K$ with a pulse width of approximately 200 ns.
6. **LIQUID CRYSTAL DISPLAY (LCD).** This LCD is used in conjunction with the keypad to change the instrument settings. Normally, the main menu is displayed, which lists the key adjustable parameters and their current values. The "OP1B

Interface Programming Manual" describes the menus and submenus in detail.

7. KEYPAD.

Control Name	Function
MOVE	This moves the arrow pointer on the display.
CHANGE	This is used to enter the submenu, or to select the operating mode, pointed to by the arrow pointer.
×10	If one of the adjustable numeric parameters is displayed, this increases the setting by a factor of ten.
÷10	If one of the adjustable numeric parameters is displayed, this decreases the setting by a factor of ten.
+/-	If one of the adjustable numeric parameters is displayed, and this parameter can be both positive or negative, this changes the sign of the parameter.
EXTRA FINE	This changes the step size of the ADJUST knob. In the extra-fine mode, the step size is twenty times finer than in the normal mode. This button switches between the two step sizes.
ADJUST	This large knob adjusts the value of any displayed numeric adjustable values, such as frequency, pulse width, etc. The adjust step size is set by the "EXTRA FINE" button. When the main menu is displayed, this knob can be used to move the arrow pointer.

REAR PANEL CONTROLS

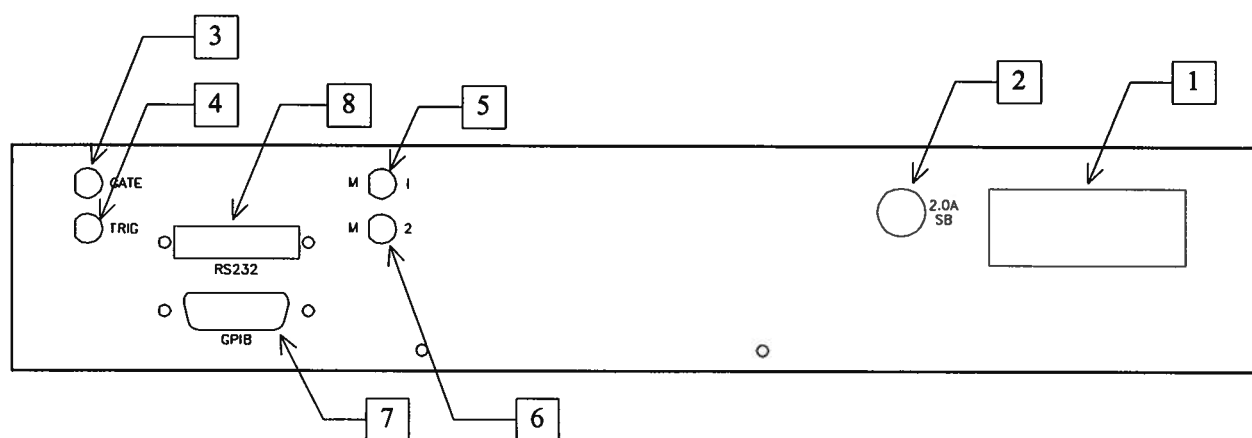

1. **AC POWER INPUT.** A three-pronged recessed male connector is provided on the back panel for AC power connection to the instrument. Also contained in this assembly is a 2.0A slow blow fuse and a removable card that can be removed and repositioned to switch between 120V AC in and 240V AC in.
2. **2.0A SB.** This fuse protects the internal +35V DC power supply.
3. **GATE.** This TTL-level (0 and +5V) logic input can be used to gate the triggering of the instrument. This input can be either active high or active low, depending on the front panel settings or programming commands. (The instrument triggers normally when this input is unconnected).
4. **TRIG.** This TTL-level (0 and +5V) logic input can be used to trigger the instrument, if the instrument is set to triggering externally. The instrument triggers on the rising edge of this input.
5. **M 1.** This is a current monitor output. This output provides a voltage waveform that is proportional to the current waveform on the Channel 1 output. The monitor relationship is: $V_{MON} = 1\Omega \times I_{OUT}$, for a load of $> 1\text{ k}\Omega$. (The monitor output can also drive a 50Ω load, but the output voltage will be reduced by a factor of two. This output is short-circuit protected.)
6. **M 2.** This is a current monitor output. This output provides a voltage waveform that is proportional to the current waveform on the Channel 2 output. The monitor relationship is: $V_{MON} = 1\Omega \times I_{OUT}$, for a load of $> 1\text{ k}\Omega$. (The monitor output can also drive a 50Ω load, but the output voltage will be reduced by a factor of two. This output is short-circuit protected.)
7. **GPIB Connector.** A standard GPIB cable can be attached to this connector to allow the instrument to be computer-controlled. See the "OP1B Interface Programming Manual" for more details on GPIB control.

8. RS-232 Connector. A standard serial cable with a 25-pin male connector can be attached to this connector to allow the instrument to be computer-controlled. See the "OP1B Interface Programming Manual" for more details on RS-232 control.

GENERAL INFORMATION

BASIC PULSE CONTROL

This instrument can be triggered several sources - its own internal clock, an external TTL trigger signal, the front-panel "SINGLE PULSE" pushbutton, or by a computer-generated command. In any case, five output channels respond to the trigger: OUT1, OUT2, SYNC, M1, and M2. OUT1 and OUT2 are the signals that are applied to the devices under test. Their amplitudes and pulse widths are variable. The SYNC pulse is a fixed-width TTL-level reference pulse used to trigger oscilloscopes or other measurement systems, and is coincident with the OUT2 pulse. The M1 and M2 outputs are voltage waveforms that are proportional to the current waveforms on OUT1 and OUT2, respectively. $V_{M1} = 1\Omega \times I_{OUT1}$ and $V_{M2} = 1\Omega \times I_{OUT2}$ for monitor loads of > 1 k Ω .

When the delay is set to a positive value the OUT2 and SYNC pulses precede the channel 1 pulse. This order is reversed for negative delays.

These pulses are illustrated below for a positive delay:

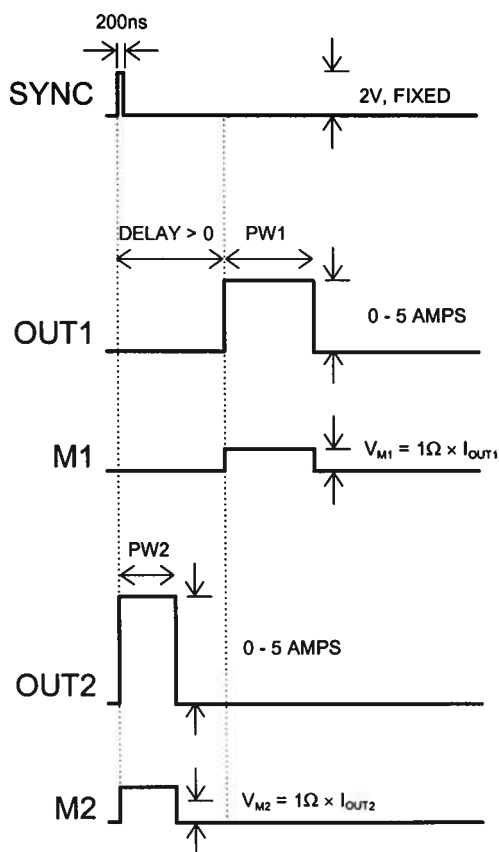

Basic Output Pulses for Delay > 0

The order of the output pulses is reversed for negative delays:

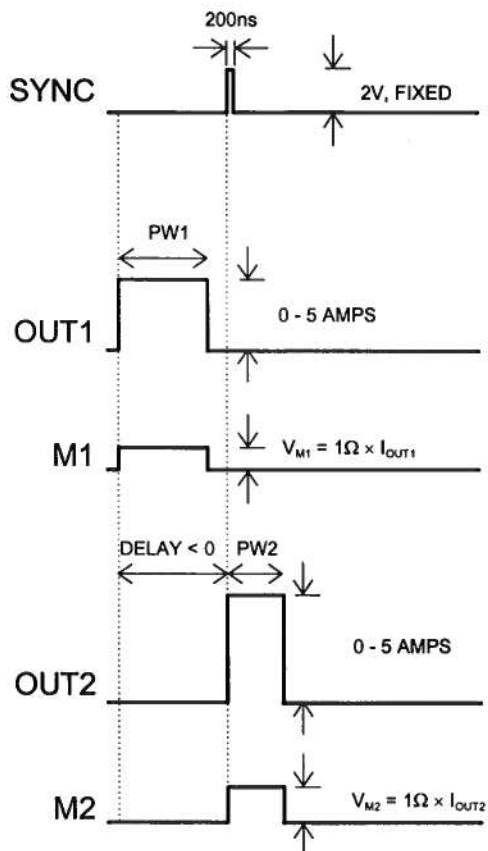

Basic Output Pulses for Delay < 0

The delay, pulse width, and frequency (when in the internal mode), of the OUT pulse can be varied with front panel controls or via the GPIB or RS-232 computer interfaces.

MONITOR CIRCUIT

As noted in the previous section, a current monitor outputs are available. The current monitor output also measures amplitude of the most recent pulse, in amperes, and displays it on the front panel LCD.

TRIGGER MODES

This instrument has four front-panel trigger modes:

- Internal Trigger: the instrument controls the trigger frequency, and generates the clock internally.
- External Trigger: the instrument is triggered by an external TTL-level clock on the back-panel TRIG connector.

- Manual Trigger: the instrument is triggered by the front-panel "SINGLE PULSE" pushbutton.
- Hold Trigger: the instrument is set to not trigger at all.

These modes can be selected using the front panel trigger menu, or by using the appropriate programming commands. (See the "OP1B Interface Programming Manual" for more details.)

When being controlled by a computer, there is a fifth trigger mode:

- Immediate Trigger: generates a single trigger event. This is the computer-control equivalent of pressing the front-panel "SINGLE PULSE" pushbutton.

GATING MODES

Triggering can be suppressed by a TTL-level signal on the rear-panel GATE connector. The instrument can be set to stop triggering when this input high or low, using the front-panel gate menu or the appropriate programming commands.

This gate signal acts synchronously - i.e., when gated, the output will complete the full pulse width if the output is high, and then stop triggering. No pulses are truncated in this mode.

AVOID EXCESS POWER DISSIPATION

To prolong the life of the output stages of the instrument, the internal power dissipation should be minimized whenever practical. The power dissipated in each of the two output stages can be calculated using:

$$P_{DISS} = (35 \text{ Volts} - V_{LOAD}) \times I_{PEAK} \times \text{Duty Cycle}$$

To minimize power dissipation, keep the current amplitude and duty cycle as low as practical. Operation into larger load resistance is preferred over operation into a low load resistance, since $V_{LOAD} = I_{PEAK} \times R_{LOAD}$.

TOP COVER REMOVAL

The top cover of the instrument may be removed by removing the four Phillips screws on the top panel. With these four screws removed, the top panel may be slid off by pulling it towards the rear.

The instrument should not be accessed internally unless it has been turned off for ten minutes, to allow all internal capacitors to discharge. The internal capacitor bank stores a considerable amount of energy.

RACK MOUNTING

A rack mounting kit is available. The -R5 rack mount kit may be installed after first removing the one Phillips screw on the side panel adjacent to the front handle.

LOAD PROTECTION

LENZ'S LAW AND INDUCTIVE VOLTAGE SPIKES

This instrument is designed to pulse resistive and diode loads and will exhibit a large output spike when used to drive a load with significant inductance (as predicted by LENZ'S LAW). For this reason the load should be connected to the output using low inductance leads (as short as possible and as heavy a gauge as possible).

The voltage developed across an inductance L (in Henries), when the current is changing at a rate given by di_{LOAD}/dt (in Amps/sec), is: $V_{SPIKE} = L \frac{di_{LOAD}}{dt}$.

OUTPUT ON/OFF

The main outputs may be switched on and off using the front-panel controls or via programming commands. When the output is set "OFF", the main outputs are short-circuited to ground with a relay, and the trigger source is removed from the output stage.

ATTACHING AND DETACHING LOADS

To avoid damaging the loads connected to main outputs, the loads should only be connected to or removed from the instrument when:

- the instrument is off
- the instrument is on, but the outputs are turned off (i.e. the LCD display reads "OUTPUT OFF")

Do not connect loads when the instrument is on and the outputs are turned on. This can cause mild sparking.

CHANGING PARAMETERS WHEN A LOAD IS ATTACHED

If your load is easily damaged, the outputs should be turned off when changing the trigger source, frequency, pulse width, or other pulse parameters. This protects the loads from possible short transient effects.

OPEN AND SHORT CIRCUITS

The AV-156A-C-P-OP1B-ISIA will operate properly into a short circuit to ground.

Operation into an open circuit will not damage the instrument in any way, although the monitor circuit may not give the correct reading (which should be zero).

OPERATIONAL CHECK

This section describes a sequence to confirm the basic operation of the instrument. It should be performed after receiving the instrument. It is a useful learning exercise as well.

Before proceeding with this procedure, finish reading this instruction manual thoroughly. Then read the "Local Control" section of the "OP1B Interface Programming Manual" thoroughly. The "Local Control" section describes the front panel controls used in this operational check - in particular, the MOVE, CHANGE, and ADJUST controls.

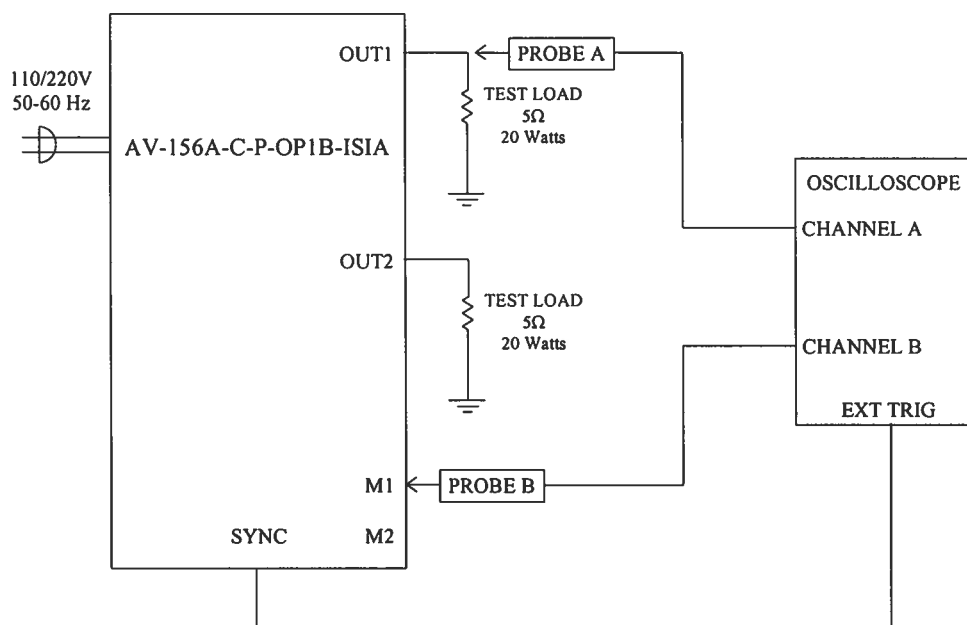

Basic Test Arrangement

- 1) Connect a 20W, 5Ω test load between the OUT1 connector and ground.
- 2) Connect a 20W, 5Ω test load between the OUT2 connector and ground.
- 3) Connect a cable from the SYNC OUT connector to the TRIG input of an oscilloscope. Set the oscilloscope to trigger externally.
- 4) Connect one oscilloscope probe (channel A) to the OUT1 load. Connect the other probe to the M1 output (on the rear panel). On the oscilloscope, set the channel A vertical scale to 10 V/div, the channel B vertical scale to 2 V/div, and the horizontal scale to 1 ms/div.
- 5) Turn on the AV-156A-C-P-OP1B-ISIA. The instrument will execute a warm-up sequence for 45 seconds, during which time the internal capacitor banks are charged. Wait for this sequence to complete. After this delay, the main menu will appear on the LCD.

- 6) To set the AV-156A-C-P-OP1B-ISIA to trigger from the internal clock at a PRF of 30 Hz:
- The arrow pointer should be pointing at the frequency menu item. If it is not, press the MOVE button until it is.
 - Press the CHANGE button. The frequency submenu will appear. Rotate the ADJUST knob until the frequency is set at 30 Hz.
 - The arrow pointer should be pointing at the "Internal" choice. If it is not, press MOVE until it is.
 - Press CHANGE to return to the main menu.
- 7) To set the delay to 2 ms:
- Press the MOVE button until the arrow pointer is pointing at the delay menu item.
 - Press the CHANGE button. The delay submenu will appear. Rotate the ADJUST knob until the delay is set at 2 ms.
 - Press CHANGE to return to the main menu.
- 8) To set the OUT1 pulse width to 1.5 ms:
- Press the MOVE button until the arrow pointer is pointing at the "PW1" menu item.
 - Press the CHANGE button. The pulse width submenu will appear. Rotate the ADJUST knob until the pulse width is set at 1.5 ms.
 - The arrow pointer should be pointing at the "Normal" choice. If it is not, press MOVE until it is.
 - Press CHANGE to return to the main menu.
- 9) To set the OUT2 pulse width to 2 ms:
- Press the MOVE button until the arrow pointer is pointing at the "PW2" menu item.
 - Press the CHANGE button. The pulse width submenu will appear. Rotate the ADJUST knob until the pulse width is set at 2 ms.

- The arrow pointer should be pointing at the “Normal” choice. If it is not, press MOVE until it is.
- Press CHANGE to return to the main menu.

10) At this point, nothing should appear on the oscilloscope.

11) To enable the output:

- Press the MOVE button until the arrow pointer is pointing at the output menu item.
- Press the CHANGE button. The output submenu will appear.
- Press MOVE until the arrow pointer is pointing at the “ON” choice.
- Press CHANGE to return to the main menu.

12) To change the OUT1 output amplitude:

- Press the MOVE button until the arrow pointer is pointing at the AMP1 menu item.
- Press the CHANGE button. The amplitude submenu will appear. Rotate the ADJUST knob until the amplitude is set at 5A.
- Observe the oscilloscope. You should see 1.5 ms wide, 25V pulses (i.e., $5A \times 5\Omega = 25V$) on the probe connected to the OUT1 main output. The other probe, connected to the M1 monitor output, should show 1.5ms, 5V pulses (i.e. $5A \times 1V/A$).
- Press CHANGE to return to the main menu.

13) Try varying the pulse width, by repeating step (8). As you rotate the ADJUST knob, the pulse width on the oscilloscope will change. It should agree with the displayed value. Stay below 10% duty cycle.

14) Move the oscilloscope probes from OUT1 and M1 to OUT2 and M2, respectively, and repeat steps 12 and 13 using the AMP2 and PW2 menus to change the second channel output.

15) This completes the operational check.

If additional assistance is required:

Tel: (613) 226-5772, Fax: (613) 226-2802
Email: info@avtechpulse.com

USER-ACCESSIBLE INTERNAL CALIBRATION ADJUSTMENTS

Each output channel has five trimming potentiometers ("trimpots") that can be used to adjust the performance of the output channels. These trimpots are preset at the factory and should not normally require adjusting after delivery. These controls can be accessed by removing the top panel of the instrument, and by locating the two identical output-stage modules. When looking from the front of the instrument, the channel 1 module is on the left and the channel 2 module is on the right. Both are near the rear of the instrument.

The locations of the trimpots (designated TP1-TP5) for each channel are shown below. All should be accessible through the heatsinking.

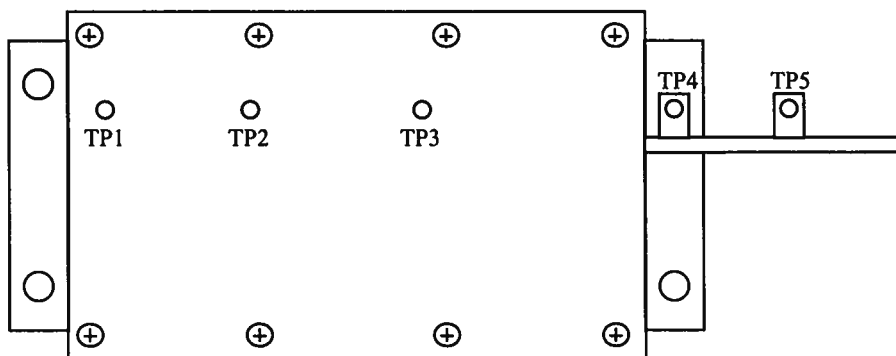

Location of Trimpots

These trimpots can be used to adjust or calibrate the following properties for each channel:

1. Current offsets on the main outputs.
2. Voltage offsets on the monitor outputs.
3. Monitor calibration.
4. Channel output impedance.

NULLING CONSTANT CURRENT OFFSETS

If a small constant current offset is observed on one of the main outputs, TP2 can be rotated to reduce it to zero. Note that the output stage is incapable of generating a negative current, due to the presence of a diode in series with the output.

NULLING AMPLITUDE-DEPENDENT CURRENT OFFSETS

If a small amplitude-dependent current offset is observed on one of the main outputs, TP1 can be rotated to null it out. Rotate TP1 while adjusting the output amplitude from the front panel, until the offset does not vary with amplitude.

NULLING CONSTANT MONITOR OFFSETS

If a small constant voltage offset is observed on one of the monitor outputs, TP5 can be rotated to reduce it to zero.

ADJUSTING OUTPUT IMPEDANCE

Ideally, the outputs of the pulsed current sources should be independent of the output voltages, within the 0 to +25V compliance voltage range. This condition represents infinite output impedance. If a load voltage/output current dependence is present, the output impedance needs to be adjusted.

To adjust the output impedance, connect a 20W, 5.0Ω load to the output to be adjusted. Set the output amplitude to 5A and observe the load voltage on an oscilloscope. The load voltage should have an amplitude of approximately 25V (i.e. $5\text{A} \times 5\Omega = 25\text{V}$). Note the exact value. Now replace the 5.0Ω load with a 2.5Ω load. The load voltage should fall by to approximately 12.5V (i.e. $5\text{A} \times 2.5\Omega = 12.5\text{V}$). Note the exact value. If the second voltage is not exactly one-half of the first voltage, adjust TP3 and repeat *both* measurements (5.0Ω and 2.5Ω) again. Repeat as required.

ADJUSTING MONITOR CALIBRATION

Just as the current amplitude of the main outputs can exhibit a load-voltage dependence, the voltage amplitude of the current monitors can also exhibit such a dependence if not adjusted properly.

To null out the monitor load voltage dependence, connect a 20W, 5.0Ω load to the main output to be adjusted (i.e. OUT1 or OUT2). Set the output amplitude to 5A and observe the monitor voltage (i.e. M1 or M2) on an oscilloscope. The monitor voltage should have an amplitude of approximately 5V (i.e. $5\text{A} \times 1\text{ V/A} = 5\text{V}$). Note the exact value. Now replace the 5.0Ω load with a 2.5Ω load. The monitor voltage not change, since the current amplitude has not changed (i.e. $5\text{A} \times 1\text{ V/A} = 5\text{V}$). Note the exact value. If the second voltage is not exactly equal to the first voltage, adjust TP4 and repeat *both* measurements (5.0Ω and 2.5Ω) again. Repeat as required.

PROGRAMMING YOUR PULSE GENERATOR

KEY PROGRAMMING COMMANDS

The "OP1B Interface Programming Manual" describes in detail how to connect the pulse generator to your computer, and the programming commands themselves. A large number of commands are available; however, normally you will only need a few of these. Here is a basic sample sequence of commands that might be sent to the instrument after power-up, using the internal trigger source:

*rst	(resets the instrument)
trigger:source internal	(selects internal triggering)
frequency 10 Hz	(sets the frequency to 10 Hz)
pulse:width1 1 ms	(sets the channel 1 pulse width to 1 ms)
pulse:width2 3 ms	(sets the channel 1 pulse width to 3 ms)
pulse:delay 10 ms	(sets the inter-channel delay to 10 ms)
output on	(turns on the output for both channels)
source:current1 500 mA	(sets the channel 1 current amplitude to 0.5 amperes)
source:current2 5 A	(sets the channel 2 current amplitude to 5 amperes)
measure:amplitude1?	(this returns the current amplitude, in amperes, as measured by the monitor circuit on channel 1)
measure:amplitude2?	(this returns the current amplitude, in amperes, as measured by the monitor circuit on channel 2)

For triggering a single event, this sequence would be more appropriate:

*rst	(resets the instrument)
trigger:source hold	(turns off all triggering)
pulse:width1 1 ms	(sets the channel 1 pulse width to 1 ms)
pulse:width2 3 ms	(sets the channel 1 pulse width to 3 ms)
pulse:delay 10 ms	(sets the inter-channel delay to 10 ms)
output on	(turns on the output for both channels)
source:current1 500 mA	(sets the channel 1 current amplitude to 0.5 amperes)
source:current2 5 A	(sets the channel 2 current amplitude to 5 amperes)
trigger:source immediate	(generates a single non-repetitive trigger event)
trigger:source hold	(turns off all triggering)
output off	(turns off both outputs)

These commands will satisfy 90% of your programming needs.

ALL PROGRAMMING COMMANDS

For more advanced programmers, a complete list of the available commands is given below. These commands are described in detail in the "OP1B Interface Programming Manual". (Note: this manual also includes some commands that are not implemented in this instrument. They can be ignored.)

Note that the pulse width, amplitude, and monitor-related commands should be suffixed with the channel number, as illustrated in the previous section. If the suffix is not included, channel 1 will be assumed. The remaining commands will generate an error if a channel suffix is attached, since their effects are common to both channels.

<u>Keyword</u>	<u>Parameter</u>	<u>Notes</u>
LOCAL		
MEASure:		
:AMPLitude?		[query only]
OUTPut:		
:[STATe]	<boolean value>	
:PROTection		
:TRIPped?		[query only]
REMOTE		
[SOURce]:		
:FREQuency		
[:CW FIXed]	<numeric value>	
[SOURce]:		
:CURRent		
[:LEVel]		
[:IMMEDIATE]		
[:AMPLitude]	<numeric value> EXTernal	
:PROTection		
:TRIPped?		[query only]
[SOURce]:		
:PULSe		
:PERiod	<numeric value>	
:WIDTh	<numeric value>	
:DCYCLe	<numeric value>	
:HOLD	WIDTh DCYCLe	
:DELay	<numeric value>	
:GATE		
:LEVel	High Low	
STATUS:		
:OPERation		
:[EVENT]?		[query only, always returns "0"]
:CONDition?		[query only, always returns "0"]
:ENABle	<numeric value>	[implemented but not useful]
:QUESTionable		
:[EVENT]?		[query only, always returns "0"]
:CONDition?		[query only, always returns "0"]
:ENABle	<numeric value>	[implemented but not useful]
SYSTEM:		
:COMMunicate		
:GPIB		
:ADDRess	<numeric value>	
:SERial		
:CONTRol		
:RTS	ON IBFull RFR	
:[RECeive]		
:BAUD	1200 2400 4800 9600	
:BITS	7 8	
:ECHO	<boolean value>	
:PARity		
:[TYPE]	EVEN ODD NONE	

	:SBITS	1 2	
	:ERRor		
	:[NEXT]?		[query only]
	:COUNT?		[query only]
	:VERSion?		[query only]
	TRIGger:		
	:SOURce	INTernal EXTernal MANual HOLD IMMEDIATE	[no query form]
	*CLS		[no query form]
	*ESE	<numeric value>	
	*ESR?		[query only]
	*IDN?		[query only]
	*OPC		
	*SAV	0 1 2 3	[no query form]
	*RCL	0 1 2 3	[no query form]
	*RST		[no query form]
	*SRE	<numeric value>	
	*STB?		[query only]
	*TST?		[query only]
	*WAI		[no query form]

PERFORMANCE CHECK SHEET

8408



AVTECH ELECTROSYSTEMS LTD.

NANOSECOND WAVEFORM ELECTRONICS
SINCE 1975

P.O. BOX 265
OGDENSBURG, NY
U.S.A. 13669-0265
TEL: (315) 472-5270
FAX: (613) 226-2802

TEL: 1-800-265-6681
FAX: 1-800-561-1970

e-mail: info@avtechpulse.com
<http://www.avtechpulse.com>

X
P.O. BOX 5120 STN. F
OTTAWA, ONTARIO
CANADA K2C 3H4
TEL: (613) 226-5772
FAX: (613) 226-2802

December 3, 1997.

Bob Johnson
ISI Inc.
9138 Randolph Road, NE
Moses Lake, WA 98837

Dear Bob:

Following our telephone conversation of December 2nd, I am pleased to provide the following price and delivery quotation:

Quote No:	8408.
Model designation:	AV-156A-C-P-OP1B-ISIA.
No of output channels:	Two.
GPIB control:	OP1B option. See enclosed description.
Output amplitude:	0 to 5 Amps. Two independent controls.
Output pulse width:	1 to 100 ms. Two independent controls.
Channel A - Channel B delay:	0 to 100 ms. One control.
Load voltage range:	0 to +25 Volts.
Output current regulation:	≤ 2% for load voltage change from +25 to 0 Volts.
Repetition frequency:	Internal trigger: 1 Hz to 100 Hz. GPIB bus will also provide single pulse operation.
	External trigger: 0 to 100 Hz TTL.

	Manual trigger:	Manual push button for single pulse operation.
Rise, fall time:	≤ 10 us.	
Maximum duty cycle:	10 %.	
Monitor output:	Output amplitude is displayed on the LCD. Also provides a voltage output pulse which is a replica of the output current pulse.	
GPIB control:	The -OP1B GPIB function is described on the enclosed sheet.	
Dimensions: (H x W x D)	100 mm x 430 mm x 375 mm (3.9" x 17" x 14.8").	
Face plate:	See attached photo.	
Chassis material:	Aluminum. Anodized aluminum front panel with cast aluminum side panels (with gray plastic trim) and aluminum top and bottom panels with gray plastic trim.	
Connectors:	BNC.	
Rack mounting:	Includes -R5 rack mount kit for 19" rack mounting.	
Prime power:	120/240V, 50-60 Hz.	
Price:	\$5,998.00 US each, FOB destination.	
Delivery:	60 days ARO.	

Thank you for your continuing interest in our products. Please call me again (1-800-265-6681) if you require any additional information or modifications to the above quotation.

Yours truly,



Dr. Walter Chudobiak
Chief Engineer

WC:my
Encl.

February 27 198

Michael did this set in ward

Obsolete

Free for 8360 only