

AVTECH ELECTROSYSTEMS LTD.

NANOSECOND WAVEFORM ELECTRONICS
ENGINEERING . MANUFACTURING

P.O. BOX 265
OGDENSBURG
NEW YORK
13669
(315) 472-5270

BOX 5611 STN. "F"
OTTAWA, ONTARIO
CANADA K2C 3M1
(613) 226-5772
TELEX 053-4591

DETAILED TEST PROCEDURE FOR AVB

- 1) Adjust output of lab pulse generator to be used as trigger source to values shown below. Trigger scope externally and adjust delay on lab pulse generator to obtain stable display. Note relative position of leading edge of pulse.

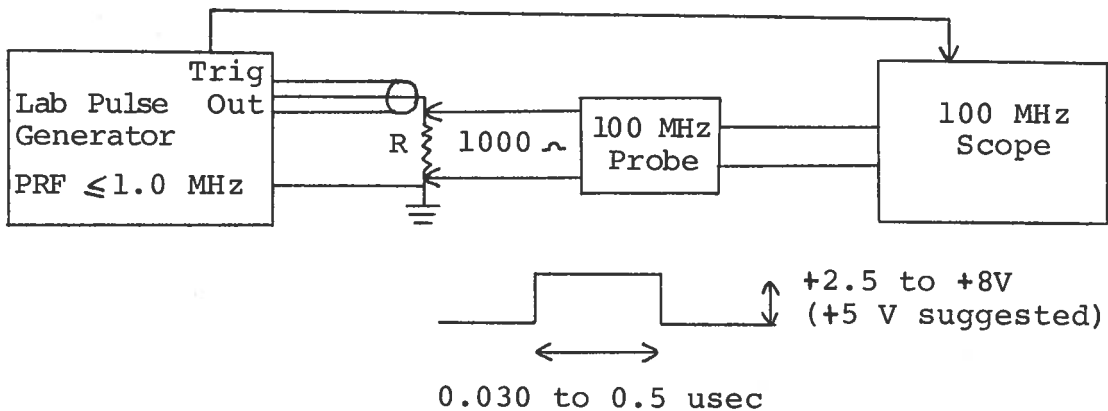

- 2) Remove 1000 Ω load and connect AVB to lab pulse generator output. Connect 50 Ω load to output of AVB and place high impedance 100 MHz scope probe across 50 Ω load. Apply +15V bias to AVB. Output monocycle should appear on scope about 35 nsec after the leading edge of the input trigger. If necessary, adjust delay control on lab pulse generator but do not adjust output amplitude.
- 3) Note that if input trigger amplitude (to 1000 Ω) does not fall within the bounds described above, the unit will not trigger.

4) The AVB unit and the other Avtech unit which you have compare as follows:

	AVB	OTHERS
Propagation delay	35 nsec	≤ 0.5 nsec
Min. input PW	30 nsec	≤ 1.0 nsec
Input trigger amplitude (to 1000 \sim)	+2.5 to 8.0 volts	+4.0 to +20 volts

FREQUENCY CONTROL CURVE

AVTECH ELECTROSYSTEMS LTD MODEL AV.
MONOCYCLE GENERATOR, SERIAL No.

Cable of length L (measured between extreme tips of connectors) connected between ports A and B.

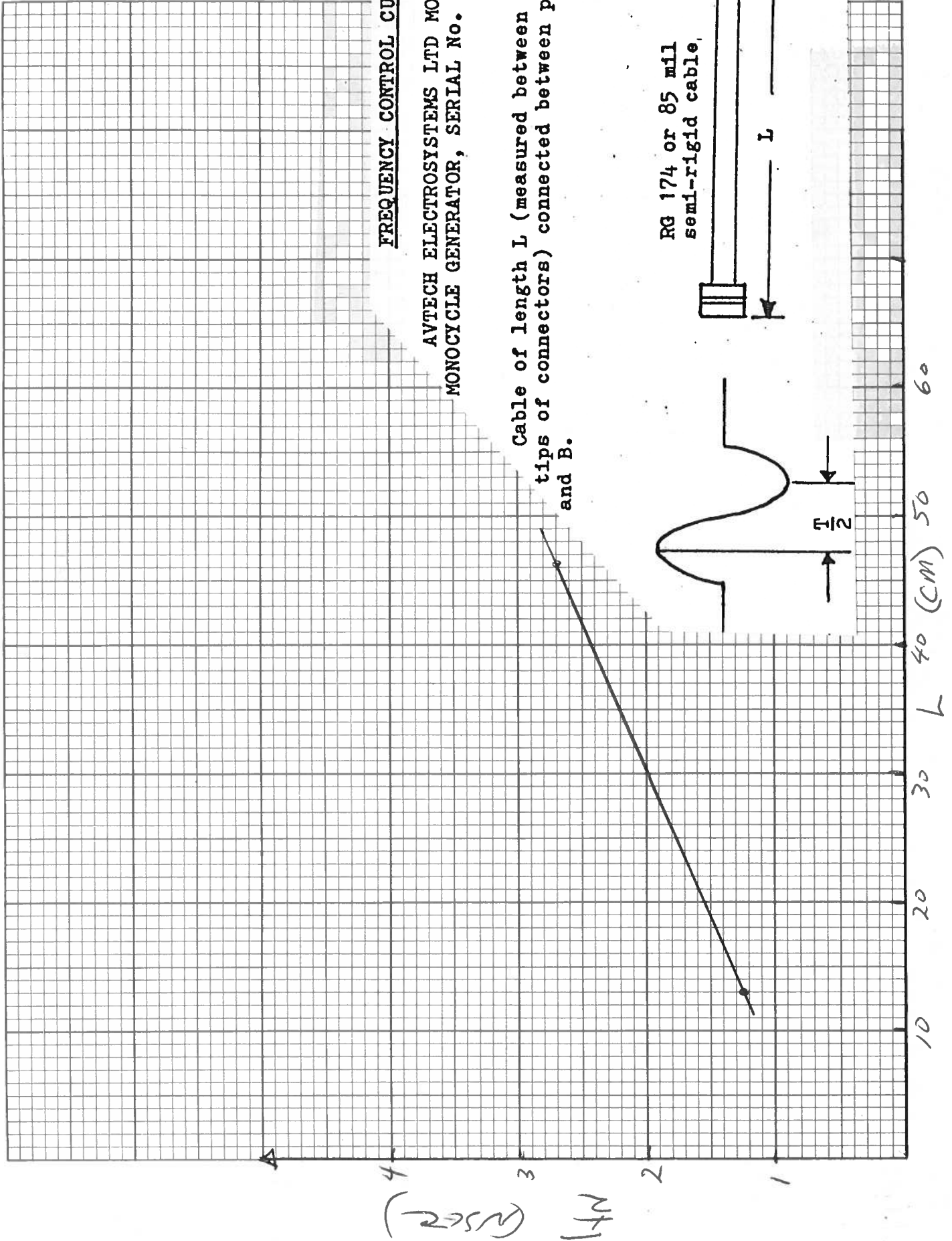

RG 174 or 85 mil
semi-rigid cable.

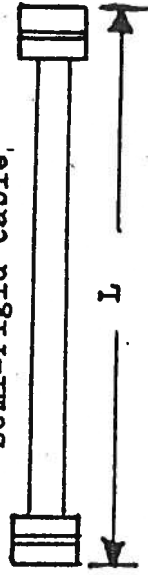

E/2

10 20 30 40 50 60
L (CM)