



AVTECH ELECTROSYSTEMS LTD.

NANOSECOND WAVEFORM ELECTRONICS
SINCE 1975

P.O. BOX 265
OGDENSBURG, NY
U.S.A. 13669-0265
TEL: (315) 472-5270
FAX: (613) 226-2802

TEL: 1-800-265-6681
FAX: 1-800-561-1970

e-mail: info@avtechpulse.com
<http://www.avtechpulse.com>

P.O. BOX 5120 STN. F
OTTAWA, ONTARIO
CANADA K2C 3H4
TEL: (613) 226-5772
FAX: (613) 226-2802

INSTRUCTIONS

MODEL AVB2-C PULSE GENERATOR

S.N.:

WARRANTY

Avtech Electrosystems Ltd. warrants products of its manufacture to be free from defects in material and workmanship under conditions of normal use. If, within one year after delivery to the original owner, and after prepaid return by the original owner, this Avtech product is found to be defective, Avtech shall at its option repair or replace said defective item. This warranty does not apply to units which have been disassembled, modified or subjected to conditions exceeding the applicable specifications or ratings. This warranty is the extent of the obligation assumed by Avtech with respect to this product and no other warranty or guarantee is either expressed or implied.

TECHNICAL SUPPORT

Phone: 613-226-5772 or 1-800-265-6681

Fax: 613-226-2802 or 1-800-561-1970

E-mail: info@avtechpulse.com

World Wide Web: <http://www.avtechpulse.com>

TABLE OF CONTENTS

| | |
|---|----|
| WARRANTY..... | 2 |
| TABLE OF CONTENTS..... | 3 |
| FIG. 1: PULSE GENERATOR TEST ARRANGEMENT..... | 4 |
| GENERAL OPERATING INSTRUCTIONS..... | 5 |
| FIG. 2: FRONT PANEL CONTROLS..... | 7 |
| FRONT PANEL CONTROLS..... | 8 |
| FIG. 3: BACK PANEL CONTROLS..... | 9 |
| BACK PANEL CONTROLS..... | 10 |
| FIG. 4: SYSTEM BLOCK DIAGRAM..... | 11 |
| SYSTEM DESCRIPTION AND REPAIR PROCEDURE..... | 12 |
| POWER SUPPLY AND FUSE REPLACEMENT..... | 13 |
| PERFORMANCE CHECK SHEET..... | 15 |

FIG. 1: PULSE GENERATOR TEST ARRANGEMENT

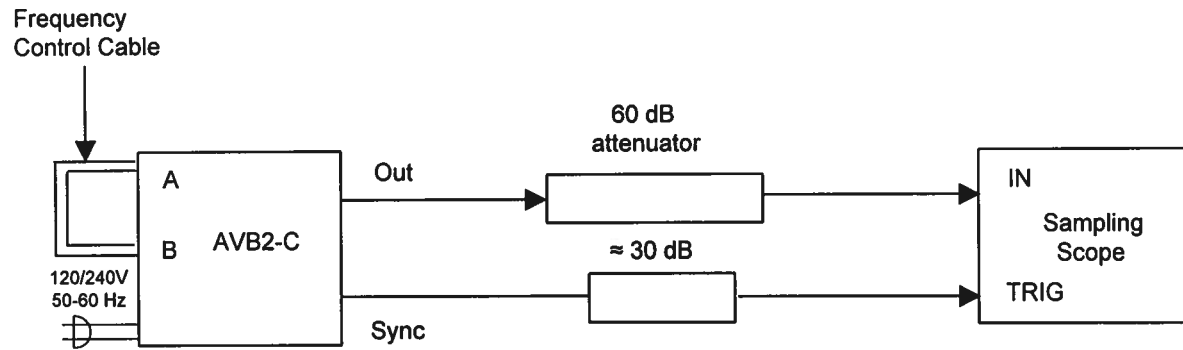

GENERAL OPERATING INSTRUCTIONS

- 1) The bandwidth capability of components and instruments used to display the pulse generator output signal (attenuators, cables, connectors, etc.) should exceed one gigahertz.
- 2) The use of 60 dB attenuator at the sampling scope vertical input channel will insure a peak input signal to the sampling scope of less than one Volt.
- 3) The sync output channel provides TTL level signals. To avoid overdriving the TRIG input channel of some sampling scopes, a 30 dB attenuator should be placed at the input to the sampling scope trigger channel.
- 4) To obtain a stable output display the PRF control on the front panel should be set mid-range while the PRF range switch may be in either range. The front panel TRIG toggle switch should be in the INT position. The front panel DELAY controls and the scope triggering controls are then adjusted to obtain a stable output. The scope may then be used to set the desired PRF by rotating the PRF control and by means of the PRF range switch.
- 5) The frequency control cable may be fabricated from RG174 miniature coax or from 85 mil semi-rigid cable. Increasing the cable length increases the "pulse width" or period of the output waveform as follows:

| L | PW |
|-----|--------|
| 48" | 10 ns |
| 36" | 8.5 ns |
| 18" | 6 ns |

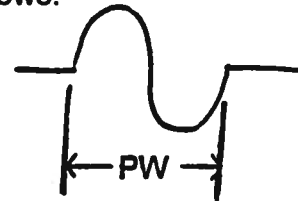

The rear panel L-H two-position switch should normally be in the "H" position. However, for operation at wide pulse widths (eg. 10 ns, 100 MHz) it may be necessary to set the switch in the "L" position in order to attain the full 10 ns.

- 6) The output pulse amplitude is controlled by means of the one turn potentiometer (AMP) and the HIGH-LOW switch adjacent to the AMP control. With the switch in the HIGH position, the output amplitude is variable over the range of 75 to 300 Volts while in the LOW position the output amplitude is variable over the range of about 0 to 250 Volts.
- 7) MONITOR Output. The back panel monitor output provides an attenuated replica (20 dB down) of the output. The monitor output is designed to operate into a 50 Ohm load. (option).

- 8) The unit can be converted from 120 to 240V 50-60Hz operation by adjusting the voltage selector card in the rear panel fused voltage selector-cable connector assembly.
- 9) For additional assistance:
Tel: (613) 226-5772
Fax: (613) 226-2802
Email: info@avtechpulse.com

FIG. 2: FRONT PANEL CONTROLS

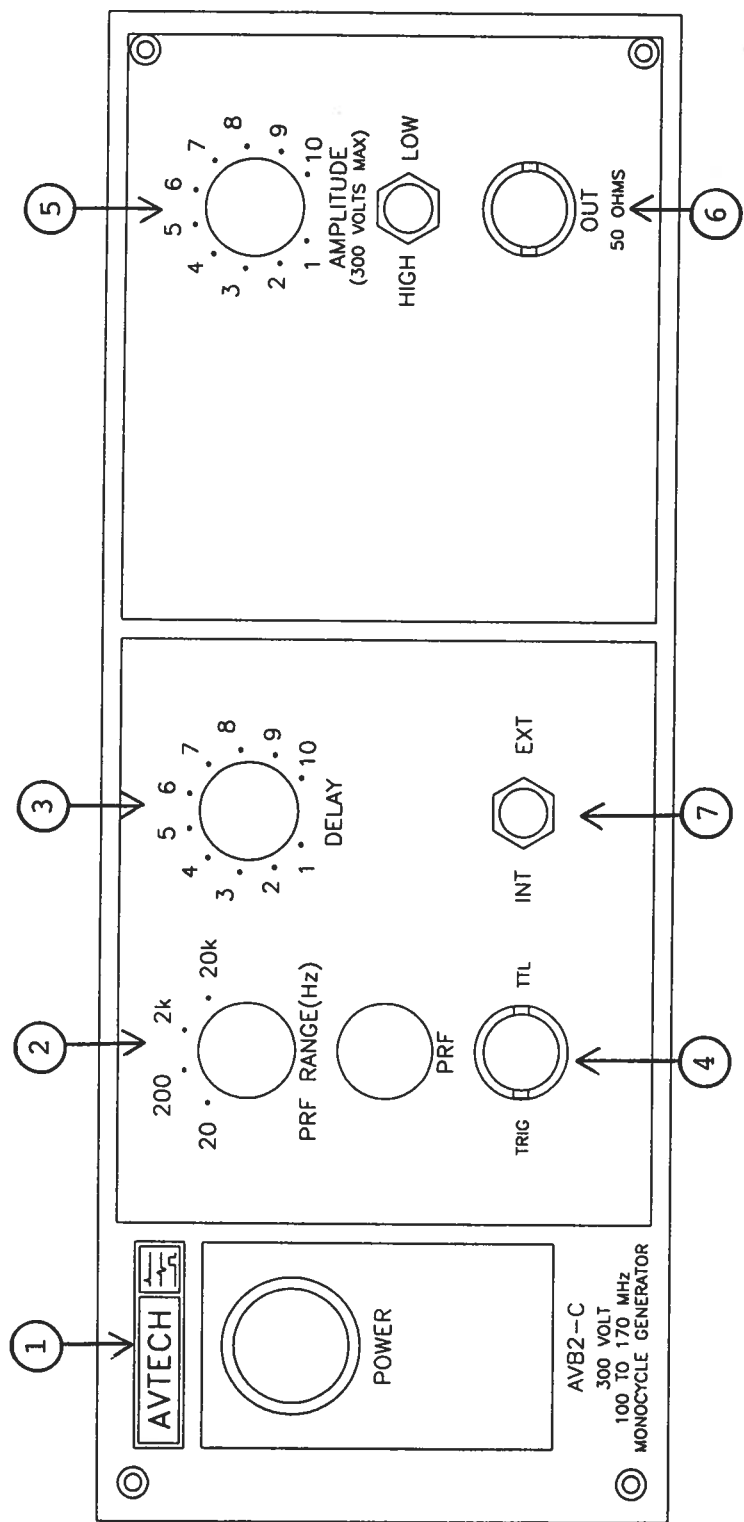

FRONT PANEL CONTROLS

- (1) ON-OFF Switch. Applies basic prime power to all stages.
- (2) PRF Control. The PRF RANGE and PRF controls determine output PRF as follows:
- | | | |
|---------|--------|--------|
| Range 1 | 2 Hz | 20 Hz |
| Range 2 | 20 Hz | 200 Hz |
| Range 3 | 200 Hz | 2 KHZ |
| Range 4 | 2 KHz | 20 KHz |
- (3) DELAY Control. Controls the relative delay between the reference output pulse provided at the TRIG output (4) the main output (6). This delay is variable over the range of 0 to at least 500 ns.
- (4) TRIG Output. This output precedes the main output (6) and is used to trigger the sampling scope time base. The output is a TTL level 100 ns (approx) pulse capable of driving a fifty Ohm load. The external trigger signal is applied at this input when the EXT-INT toggle switch is in the EXT position.
- (5) AMP Control. The output pulse amplitude is controlled by means of the one turn potentiometer (AMP) and the HIGH-LOW switch adjacent to the AMP control. With the switch in the HIGH position, the output amplitude is variable over the range of 75 to 300 Volts while in the LOW position the output amplitude is variable over the range of about 0 to 250 Volts.
- (6) OUT. BNC connector applies output to 50 Ohm load.
- (7) EXT-INT Control. With this toggle switch in the INT position, the PRF of the AVB2 unit is controlled via an internal clock which in turn is controlled by the PRF controls. With the toggle switch in the EXT position, the AVB2 unit requires a 50 ns (or wider) TTL level pulse applied at the TRIG input in order to trigger the output stages. In addition, in this mode, the scope time base must be triggered by the external trigger source.

FIG. 3: BACK PANEL CONTROLS

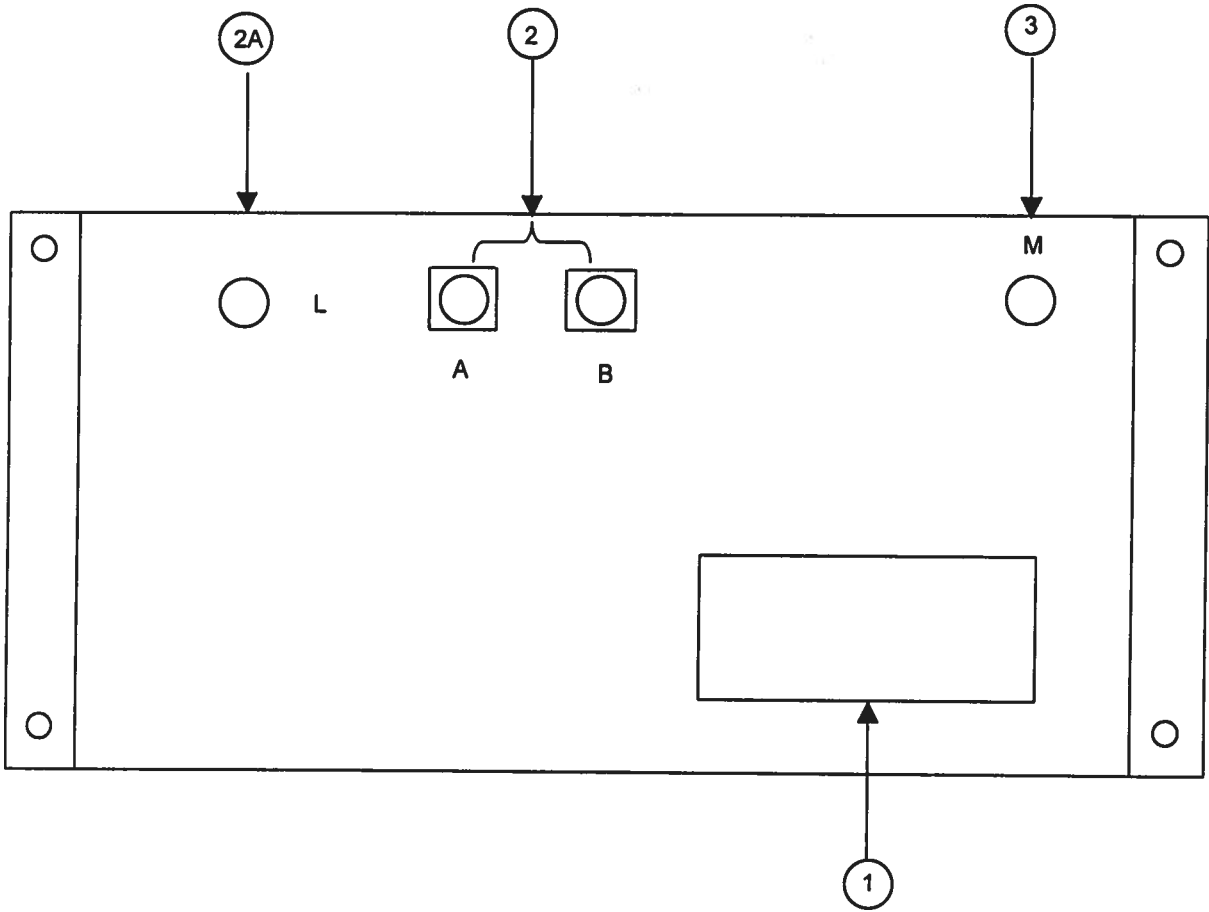

BACK PANEL CONTROLS

- (1) **FUSED CONNECTOR, VOLTAGE SELECTOR.** The detachable power cord is connected at this point. In addition, the removable cord is adjusted to select the desired input operating voltage. The unit also contains the main power fuse. (0.5 A SB)
- (2) **FREQUENCY CONTROL CABLE.** The frequency control cable may be fabricated from RG174 miniature coax or from 85 mil semi-rigid cable. Increasing the cable length increases the "pulse width" or period of the output waveform as follows:

| L | PW |
|-----|--------|
| 48" | 10 ns |
| 36" | 8.5 ns |
| 18" | 6 ns |

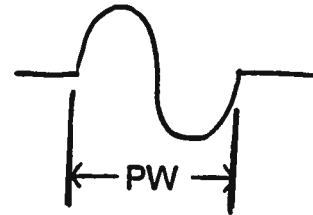

- (2a) **LH.** The L-H two-position switch should normally be in the "H" position. However, for operation at wide pulse widths (eg. 10 ns, 100 MHz) it may be necessary to set the switch in the "L" position in order to attain the full 10 ns.
- (3) **MONITOR Output.** The monitor output provides an attenuated replica (20 dB down) of the output. The monitor output is designed to operate into a 50 Ohm load. (option).

FIG. 4: SYSTEM BLOCK DIAGRAM

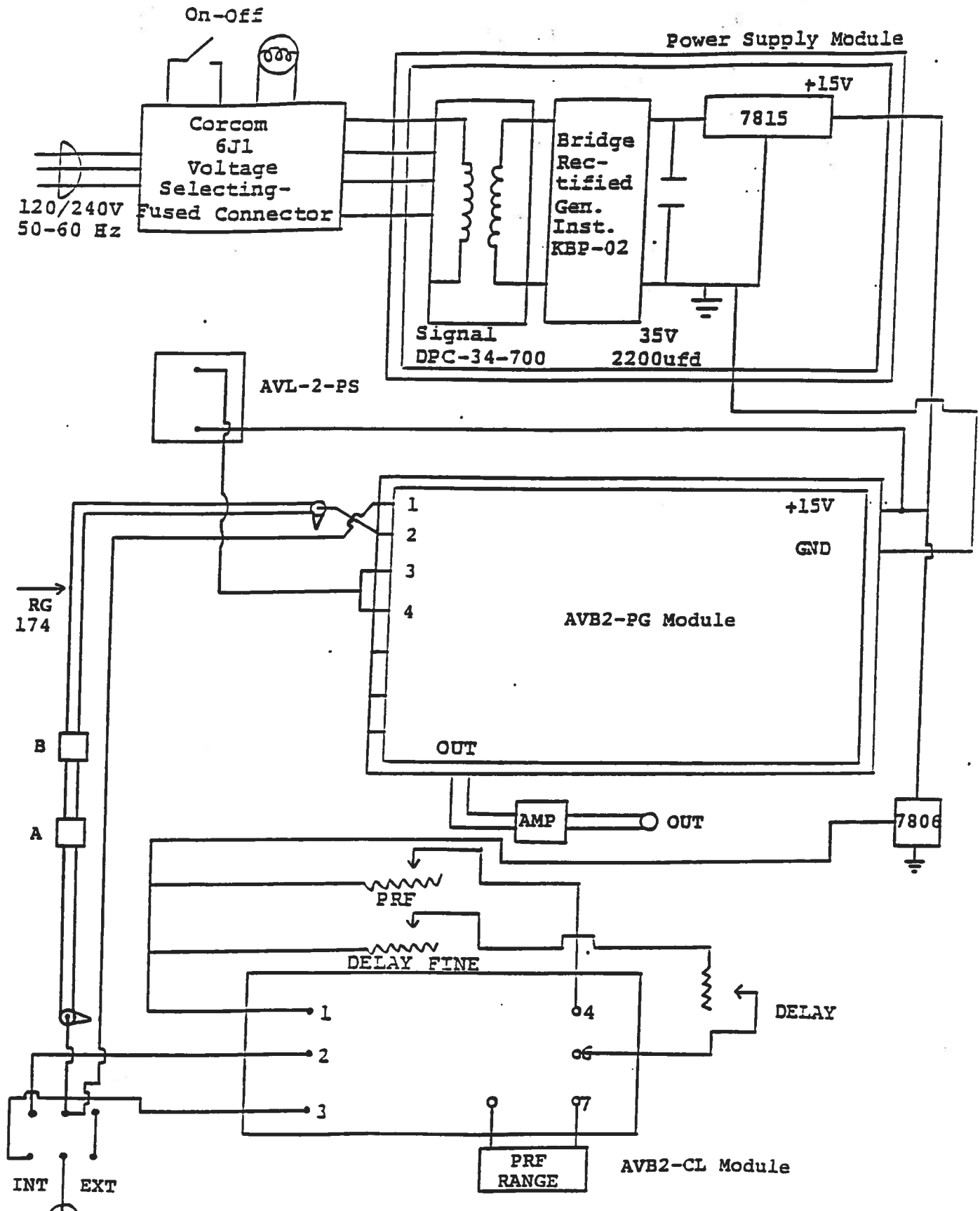

SYSTEM DESCRIPTION AND REPAIR PROCEDURE

The AVB2-C consists of a pulse generator module (AVB2-PG), a power combiner module (AVB2-CPL-1T) and a clock module and a power supply board which supplies +15 Volts (600 mA max) to the pulse generator module. In the event that the unit malfunctions, remove the instrument cover by removing the four Phillips screws on the back panel of the unit. The top cover may then be slid off. Measure the voltage at the +15 V pin of the PG module. If this voltage is substantially less than +15 Volts, unsolder the line connecting the power supply and PG modules and connect 100 Ohm 10 W load to the PS output. The voltage across this load should be about +15V DC. If this voltage is substantially less than 15 Volts the PS module is defective and should be repaired or replaced. If the voltage across the resistor is near 15 Volts, then the PG module should be replaced or repaired. The sealed PG module must be returned to Avtech for repair (or replacement). The clock module provides a 0.1 us TTL level trigger pulse at Pin 2 to trigger the PG module and a 0.1 us TTL level sync pulse at Pin 3 to trigger the sampling scope display device. The output at Pin 3 precedes the output at Pin 2 by almost 0 to 100 ns depending on the DELAY control setting. The clock module is powered by +5.8 V supplied by the 7806. With the INT-EXT switch in the EXT position, the clock module is disconnected from the PG module. The clock module is functioning properly if:

- a) 0.1 us TTL level outputs are observed at Pins 2 and 3.
- b) The PRF of the outputs can be varied over the range of 20 Hz to 20 kHz using the PRF and PRF RANGE controls.
- c) The relative delay between the Pin 2 and 3 outputs can be varied by at least 500 ns by the DELAY control.

The sealed clock module must be returned to Avtech for repair or replacement if the above conditions are not observed.

POWER SUPPLY AND FUSE REPLACEMENT

This instrument has three fuses (plus one spare). One, which protects the AC input, is located in the rear-panel power entry module, as described in the “Rear Panel Controls” section of this manual. If the power appears to have failed, check the AC fuse first.

The other two fuses (plus one spare) are located on the internal DC power supply, as shown below:

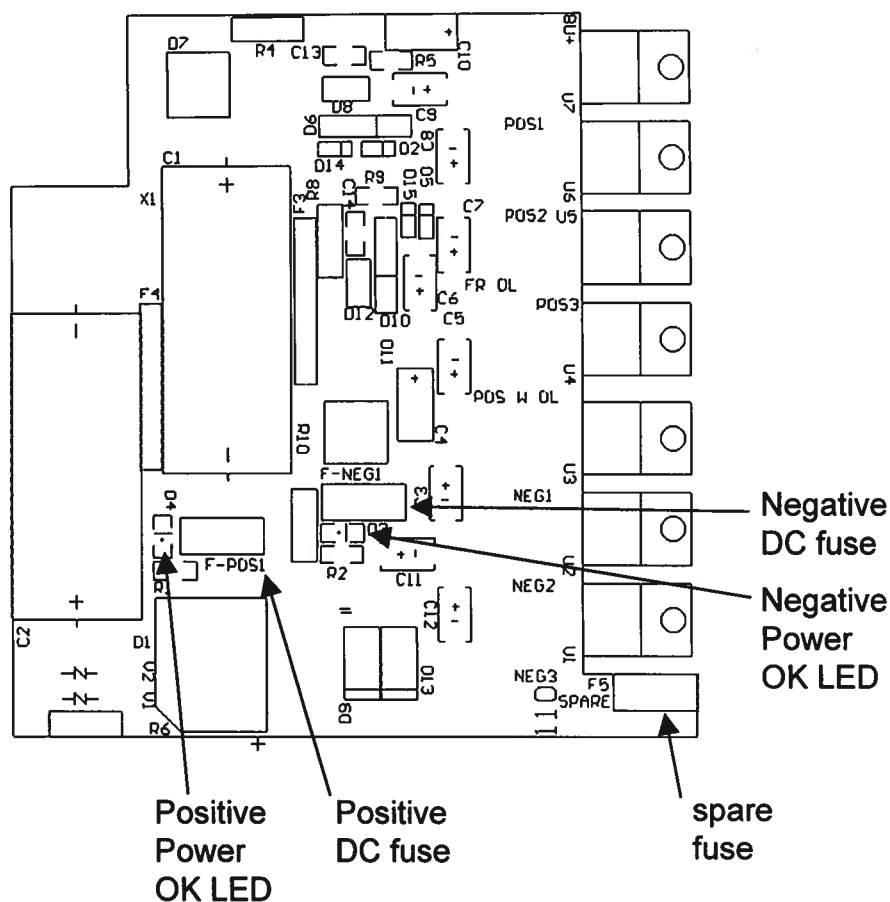

The spare fuse may be used to replace one of the other fuses, if required.

The three fuses on this circuit board are 0.5A slow-blow fuses, Littlefuse part number R452.500. (This fuse can be ordered from Digikey, www.digikey.com. The Digikey part number is F1341CT-ND).

If you suspect that the DC fuses are blown, follow this procedure:

1. Remove the top cover, by removing the four Phillips screws on the top cover and then sliding the cover back and off.
2. Locate the two "Power OK" LEDs on the power supply circuit board, as illustrated above.
3. Turn on the instrument.
4. Observe the "Power OK" LEDs. If the fuses are not blown, the two LEDs will be lit (bright red). If one of the LEDs is not lit, the fuse next to it has blown.
5. Turn off the instrument.
6. If a fuse is blown, use needle-nose pliers to remove the blown fuse from its surface-mount holder.
7. Replace the fuse.