

AVTECH ELECTROSYSTEMS LTD.

**NANOSECOND WAVEFORM ELECTRONICS
ENGINEERING . MANUFACTURING**

□ P.O. BOX 265
OGDENSBURG
NEW YORK
13669
(315) 472-5270

✠ BOX 5120 STN. "F"
OTTAWA, ONTARIO
CANADA K2C 3H4
(613) 226-5772
TELEX 053-4591

INSTRUCTIONS

MODEL AVD-M1-PS-D MONOCYCLE GENERATOR

S.N. :

WARRANTY

Avtech Electrosystems Ltd. warrants products of its manufacture to be free from defects in material and workmanship under conditions of normal use. If, within one year after delivery to the original owner, and after prepaid return by the original owner, this Avtech product is found to be defective, Avtech shall at its option repair or replace said defective item. This warranty does not apply to units which have been disassembled, modified or subjected to conditions exceeding the applicable specifications or ratings. This warranty is the extent of the obligation or liability assumed by Avtech with respect to this product and no other warranty or guarantee is either expressed or implied.

MONOCYCLE GENERATOR TEST ARRANGEMENT

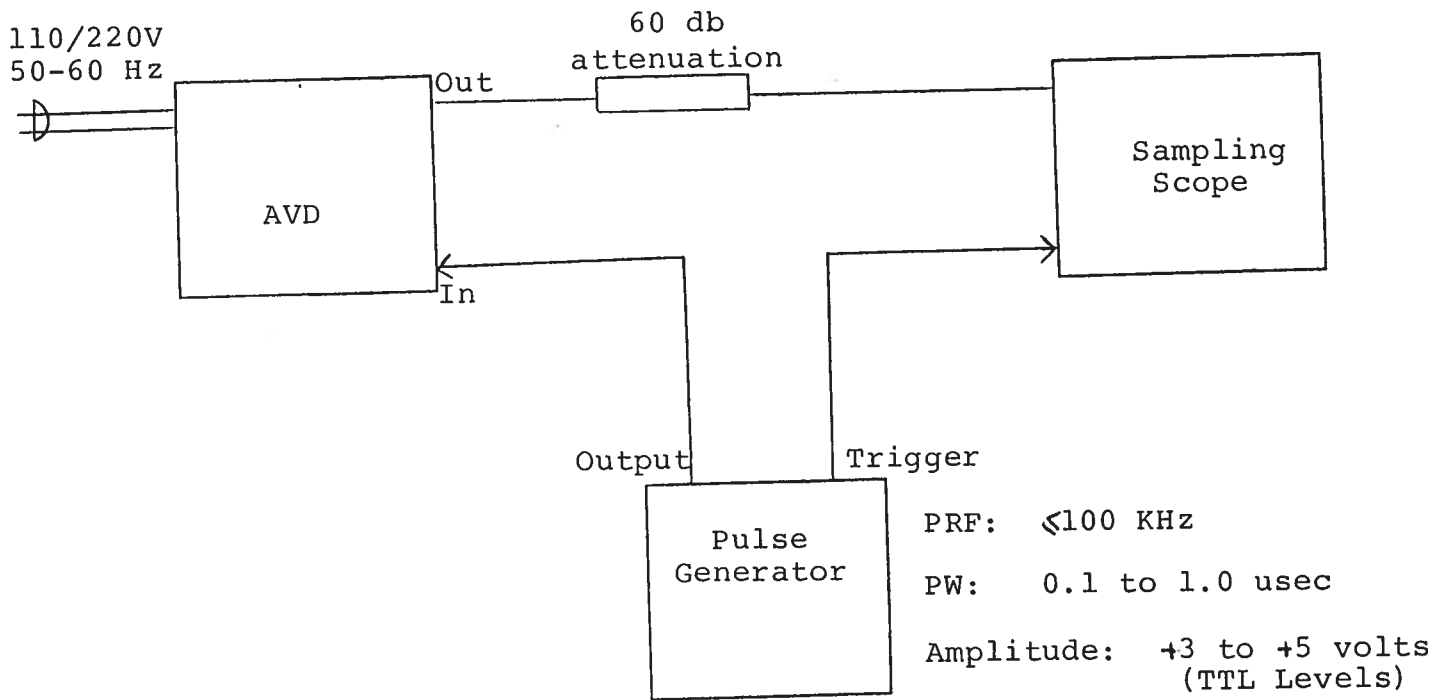

Notes:

- 1) The bandwidth capability of components and instruments used to display the impulse generator output signal (attenuators, cables, connectors, etc.) should exceed 1.0 gigahertz.
- 2) The use of 60 db attenuation will insure a peak input signal to the sampling scope of less than one volt.
- 3) In general, the pulse generator trigger delay control should be set in the 100 nsec range. Other settings should be as shown in the above diagram. The monocycle generator output is delayed with respect to the trigger input signal by about 70 nsec (typically).
- 4) The monocycle generator can withstand an infinite VSWR on the output port.
- 5) The relative propagation delay through the unit is variable from 0 to 10 nsec via the one turn DELAY control.

BACK PANEL CONTROLS

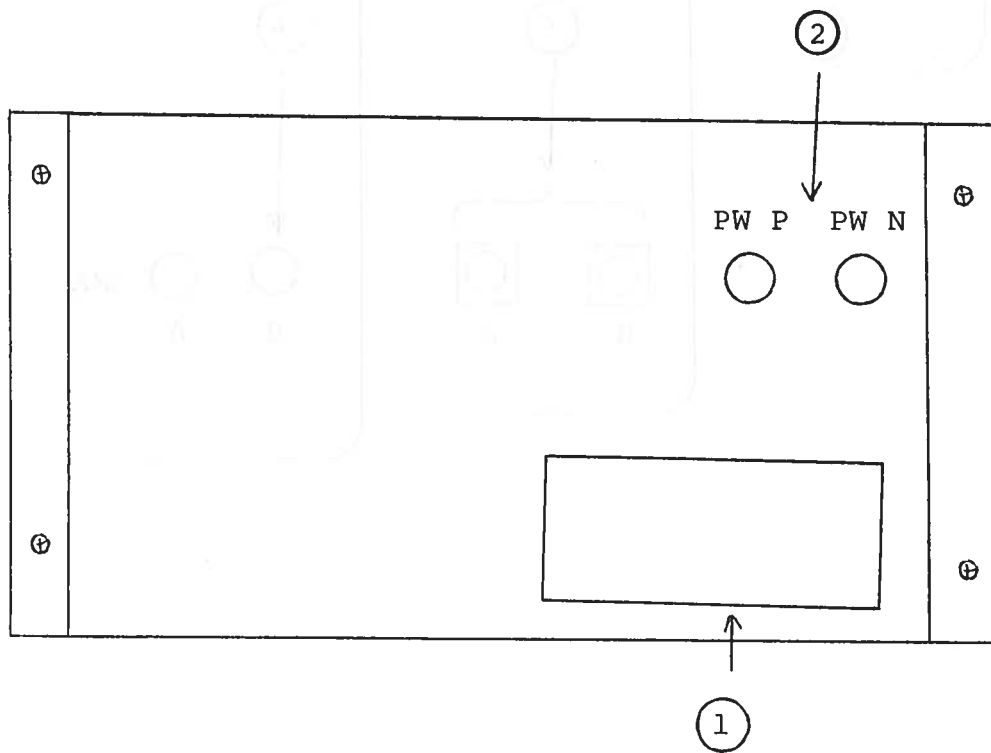

- (1) FUSED CONNECTOR, VOLTAGE SELECTOR. The detachable power cord is connected at this point. In addition, the removable cord is adjusted to select the desired input operating voltage. The unit also contains the main power fuse.

- (2) OUTPUT FREQUENCY FINE Control. The output frequency is slightly dependent on the setting of the PW P and PW N pot controls on the back panel. Clockwise rotation of the pot controls tends to increase the width of positive and negative going segments of the output sinusoid.

SYSTEM BLOCK DIAGRAM AND REPAIR PROCEDURE

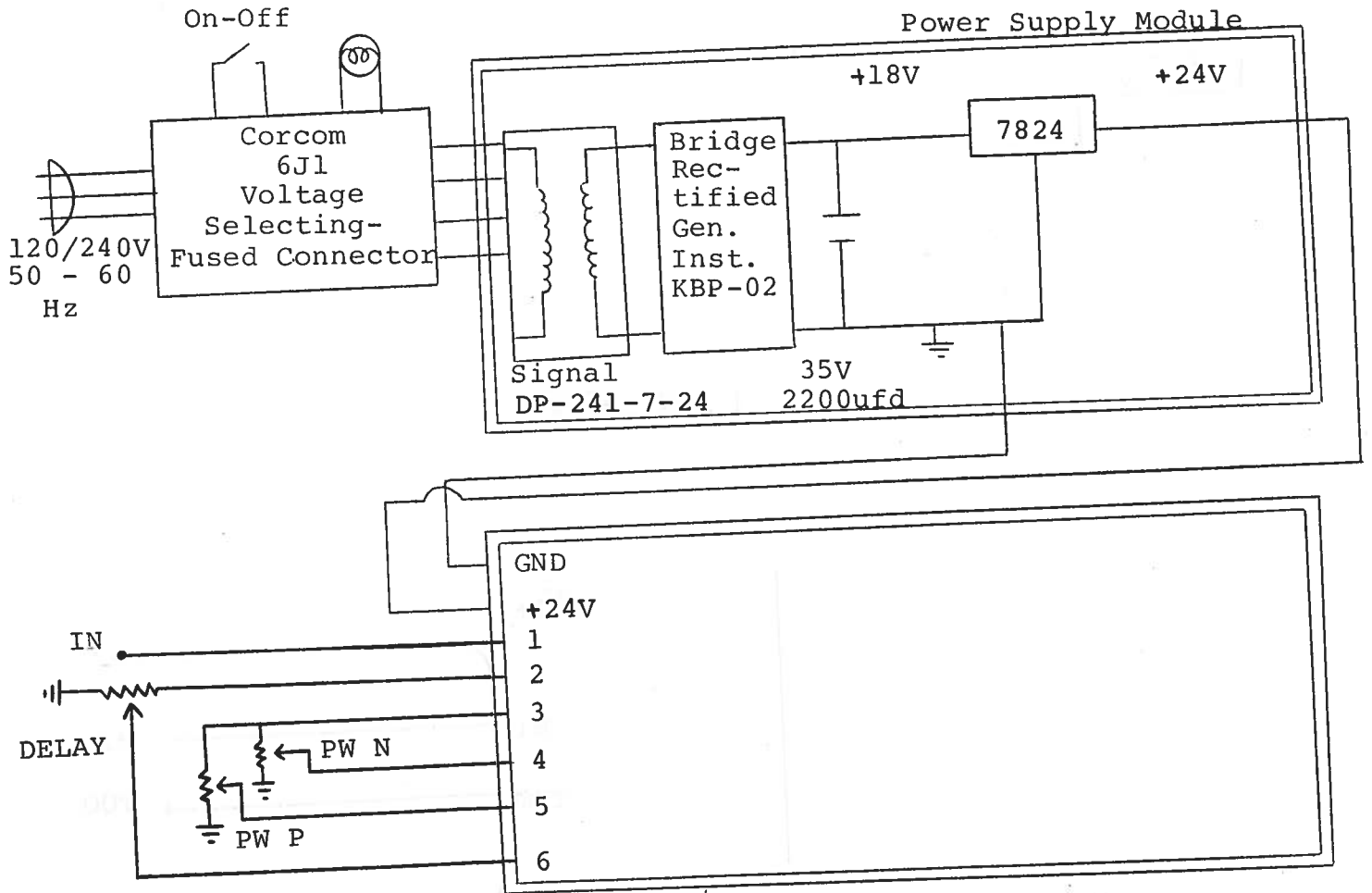

AVD-PG Module

SYSTEM DESCRIPTION AND REPAIR PROCEDURE

The AVD-PS consists of a pulse generator module (AVD-PG) and a power supply board which supplies +15 volts (600 mA max) to the pulse generator module. In the event that the AVD-PS unit malfunctions, remove the instrument cover by removing the four Phillips screws on the back panel. The top cover may then be slid off. Measure the voltage at the +15 V pin of the PG module. If this voltage is substantially less than +15 volts, unsolder the line connecting the PS and PG modules and connect 50 ohm 10 W load to the PS output. The voltage across this load should be about 15 V DC. If this voltage is substantially less than 15 volts the PS module is defective and should be repaired or replaced. If the voltage across the resistor is near 15 volts, then the PG module should be replaced or repaired. The sealed PG module must be returned to Avtech for repair (or replacement).

Schroff 04.10.86