



AVTECH ELECTROSYSTEMS LTD.

NANOSECOND WAVEFORM ELECTRONICS
SINCE 1975

P.O. BOX 265
OGDENSBURG, NY
U.S.A. 13669-0265
TEL: (315) 472-5270
FAX: (613) 226-2802

TEL: 1-800-265-6681
FAX: 1-800-561-1970

e-mail: info@avtechpulse.com
<http://www.avtechpulse.com>

P.O. BOX 5120 STN. F
OTTAWA, ONTARIO
CANADA K2C 3H4
TEL: (613) 226-5772
FAX: (613) 226-2802

INSTRUCTIONS

MODEL AVG-3A-COA1 IMPULSE GENERATOR

S.N. :

WARRANTY

Avtech Electrosystems Ltd. warrants products of its manufacture to be free from defects in material and workmanship under conditions of normal use. If, within one year after delivery to the original owner, and after prepaid return by the original owner, this Avtech product is found to be defective, Avtech shall at its option repair or replace said defective item. This warranty does not apply to units which have been disassembled, modified or subjected to conditions exceeding the applicable specifications or ratings. This warranty is the extent of the obligation assumed by Avtech with respect to this product and no other warranty or guarantee is either expressed or implied.

TECHNICAL SUPPORT

Phone: 613-226-5772 or 1-800-265-6681

Fax: 613-226-2802 or 1-800-561-1970

E-mail: info@avtechpulse.com

World Wide Web: <http://www.avtechpulse.com>

IMPULSE GENERATOR TEST ARRANGEMENT

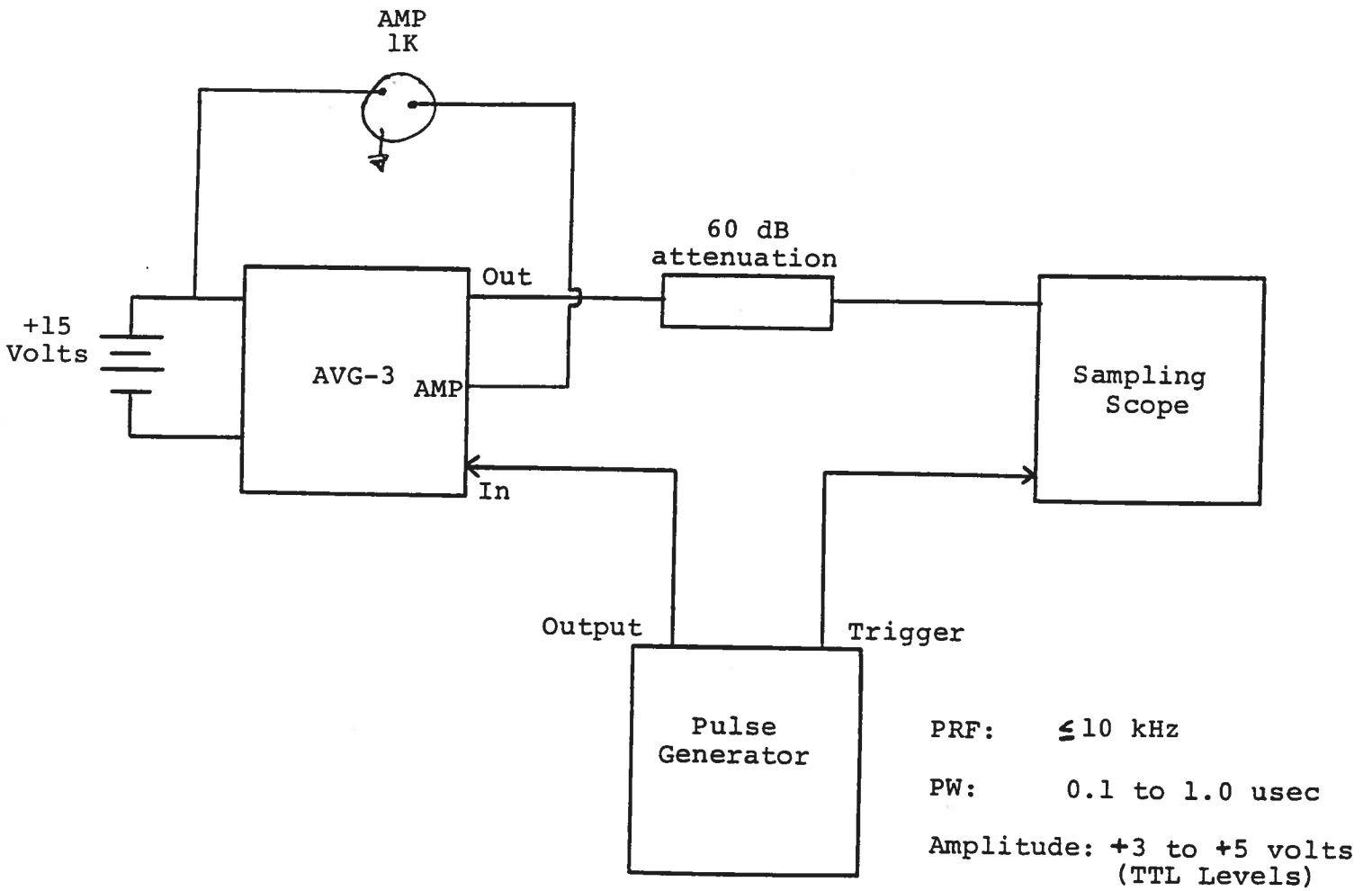

Notes:

- 1) The bandwidth capability of components and instruments used to display the impulse generator output signal (attenuators, cables, connectors, etc.) should exceed 1.0 gigahertz.
- 2) The module should be bolted to a heat sink capable of dissipating 7 Watts.
- 3) The use of 60 dB attenuation will insure a peak input signal to the sampling scope of less than one Volt.
- 4) In general, the pulse generator trigger delay control should be set in the 100 ns range. Other settings should be as shown in the above diagram. The impulse generator output is delayed with respect to the trigger input signal by about 70 ns. (typically).
- 5) The impulse generator can withstand an infinite VSWR on the output port.
- 6) The output amplitude may be varied from 150 to 500 Volts using a one turn 1K pot connected between the +15V supply and the front panel "AMP" solder terminal.
- 7) For additional assistance:

Tel: (613) 226-5772
Fax: (613) 226-2802



AVTECH ELECTROSYSTEMS LTD.

NANOSECOND WAVEFORM ELECTRONICS
SINCE 1975

P.O. BOX 265
OGDENSBURG, NY
U.S.A. 13669-0265
TEL: (315) 472-5270
FAX: (613) 226-2802

TEL: 1-800-265-6681
FAX: 1-800-561-1970
U.S.A. & CANADA

e-mail: info@avtechpulse.com

X BOX 5120 STN. F
OTTAWA, ONTARIO
CANADA K2C 3H4
TEL: (613) 226-5772
FAX: (613) 226-2802

Fax Ref No: 1032 From: Avtech Electrosystems Ltd.

To: Conoptics, Inc. Our Fax No: (613) 226-2802

Date: November 27, 1996

Attn: Ron Pizzo Receivers Fax No: 203-790-6145

Subject: AVG-3A-COA1 Quotation No. of pages: 2

Following our telephone conversation of November 26th, this will confirm that we can supply Model AVG-3A-COA1 as follows:

A) Model designation: AVG-3A-COA1.

Output amplitude: +150 to +450 Volts.

Output pulse width: 7 ns.

Rise time: 3 ns.

Fall time: 3 ns.

Package size: 1.7" x 2.6" x 4.3".

Prime power: +15 Volts 500 mA
(unit should be on a heat sink).

Price: \$1,795.00 US each,
FOB destination.

Delivery: 4 weeks ARO.



AVTECH ELECTROSYSTEMS. LTD.

NANOSECOND WAVEFORM ELECTRONICS
SINCE 1975

P.O. BOX 265
OGDENSBURG, NY
U.S.A. 13669-0265
TEL: (315) 472-5270
FAX: (613) 226-2802

TEL: 1-800-265-6681
FAX: 1-800-561-1970

e-mail: info@avtechpulse.com
<http://www.avtechpulse.com>

P.O. BOX 5120 STN. F
OTTAWA, ONTARIO
CANADA K2C 3H4
TEL: (613) 226-5772
FAX: (613) 226-2802

Fax Ref. No:	<u>3478</u>	From:	<u>Avtech Electrosystems Ltd.</u>
To:	<u>Conoptics</u>	Our Fax No:	<u>(613) 226-2802</u>
		Date:	<u>March 27, 1998</u>
Attn:	<u>Bob Enscoe</u>	Receivers Fax No:	<u>203-790-6145</u>
Phone:	<u>203-743-3349</u>	No. of pages:	<u>1</u>
Subject:	<u>AVG-3A-COA1, our quote 8606</u>	C.C.	<u></u>

Following our telephone conversation of March 27th, this will confirm that:

- a) The pulse width (at the 20% rise point) is 7 ns.
- b) The amplitude is electronically controlled (0 to +10 Volts) from +150 to +450 Volts.

Regards,

Dr. Walter Chudobiak
Chief Engineer

WC:pr

July 9/98

in WP

F:\WP\INSTR\AVG\3ACOR1.INS