



AVTECH ELECTROSYSTEMS LTD.

NANOSECOND WAVEFORM ELECTRONICS
SINCE 1975

□ P.O. BOX 265
OGDENSBURG, NY
U.S.A. 13669-0265
TEL: (315) 472-5270
FAX: (613) 226-2802

TEL: 1-800-265-6681
FAX: 1-800-561-1970

e-mail: info@avtechpulse.com
<http://www.avtechpulse.com>

□ P.O. BOX 5120 STN. F
OTTAWA, ONTARIO
CANADA K2C 3H4
TEL: (613) 226-5772
FAX: (613) 226-2802

INSTRUCTIONS

MODEL AVG-3B-C PULSE GENERATOR

S.N.:

WARRANTY

Avtech Electrosystems Ltd. warrants products of its manufacture to be free from defects in material and workmanship under conditions of normal use. If, within one year after delivery to the original owner, and after prepaid return by the original owner, this Avtech product is found to be defective, Avtech shall at its option repair or replace said defective item. This warranty does not apply to units which have been disassembled, modified or subjected to conditions exceeding the applicable specifications or ratings. This warranty is the extent of the obligation assumed by Avtech with respect to this product and no other warranty or guarantee is either expressed or implied.

TECHNICAL SUPPORT

Phone: 613-226-5772 or 1-800-265-6681

Fax: 613-226-2802 or 1-800-561-1970

E-mail: info@avtechpulse.com

World Wide Web: <http://www.avtechpulse.com>

TABLE OF CONTENTS

WARRANTY.....	2
TABLE OF CONTENTS	3
FIG. 1: PULSE GENERATOR TEST ARRANGEMENT.....	4
GENERAL OPERATING INSTRUCTIONS	5
FIG. 2: FRONT PANEL CONTROLS	6
FRONT PANEL CONTROLS	7
FIG. 3: BACK PANEL CONTROLS.....	8
BACK PANEL CONTROLS.....	9
POWER SUPPLY AND FUSE REPLACEMENT.....	10
PERFORMANCE CHECK SHEET	12

FIG. 1: PULSE GENERATOR TEST ARRANGEMENT

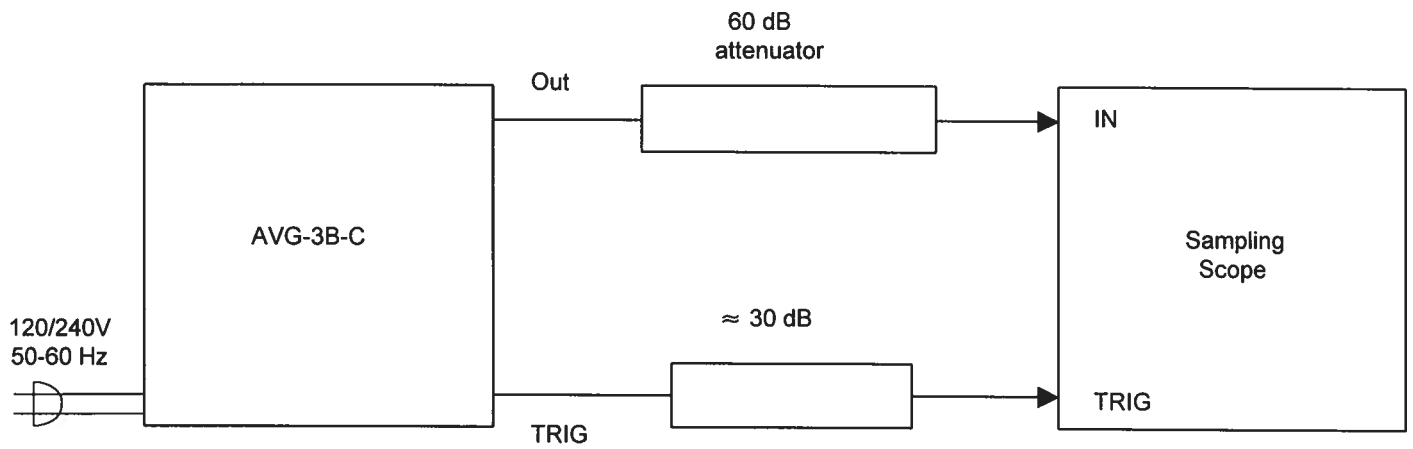

GENERAL OPERATING INSTRUCTIONS

- 1) The bandwidth capability of components and instruments used to display the pulse generator output signal (attenuators, cables, connectors, etc.) should exceed one gigahertz.
- 2) The use of 60 dB attenuator at the sampling scope vertical input channel will insure a peak input signal to the sampling scope of less than one Volt. It is critically important that the peak voltage rating of the attenuator must exceed 450 Volts.
- 3) The TRIG output channel provides TTL level signals. To avoid overdriving the TRIG input channel of some sampling scopes, a 30 dB attenuator should be placed at the input to the sampling scope trigger channel.
- 4) To obtain a stable output display the PRF control on the front panel should be set mid-range while the PRF range switch may be in either range. The front panel TRIG toggle switch should be in the INT position. The front panel DELAY controls and the scope triggering controls are then adjusted to obtain a stable output.
- 5) The output pulse amplitude is controlled by means of the one turn potentiometer (AMP). For units with the -EA option, the output amplitude may be voltage controlled by setting the rear panel AMP switch in the EXT position and then applying 0 to +10 VDC to the "A" BNC connector ($R_{IN} \geq 10K$).
- 6) The unit may be triggered externally by placing the INT-EXT switch in the EXT position and applying a TTL level pulse ($PW > 50$ ns) to the TRIG connector.
- 7) The monitor output (-M) provides a 20 dB attenuated coincident replica of the main output to 50 Ohms. (option).
- 8) The unit can be converted from 120 to 240V 50-60 Hz operation by adjusting the voltage selector card in the rear panel fused voltage selector-cable connector assembly.
- 9) For additional assistance:

Tel: (613)226-5772
Fax: (613)226-2802
Email: info@avtechpulse.com

FIG. 2: FRONT PANEL CONTROLS

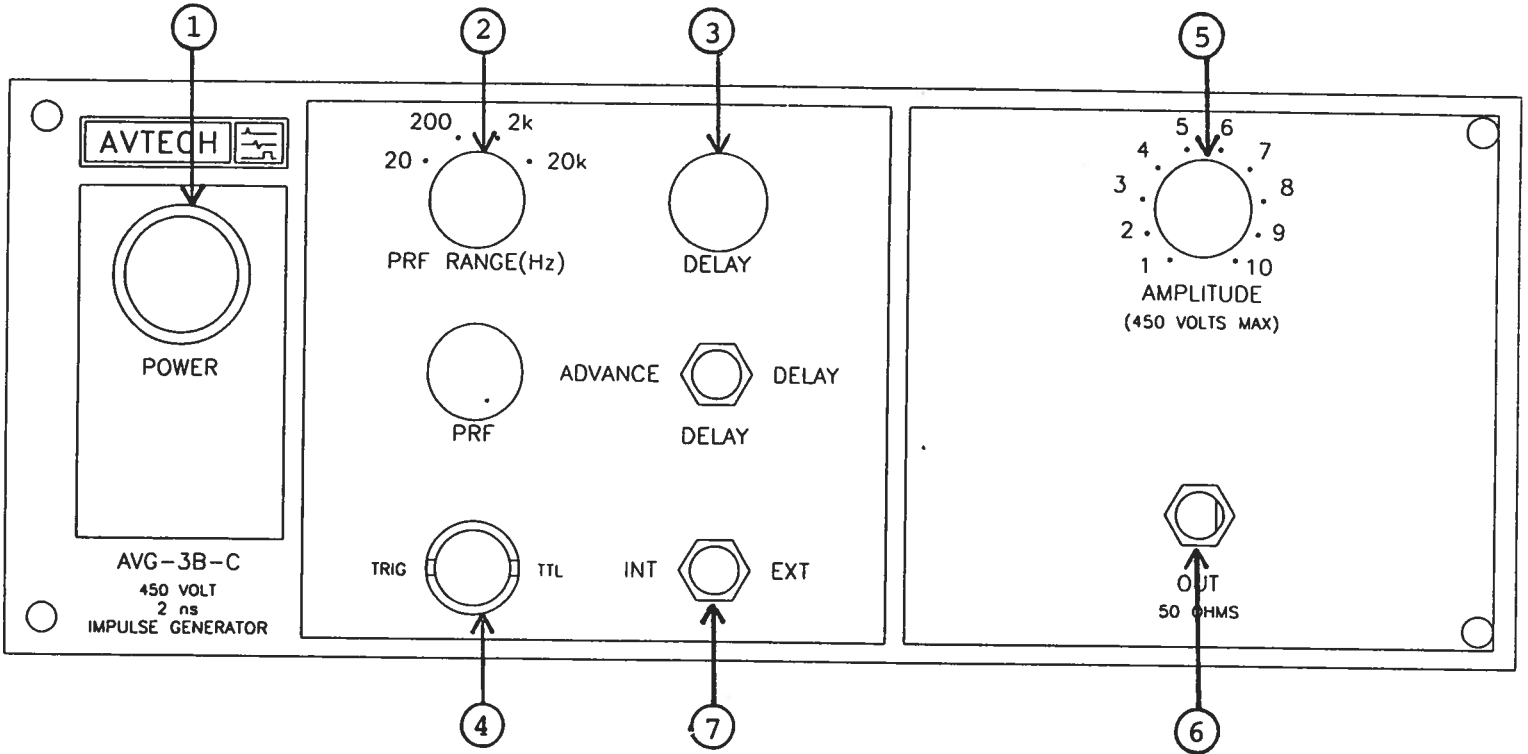

FRONT PANEL CONTROLS

- 1) ON-OFF Switch. Applies basic prime power to all stages.
- 2) PRF Control. The PRF RANGE and PRF controls determine output PRF as follows:

PRF MIN	PRF MAX
2 Hz	20 Hz
20 Hz	200 Hz
200 Hz	2 kHz
2 kHz	20 kHz

- 3) DELAY Control. Controls the relative delay between the reference output pulse provided at the TRIG output (4) and the main output (6). This delay is variable over the range of 0 to about 100 ns.
- 4) TRIG Output. The output is a TTL level 100 ns (approx) pulse capable of driving a fifty Ohm load. The external trigger signal is applied at this input when the EXT-INT toggle switch is in the EXT position.
- 5) AMP Control. The output pulse amplitude is controlled by means of the one turn potentiometer.
- 6) OUT. SMA connector applies output to 50 Ohm load.
- 7) EXT-INT Control. With this toggle switch in the INT position, the PRF of the AVG unit is controlled via an internal clock which in turn is controlled by the PRF controls. With the toggle switch in the EXT position, the AVG unit requires a TTL level pulse (PW > 50 ns) applied at the TRIG input in order to trigger the output stages. In addition, in this mode, the scope time base must be triggered by the external trigger source.

FIG. 3: BACK PANEL CONTROLS

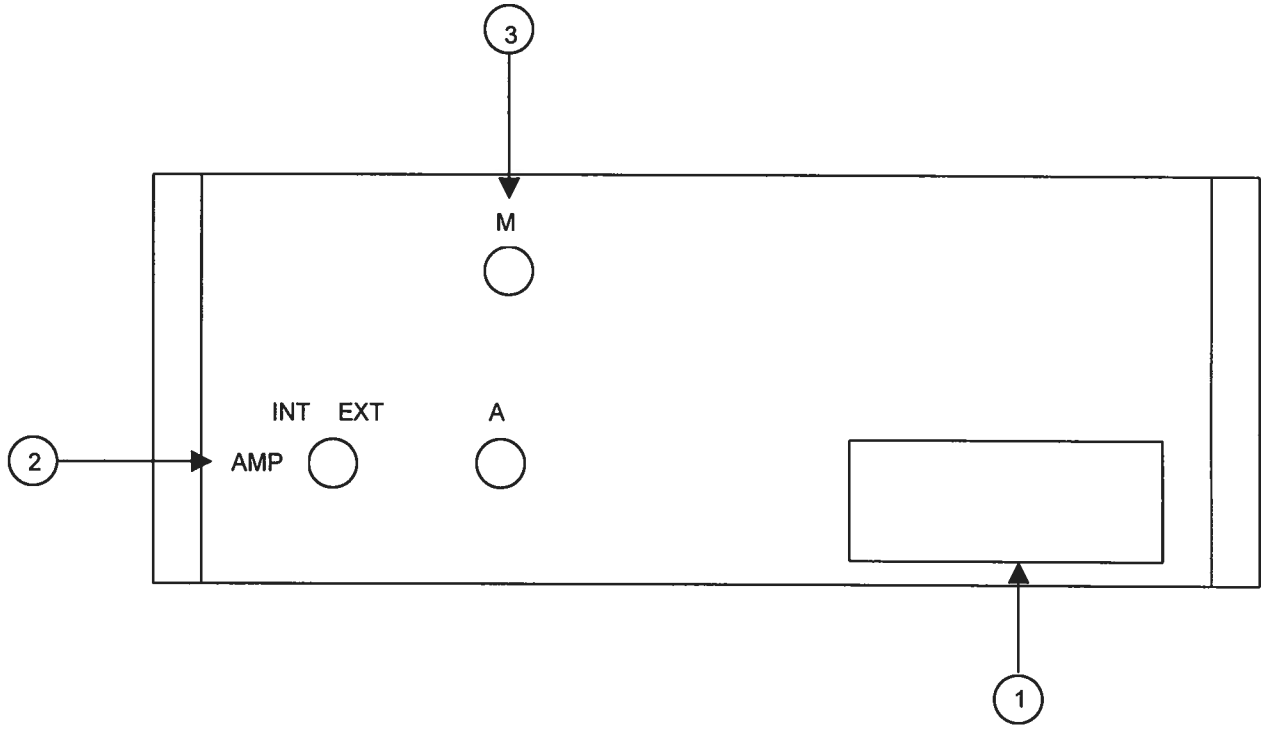

BACK PANEL CONTROLS

- (1) FUSED CONNECTOR, VOLTAGE SELECTOR. The detachable power cord is connected at this point. In addition, the removable cord is adjusted to select the desired input operating voltage. The unit also contains the main power fuse (0.5 A SB).
- (2) AMP. To voltage control the output amplitude, set the AMP switch in the EXT position and apply 0 to +10 VDC to the "A" BNC connector ($R_{IN} \geq 10K$).
- (3) The monitor output (-M) provides a 20 dB attenuated coincident replica of the main output to 50 Ohms. (option).

POWER SUPPLY AND FUSE REPLACEMENT

This instrument has three fuses (plus one spare). One, which protects the AC input, is located in the rear-panel power entry module, as described in the “Rear Panel Controls” section of this manual. If the power appears to have failed, check the AC fuse first.

The other two fuses (plus one spare) are located on the internal DC power supply, as shown below:

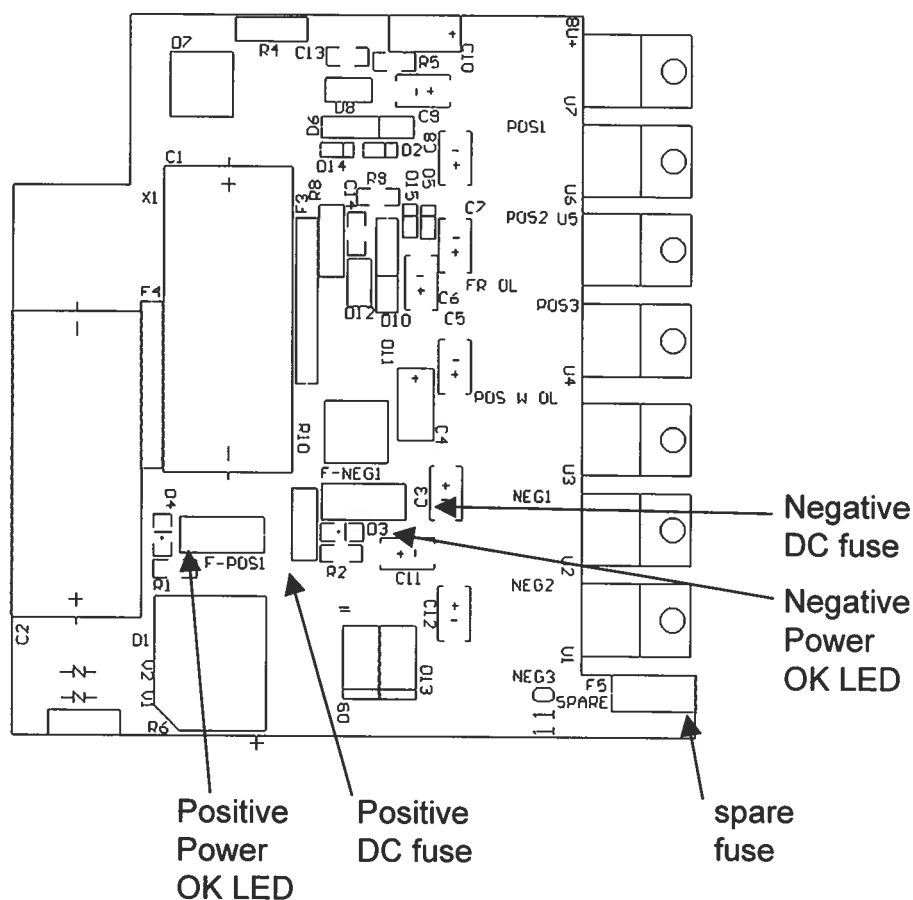

The spare fuse may be used to replace one of the other fuses, if required.

The three fuses on this circuit board are 0.5A slow-blow fuses, Littlefuse part number R452.500. (This fuse can be ordered from Digikey, www.digikey.com. The Digikey part number is F1341CT-ND).

If you suspect that the DC fuses are blown, follow this procedure:

1. Remove the top cover, by removing the four Phillips screws on the top cover and then sliding the cover back and off.
2. Locate the two "Power OK" LEDs on the power supply circuit board, as illustrated above.
3. Turn on the instrument.
4. Observe the "Power OK" LEDs. If the fuses are not blown, the two LEDs will be lit (bright red). If one of the LEDs is not lit, the fuse next to it has blown.
5. Turn off the instrument.
6. If a fuse is blown, use needle-nose pliers to remove the blown fuse from its surface-mount holder.
7. Replace the fuse.