

# AVTECH ELECTROSYSTEMS LTD.

NANOSECOND WAVEFORM ELECTRONICS  
ENGINEERING . MANUFACTURING

P.O. BOX 265  
OGDENSBURG  
□ NEW YORK  
13669  
(315) 472-5270

BOX 5120 STN. "F"  
OTTAWA, ONTARIO  
□ CANADA K2C 3H4  
(613) 226-5772  
TELEX 053.4591

## INSTRUCTIONS

MODEL AVG-3-PS IMPULSE GENERATOR

S.N. :

### WARRANTY

Avtech Electrosystems Ltd. warrants products of its manufacture to be free from defects in material and workmanship under conditions of normal use. If, within one year after delivery to the original owner, and after prepaid return by the original owner, this Avtech product is found to be defective, Avtech shall at its option repair or replace said defective item. This warranty does not apply to units which have been disassembled, modified or subjected to conditions exceeding the applicable specifications or ratings. This warranty is the extent of the obligation or liability assumed by Avtech with respect to this product and no other warranty or guarantee is either expressed or implied.

IMPULSE GENERATOR TEST ARRANGEMENT

110/220V  
50-60 Hz

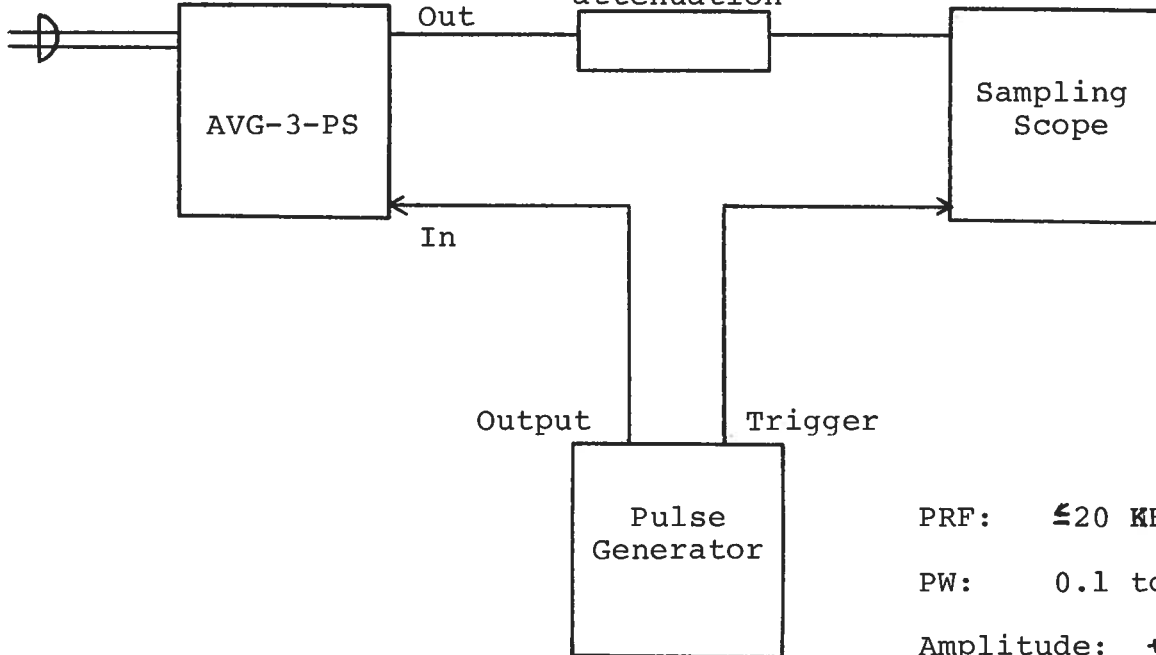

PRF:  $\leq 20$  KHz

PW: 0.1 to 1.0 usec

Amplitude: +3 to +5 volts  
(TTL Levels)

Notes:

- 1) The bandwidth capability of components and instruments used to display the impulse generator output signal (attenuators, cables, connectors, etc.) should exceed 1.0 gigahertz.
- 2) The use of 70 db attenuation will insure a peak input signal to the sampling scope of less than one volt.
- 3) In general, the pulse generator trigger delay control should be set in the 100 nsec. range. Other settings should be as shown in the above diagram. The impulse generator output is delayed with respect to the trigger input signal by about 70 nsec. (typically).
- 4) The impulse generator can withstand an infinite VSWR on the output port.

SYSTEM BLOCK DIAGRAM AND REPAIR PROCEDURE

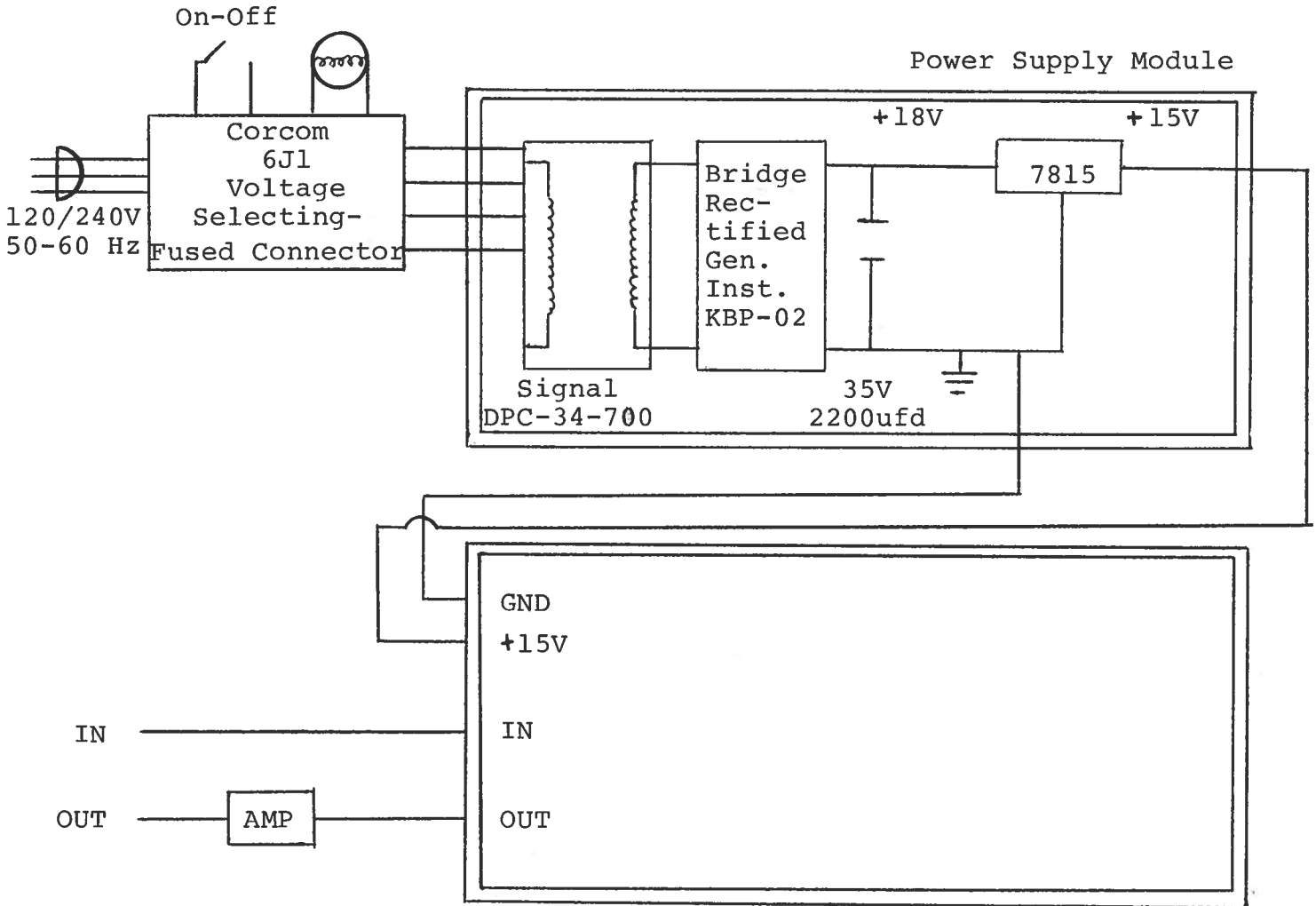

AVG-PG Module

## SYSTEM DESCRIPTION AND REPAIR PROCEDURE

The AVG-PS consists of a pulse generator module (AVG-PG) and a power supply board which supplies +15 volts (600 mA max) to the pulse generator module. In the event that the AVG-PS unit malfunctions, remove the instrument cover by removing the four Phillips screws on the back panel. The top cover may then be slid off. Measure the voltage at the +15 V pin of the PG module. If this voltage is substantially less than +15 volts, unsolder the line connecting the PS and PG modules and connect 50 ohm 10 W load to the PS output. The voltage across this load should be about 15 V DC. If this voltage is substantially less than 15 volts the PS module is defective and should be repaired or replaced. If the voltage across the resistor is near 15 volts, then the PG module should be replaced or repaired. The sealed PG module must be returned to Avtech for repair (or replacement).

Schroff

05.08.84

the 40,000 units of capital stock and the 10,000 units of preferred stock which are owned by the company and its subsidiaries. In the event the company should be liquidated, the assets of the company shall be sold and the proceeds thereof shall be distributed to the holders of the preferred stock first, and then to the holders of the common stock. The company shall not be liable for the payment of dividends on the preferred stock if it is not profitable to do so.