



**AVTECH ELECTROSYSTEMS LTD.**  
NANOSECOND WAVEFORM ELECTRONICS

---

P.O. BOX 265  
OGDENSBURG, NY  
U.S.A. 13669-0265  
TEL: (315) 472-5270  
FAX: (613) 226-2802

BOX 5120 STN. F  
OTTAWA, ONTARIO  
CANADA K2C 3H4  
TEL: (613) 226-5772  
FAX: (613) 226-2802

**INSTRUCTIONS**

**MODEL AVG-3A IMPULSE GENERATOR**

**S.N. :**

### WARRANTY

Avtech Electrosystems Ltd. warrants products of its manufacture to be free from defects in material and workmanship under conditions of normal use. If, within one year after delivery to the original owner, and after prepaid return by the original owner, this Avtech product is found to be defective, Avtech shall at its option repair or replace said defective item. This warranty does not apply to units which have been disassembled, modified or subjected to conditions exceeding the applicable specifications or ratings. This warranty is the extent of the obligation assumed by Avtech with respect to this product and no other warranty or guarantee is either expressed or implied.

### TECHNICAL SUPPORT

Phone: 613-226-5772 or 1-800-265-6681

Fax: 613-226-2802 or 1-800-561-1970

E-mail: [info@avtechpulse.com](mailto:info@avtechpulse.com)

World Wide Web: <http://www.avtechpulse.com>

IMPULSE GENERATOR TEST ARRANGEMENT

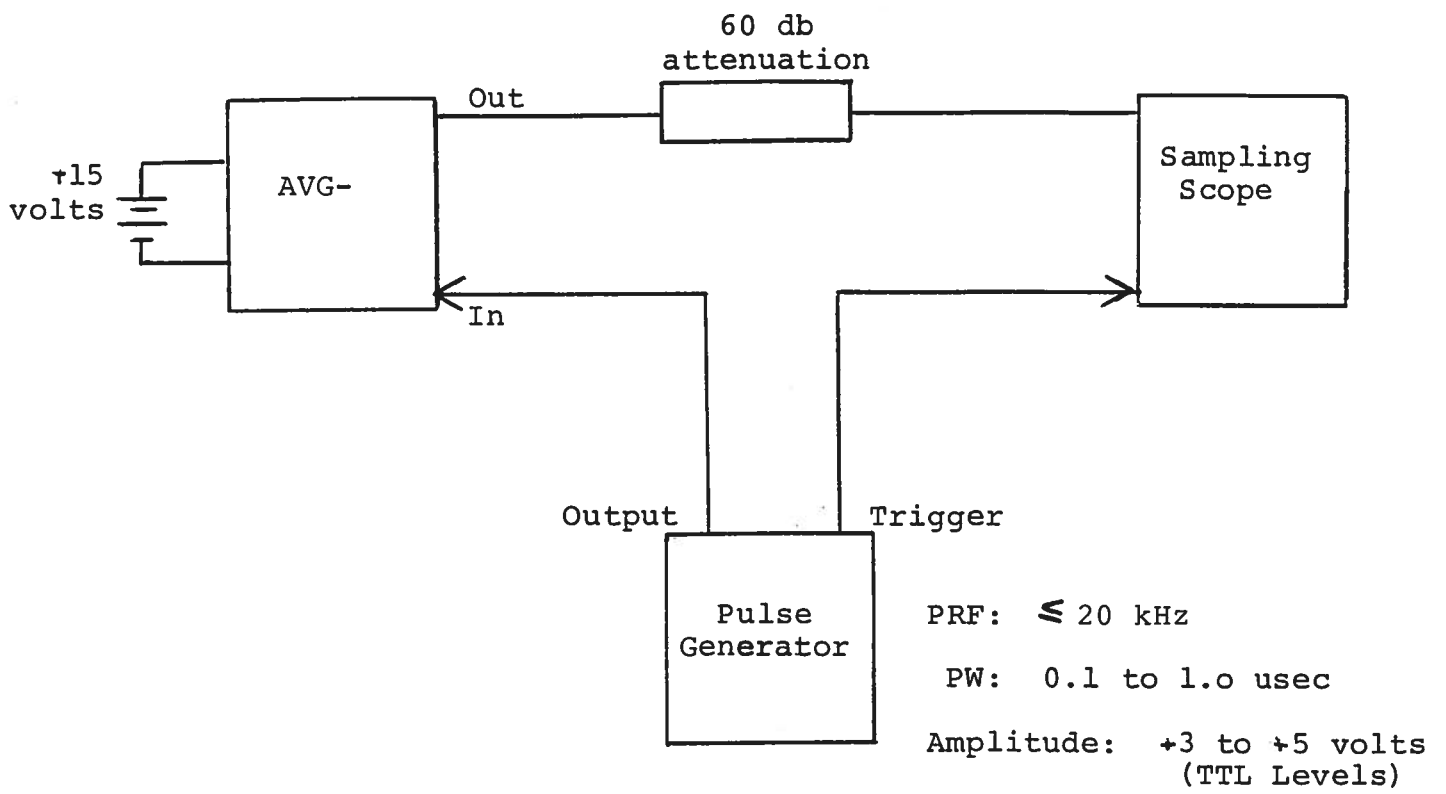

Notes:

- 1) The bandwidth capability of components and instruments used to display the pulse generator output signal (attenuators, cables, connectors, etc.) should exceed ten gigahertz.
- 2) The use of 60 db attenuator will insure a peak input signal to the sampling scope of less than one volt.
- 3) In general, the pulse generator trigger delay control should be set in the 100 nsec. range. Other settings should be as shown in the above diagram. The impulse generator output is delayed with respect to the trigger input signal by about 70 nsec. (typically).
- 4) The impulse generator can withstand an infinite VSWR on the output port.
- 5) The output amplitude is controlled by the one turn AMP control.

08.07.92

Edition A

10/10

11 The following is a list of the names of the persons who have been named in the above report. The names are given in the order in which they appear in the report. The names are given in the order in which they appear in the report. The names are given in the order in which they appear in the report.

- COA.4 - COA1

12 The name of the person named in the above report is given in the order in which they appear in the report. The names are given in the order in which they appear in the report.

13 The name of the person named in the above report is given in the order in which they appear in the report. The names are given in the order in which they appear in the report.

14 The name of the person named in the above report is given in the order in which they appear in the report. The names are given in the order in which they appear in the report.

15 The name of the person named in the above report is given in the order in which they appear in the report. The names are given in the order in which they appear in the report.