



AVTECH ELECTROSYSTEMS LTD.

NANOSECOND WAVEFORM ELECTRONICS
SINCE 1975

□ P.O. BOX 265
OGDENSBURG, NY
U.S.A. 13669-0265
TEL: (315) 472-5270
FAX: (613) 226-2802

TEL: 1-800-265-6681
FAX: 1-800-561-1970
U.S.A. & CANADA

✠ BOX 5120 STN. F
OTTAWA, ONTARIO
CANADA K2C 3H4
TEL: (613) 226-5772
FAX: (613) 226-2802

INSTRUCTIONS

MODEL AVG-4B-C-P-PN-M-OS PULSE GENERATOR

S.N. :

WARRANTY

Avtech Electrosystems Ltd. warrants products of its manufacture to be free from defects in material and workmanship under conditions of normal use. If, within one year after delivery to the original owner, and after prepaid return by the original owner, this Avtech product is found to be defective, Avtech shall at its option repair or replace said defective item. This warranty does not apply to units which have been disassembled, modified or subjected to conditions exceeding the applicable specifications or ratings. This warranty is the extent of the obligation or liability assumed by Avtech with respect to this product and no other warranty or guarantee is either expressed or implied.

Fig. 1

PULSE GENERATOR TEST ARRANGEMENT

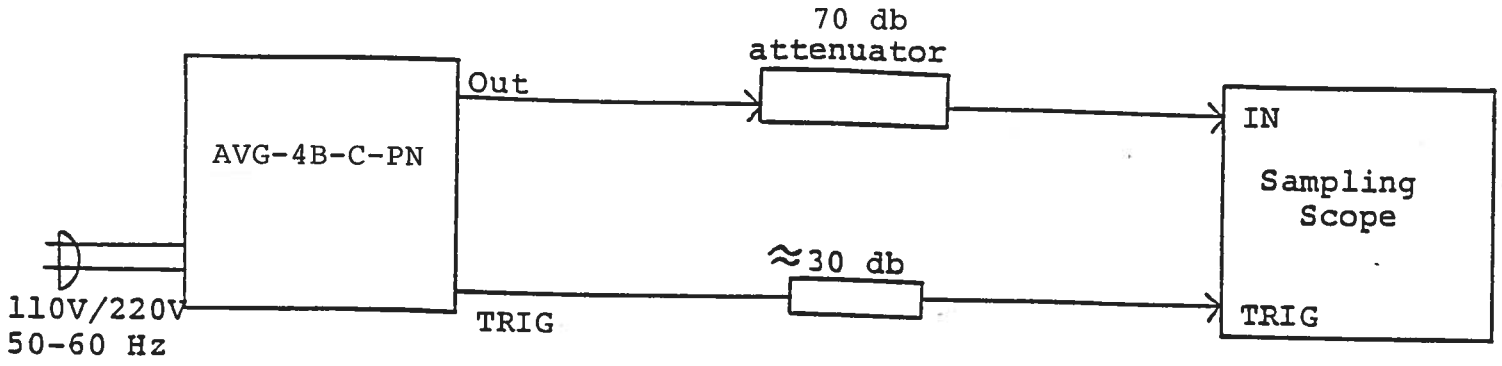

Notes:

- 1) The bandwidth capability of components and instruments used to display the pulse generator output signal (attenuators, cables, connectors, etc.) should exceed one gigahertz.
- 2) The use of 70 db attenuator at the sampling scope vertical input channel will insure a peak input signal to the sampling scope of less than one volt.
- 3) The TRIG output channel provides TTL level signals. To avoid overdriving the TRIG input channel of some sampling scopes, a 30 db attenuator should be placed at the input to the sampling scope trigger channel.
- 4) To obtain a stable output display the PRF control on the front panel should be set mid-range while the PRF range switch may be in either range. The front panel TRIG toggle switch should be in the INT position. The front panel DELAY controls and the scope triggering controls are then adjusted to obtain a stable output. With the ADVANCE-DELAY switch in the ADVANCE position, the TRIG output precedes the main output. With the switch in the DELAY position, the TRIG output lags the main output. The scope may then be used to set the desired PRF by rotating the PRF control and by means of the PRF range switch.
- 5) The output pulse amplitude is controlled by means of the one turn potentiometer (AMP).
- 6) MONITOR Output. The front panel monitor output provides an attenuated replica (20 db down) of the output. The monitor output is designed to operate into a 50 ohm load.
- 7) The general pulse shape is controlled by the following two controls:

PULSE WIDTH A: The main shape control. Clockwise rotation increases the pulse width (and amplitude).

PULSE WIDTH B: Should normally be set mid-range (to provide max output amplitude). Not a sensitive control.

After changing the PRF dramatically, it may be necessary to readjust the two controls to reobtain the desired output pulse shape.

- 8) The unit may be triggered externally by placing the INT-EXT switch in the EXT position and applying a TTL level pulse ($PW > 50$ ns) to the TRIG connector.
- 9) PN OPTION. The output polarity is controlled by the rear panel two-position polarity switch.
- 10) For additional assistance:
Tel: (613) 226-5772
Fax: (613) 226-2802

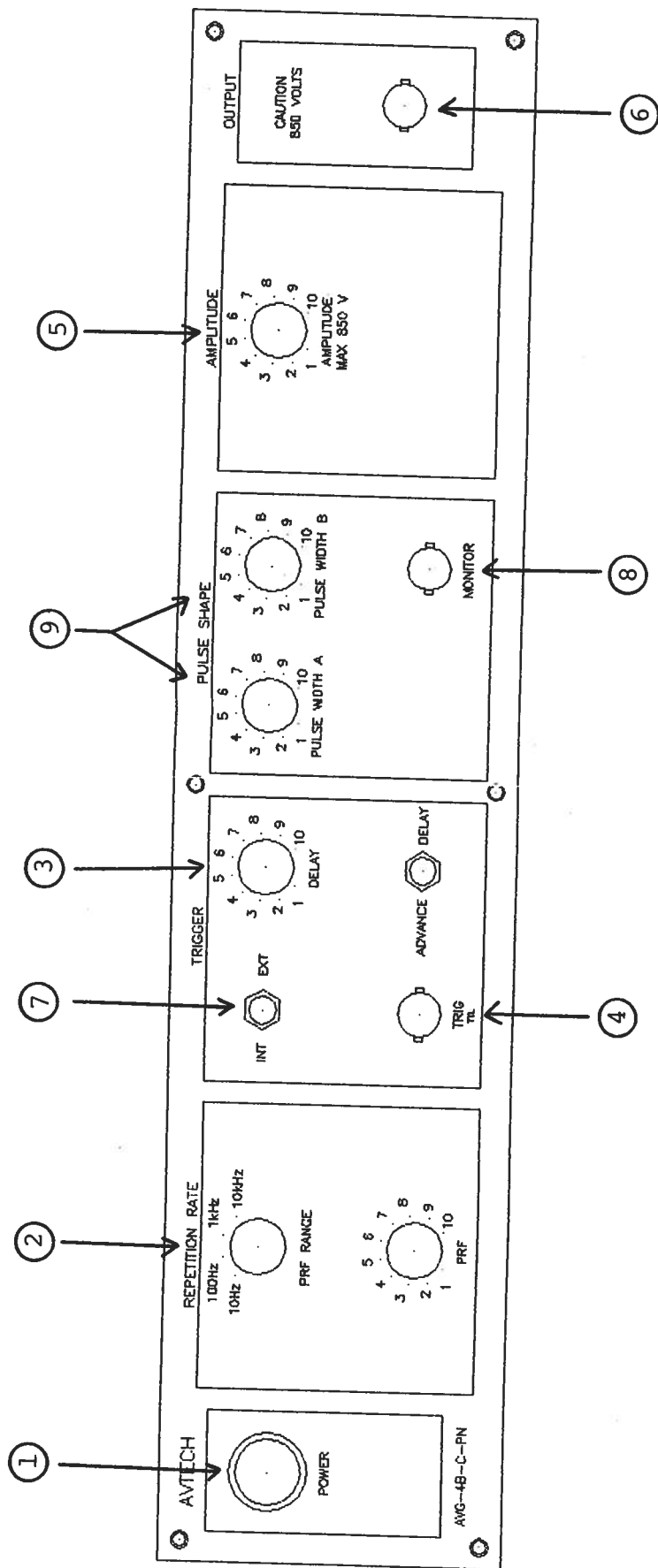

Fig. 2 FRONT PANEL CONTROLS

- (1) ON-OFF Switch. Applies basic prime power to all stages.
- (2) PRF Control. The PRF RANGE and PRF controls determine output PRF as follows:

PRF MIN	PRF MAX
1 Hz	10 Hz
10 Hz	100 Hz
100 Hz	1 kHz
1 kHz	10 kHz

- (3) DELAY Controls. Controls the relative delay between the reference output pulse provided at the TRIG output (4) and the main output (6). This delay is variable over the range of 0 to about 100 ns. The TRIG output precedes the main output when the ADVANCE-DELAY switch is in the ADVANCE position and lags when the switch is in the DELAY position.
- (4) TRIG Output. The output is a TTL level 100 ns (approx) pulse capable of driving a fifty ohm load. The external trigger signal is applied at this input when the EXT-INT toggle switch is in the EXT position.
- (5) AMP Control. The output pulse amplitude is controlled by means of the one turn potentiometer.
- (6) OUT. BNC connector applies output to 50 ohm load.
- (7) EXT-INT Control. With this toggle switch in the INT position, the PRF of the AVG unit is controlled via an internal clock which in turn is controlled by the PRF controls. With the toggle switch in the EXT position, the AVG unit requires a TTL level pulse (PW > 50 ns) applied at the TRIG input in order to trigger the output stages. In addition, in this mode, the scope time base must be triggered by the external trigger source.
- (8) MONITOR Output. The front panel monitor output provides an attenuated replica (20 db down) of the output. The monitor output is designed to operate into a 50 Ohm load (option).
- (9) PULSE SHAPE. The general pulse shape is controlled by the following two controls:

PULSE WIDTH A: The main shape control. Clockwise rotation increases the pulse width (and amplitude).

PULSE WIDTH B: Should normally be set mid-range (to provide max output amplitude). Not a sensitive control.

Fig. 3

BACK PANEL CONTROLS

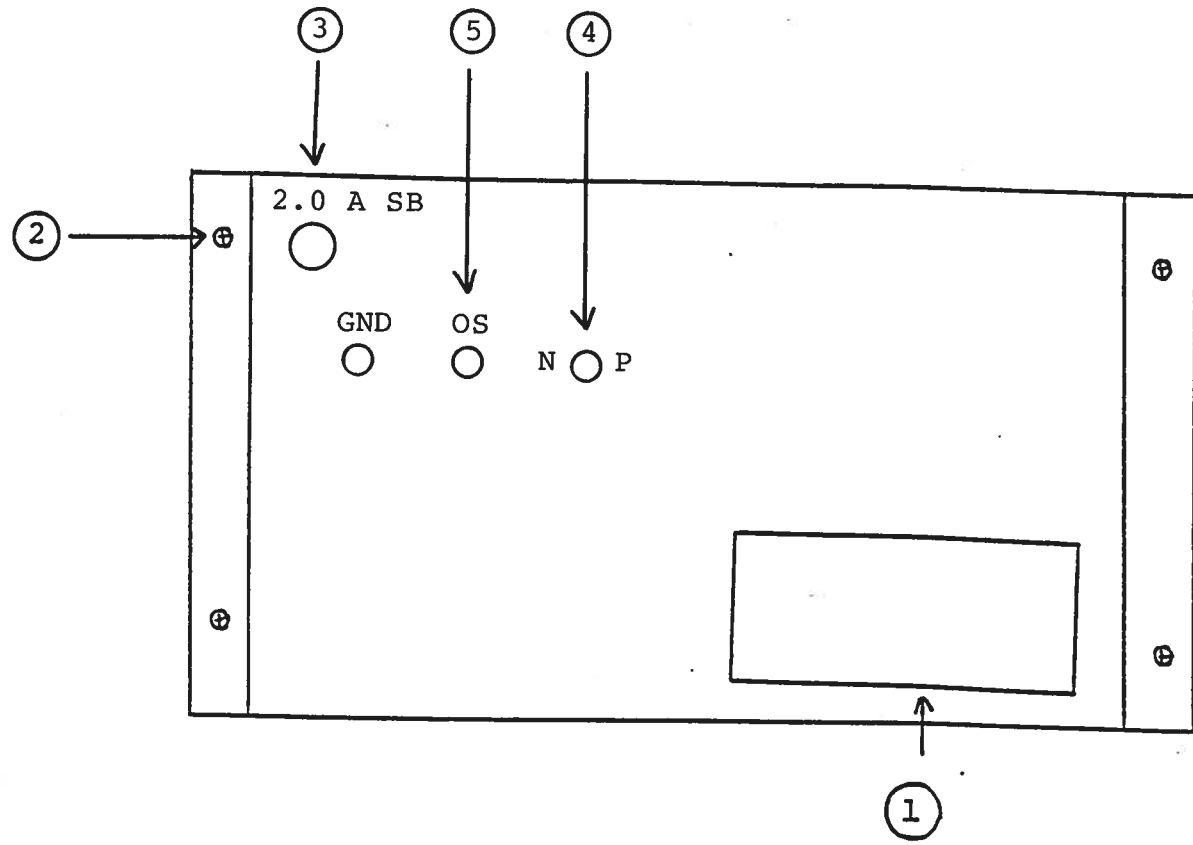

- (1) FUSED CONNECTOR, VOLTAGE SELECTOR. The detachable power cord is connected at this point. In addition, the removable cord is adjusted to select the desired input operating voltage. The unit also contains the main power fuse (0.5 A SB).
- (2) TOP COVER REMOVAL. Remove the 4 Phillips screws on the back cover. The top cover may then be slid back (and off).
- (3) 2.0 A SB. Fuse which limits the current provided to the output stage so as to protect against overload.
- (4) POLARITY Switch. Two-position switch controls the polarity of the output pulse.
- (5) OS. A DC offset may be applied to the output pulse by applying the desired potential to the rear panel solder terminal (+50 Volts max, +100 mA max).

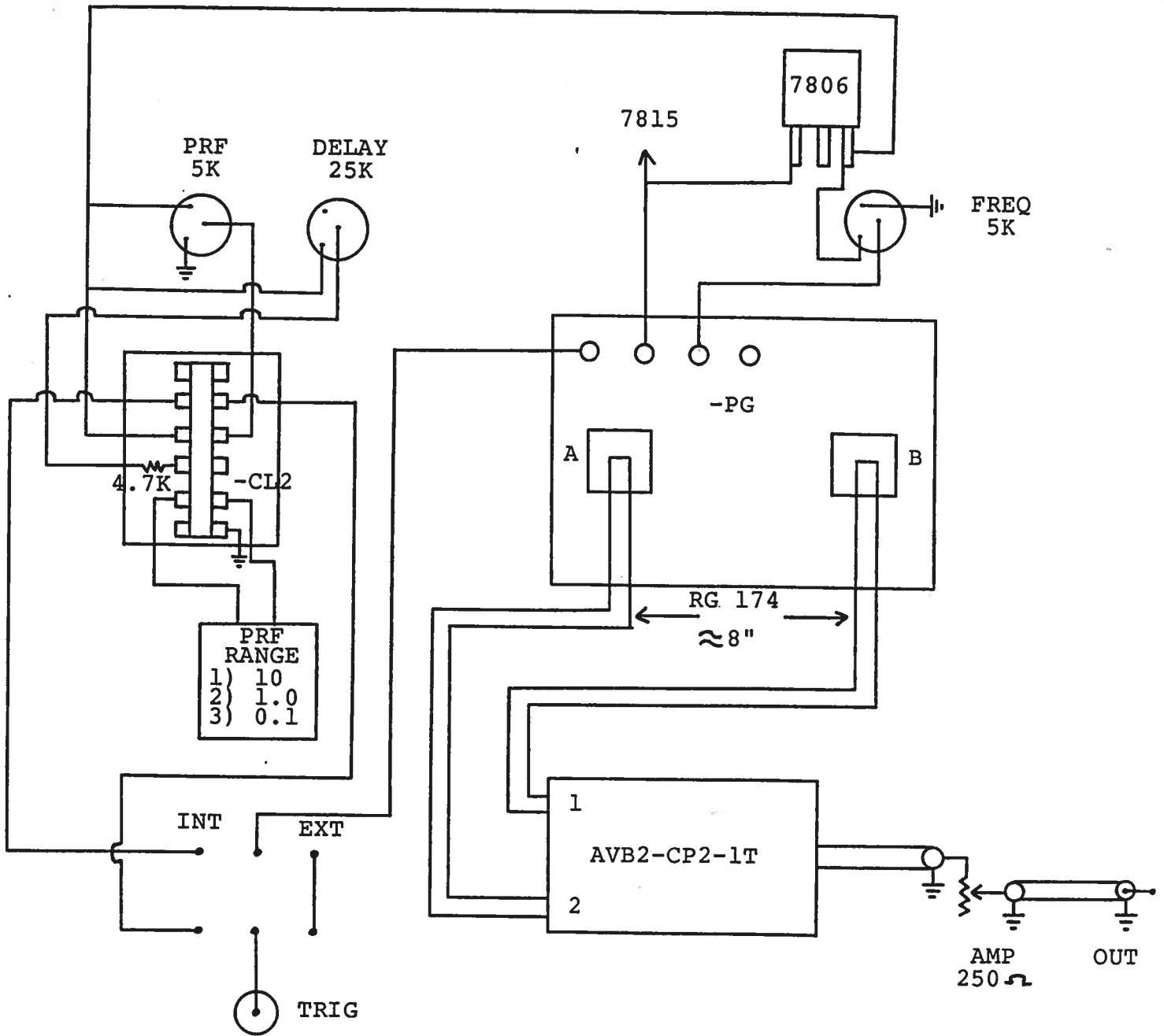

AVB2-TC-C BLOCK DIAGRAM

POWER SUPPLY

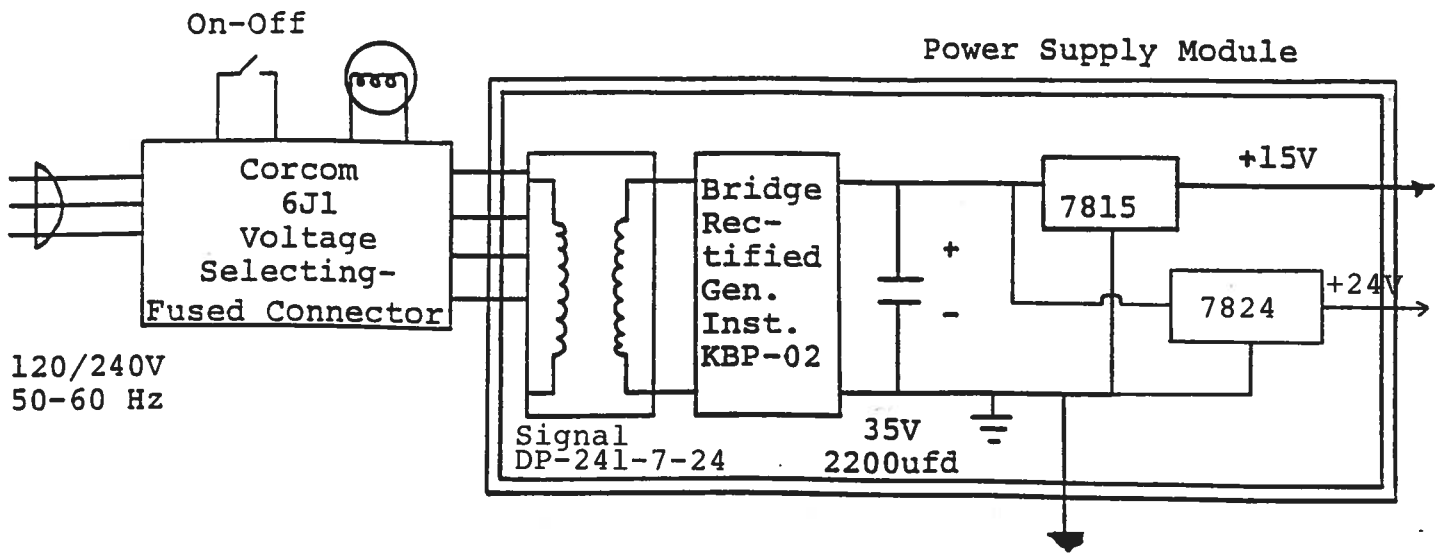

SYSTEM DESCRIPTION AND REPAIR PROCEDURE

The AVG-4B-C consists of one pulse generator module (AVG-4B-PG), one power combiner module (AVX-CP-3), a power supply module (-PS-11), an amplitude control module (-EA) a clock module and a power supply board which supplies +15 volts (1.5 A max) to the pulse generator modules. In the event that the unit malfunctions, remove the instrument cover by removing the four Phillips screws on the back panel of the unit. The top cover may then be slid off. Measure the voltage at the +15 V pin of the PG module. If this voltage is substantially less than +15 volts, unsolder the line connecting the power supply and PG modules and connect 100 ohm 10 W load to the PS output. The voltage across this load should be about +15V DC. If this voltage is substantially less than 15 volts the PS module is defective and should be repaired or replaced. If the voltage across the resistor is near 15 volts, then the PG modules should be replaced or repaired. The sealed PG modules must be returned to Avtech for repair (or replacement). The clock module provides a 0.1 us TTL level trigger pulse at Pin 2 to trigger the PG module and a 0.1 us TTL level sync pulse at Pin 3 to trigger the sampling scope display device. The output at Pin 3 precedes the output at Pin 2 by almost 0 to 100 ns depending on the DELAY control setting. The clock module is powered by +5.0 V supplied by the 7805. With the INT-EXT switch in the EXT position, the clock module is disconnected from the PG module. The clock module is functioning properly if:

- a) 0.1 us TTL level outputs are observed at Pins 2 and 3.
- b) The PRF of the outputs can be varied over the range of 1 Hz to 10 kHz using the PRF and PRF RANGE controls.
- c) The relative delay between the Pin 2 and 3 outputs can be varied by at least 100 ns by the DELAY control.

The sealed clock module must be returned to Avtech for repair or replacement if the above conditions are not observed.

Dec. 24/93