



AVTECH ELECTROSYSTEMS LTD.

NANOSECOND WAVEFORM ELECTRONICS
SINCE 1975

□ P.O. BOX 265
OGDENSBURG, NY
U.S.A. 13669-0265
TEL: (315) 472-5270
FAX: (613) 226-2802

TEL: 1-800-265-6681
FAX: 1-800-561-1970
U.S.A. & CANADA

□ BOX 5120 STN. F
OTTAWA, ONTARIO
CANADA K2C 3H4
TEL: (613) 226-5772
FAX: (613) 226-2802

INSTRUCTIONS

MODEL AVI-V-HV1-C PULSE GENERATOR

S.N.:

WARRANTY

Avtech Electrosystems Ltd. warrants products of its manufacture to be free from defects in material and workmanship under conditions of normal use. If, within one year after delivery to the original owner, and after prepaid return by the original owner, this Avtech product is found to be defective, Avtech shall at its option repair or replace said defective item. This warranty does not apply to units which have been disassembled, modified or subjected to conditions exceeding the applicable specifications or ratings. This warranty is the extent of the obligation assumed by Avtech with respect to this product and no other warranty or guarantee is either expressed or implied.

TECHNICAL SUPPORT

Phone: 613-226-5772 or 1-800-265-6681

Fax: 613-226-2802 or 1-800-561-1970

E-mail: info@avtechpulse.com

World Wide Web: <http://www.avtechpulse.com>

Fig. 1

PULSE GENERATOR TEST ARRANGEMENT

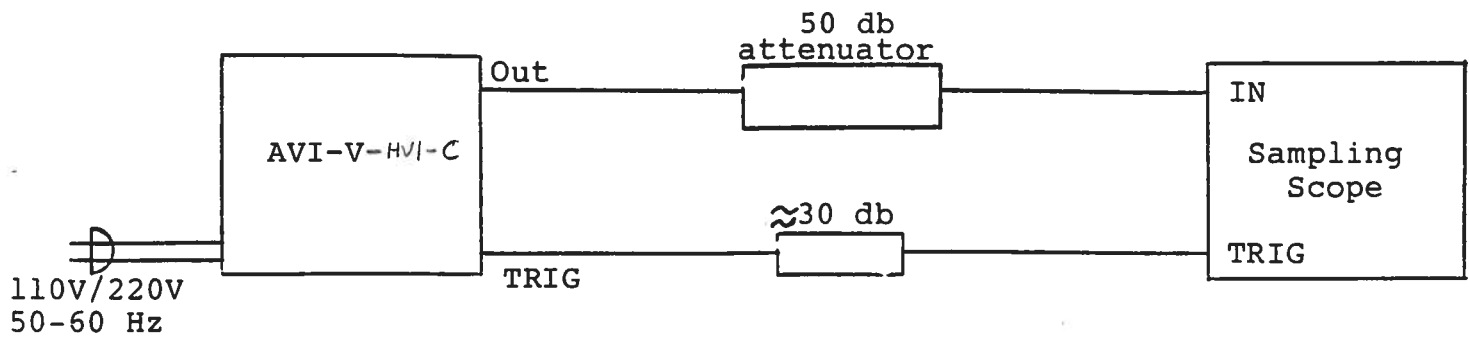

Notes:

- 1) The bandwidth capability of components and instruments used to display the pulse generator output signal (attenuators, cables, connectors, etc.) should exceed five gigahertz.
- 2) The use of 50 dB attenuator at the sampling scope vertical input channel will insure a peak input signal to the sampling scope of less than one Volt.
- 3) The TRIG output channel provides TTL level signals. To avoid overdriving the TRIG input channel of some scopes, a 30 dB attenuator should be placed at the input to the scope trigger channel. The TRIG output precedes the main output when the front panel ADVANCE-DELAY switch is in the ADVANCE position. The TRIG output lags the main output when the switch is in the DELAY position.
- 4) To obtain a stable output display the PRF controls on the front panel should be set mid-range while the PRF switch may be in either range. The front panel TRIG toggle switch should be in the INT position. The front panel DELAY control and the scope triggering controls are then adjusted to obtain a stable output. The scope may then be used to set the desired PRF by rotating the PRF controls.
- 5) The output pulse width is controlled by means of the front panel one turn PW control. The control should initially be set maximum clockwise and the pulse width adjusted using an oscilloscope.
- 6) The output pulse amplitude is controlled by means of the front panel one turn AMP control.
- 7) Some properties of the output pulse may change as a function of the amplitude pot setting. For some demanding applications, it may be desirable to use a combination of external attenuators and the amplitude pot to achieve the desired output amplitude.
- 8) To DC offset the output pulse connect a DC power supply set to required DC offset value to the back panel terminals marked O.S. The maximum attainable DC offset voltage is +50 Volts. (option)

- 9) An external clock may be used to control the output PRF of the AVI unit by setting the front panel TRIG toggle switch in the EXT position and applying a 0.2 us (approx.) TTL level pulse to the TRIG BNC connector input. For operation in this mode, the scope time base must also be triggered by the external clock. The propagation delay time in the externally triggered mode is about 300 ns.
- 10) To invert the output of units with the dual output polarity option (-PN), connect the AVX-3 module to the output port of the AVI unit. An inverted pulse is then obtained at the out port of the AVX-3 module.
- 11) To invert the output of units with the dual output polarity option (-PN) and the offset option (OS), connect the AVX-3-T module to the OUT port of the AVI unit. A negative pulse with a rise time <200 psec is then obtained at the OUT port of the AVX-3-T unit. To offset the negative pulse, apply the required DC level to the DC terminal of the AVX-3-T unit.
- 12) MONITOR OUT M. Provides an attenuated (x10) coincident replica of the main positive output pulse to fifty Ohms. (option).
- 13) The unit can be converted from 110 to 220V 50-60 Hz operation by adjusting the voltage selector card in the rear panel fused voltage selector-cable connector assembly.
- 14) For additional assistance:

Tel: (613) 226-5772
Fax: (613) 226-2802

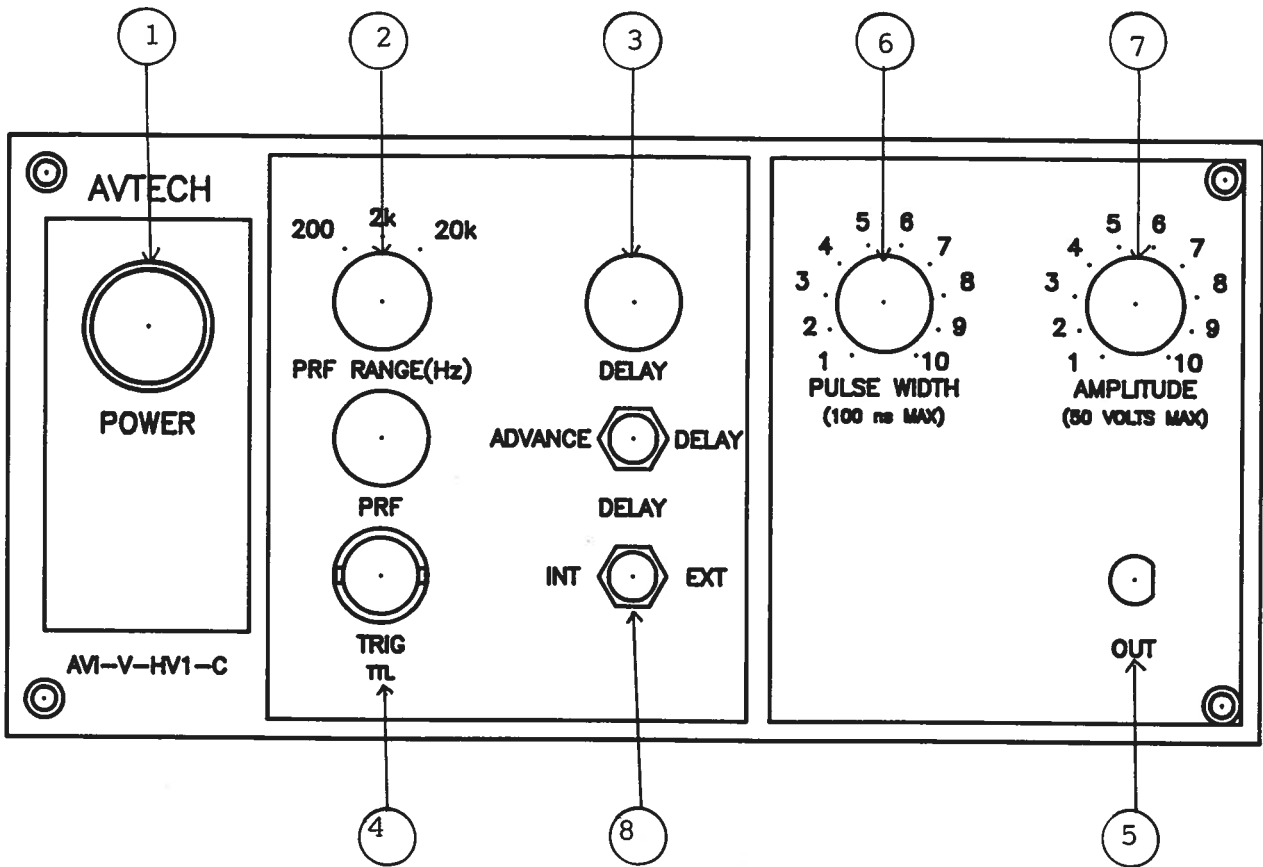

Fig. 2. FRONT PANEL CONTROLS

- (1) ON-OFF Switch. Applies basic prime power to all stages.
- (2) PRF Control. Varies PRF from 10 Hz to 5 kHz as follows:

Range 1	20 Hz	to	200 Hz
Range 2	200 Hz	to	2.0 kHz
Range 3	2.0 kHz	to	20 kHz
- (3) DELAY Control. Controls the relative delay between the reference output pulse provided at the TRIG output (4) and the main output (5). This delay is variable over the range of 0 to about 0.5 us (RANGE 1) and 0.5 to 5.0 us (RANGE 2). The TRIG output precedes the main output when the ADVANCE-DELAY switch is in the ADVANCE position and lags when the switch is in the DELAY position.
- (4) TRIG Output. This output is used to trigger the scope time base. The output is a TTL level 100 ns (approx.) pulse capable of driving a fifty Ohm load.
- (5) OUT Connector. SMA connector provides output to a fifty Ohm load.
- (6) PW Control. A one turn control which varies the output pulse width.
- (7) AMP Control. A one turn control which varies the output pulse amplitude from 0 to 100V to a fifty Ohm load.
- (8) EXT-INT Control. With this toggle switch in the INT position, the PRF of the AVI unit is controlled via an internal clock which in turn is controlled by the PRF controls. With the toggle switch in the EXT position, the AVI unit requires a 0.2 us TTL level pulse applied at the TRIG input in order to trigger the output stages. In addition, in this mode, the scope time base must be triggered by the external trigger source.

Fig. 3

BACK PANEL CONTROLS

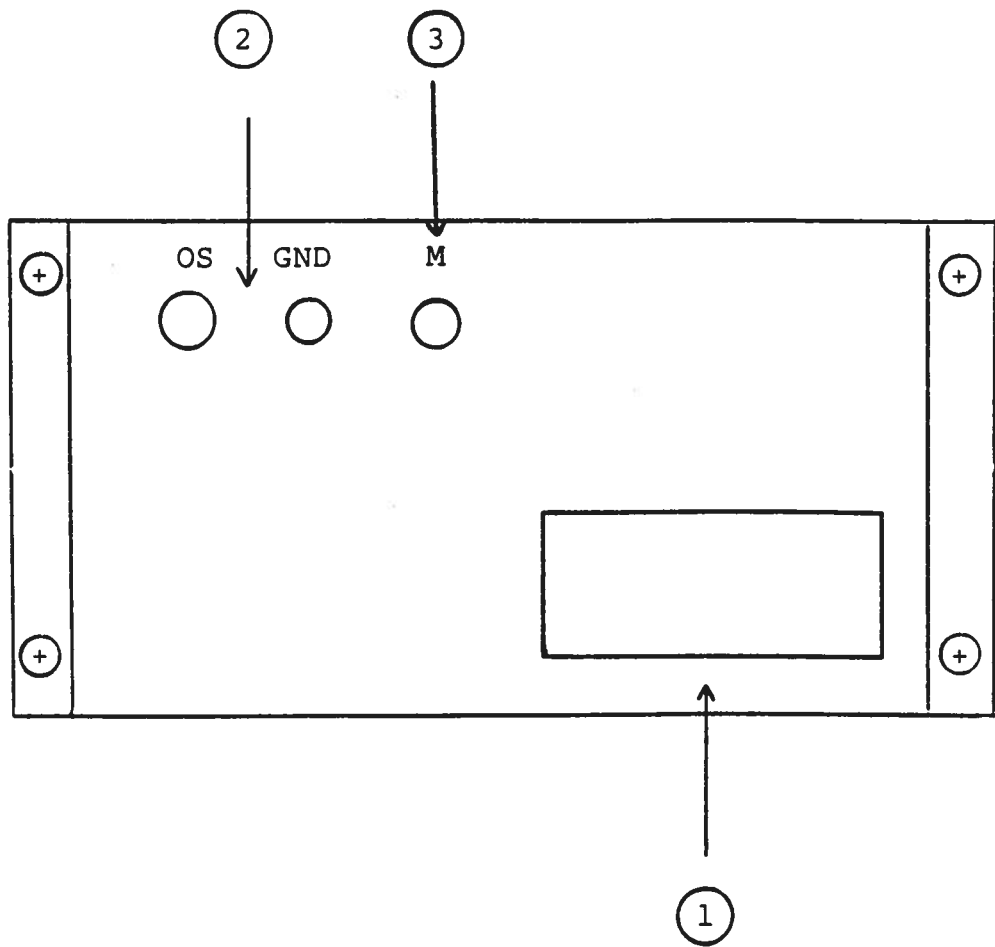

- (1) FUSED CONNECTOR, VOLTAGE SELECTOR. The detachable power cord is connected at this point. In addition, the removable cord is adjusted to select the desired input operating voltage. The unit also contains the main power fuse (0.25 A SB).
- (2) DC OFFSET Input. To DC offset the output pulse, connect a DC power supply set to the desired offset value to these terminals. The maximum allowable DC offset voltage is +50 Volts (option).
- (3) MONITOR OUT M. Provides an attenuated (x10) coincident replica of the main positive output pulse to fifty Ohms. (option).

Fig. 4

SYSTEM BLOCK DIAGRAM

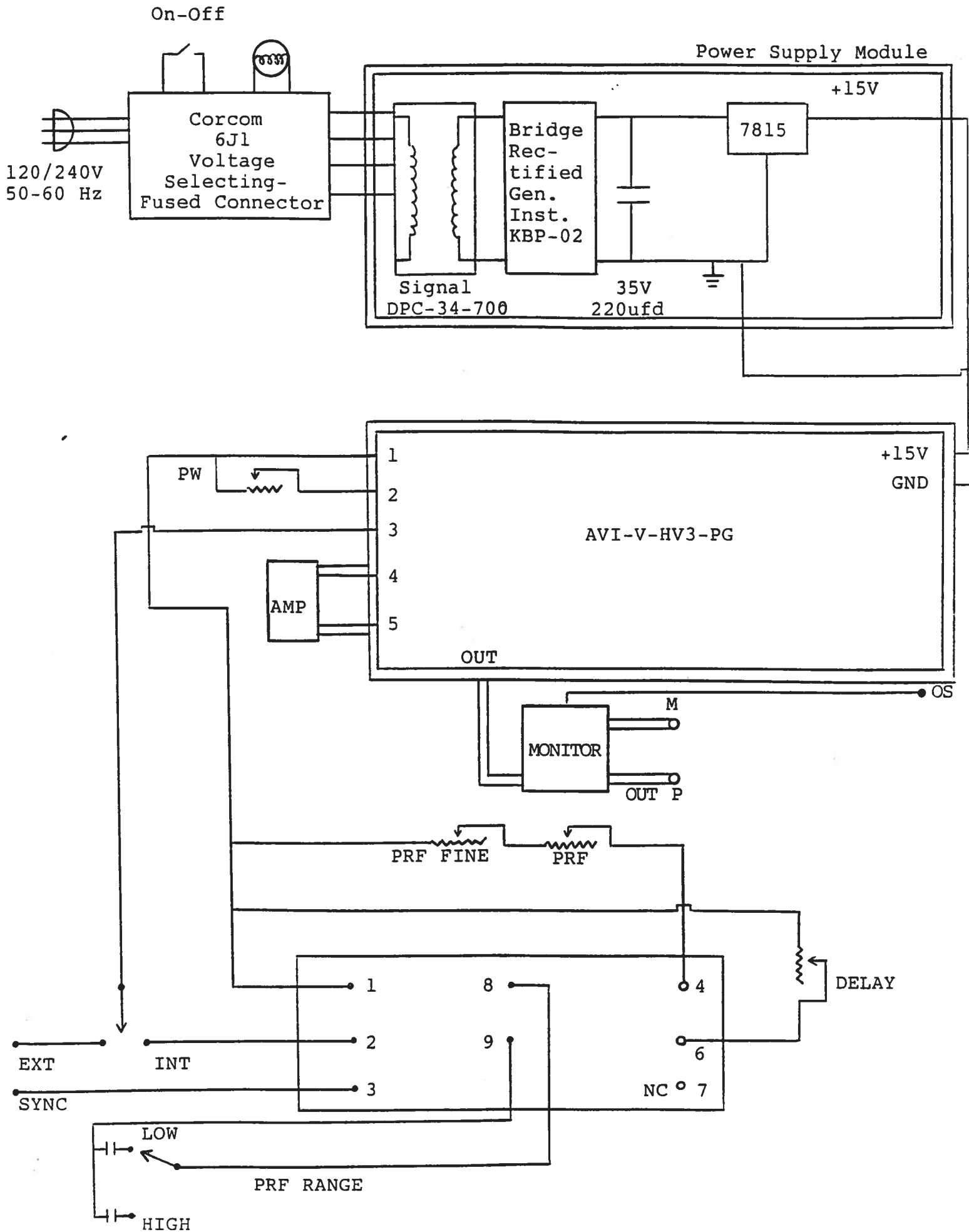

SYSTEM DESCRIPTION AND REPAIR PROCEDURE

The AVI-V-C consists of a pulse generator module (AVI-V-PG), a clock module AVI-V-CL and a power supply board which supplies +15 Volts (600 mA max) to the pulse generator module. In the event that the unit malfunctions, remove the instrument cover by removing the 4 Phillips screws on the back panel of the unit. The top cover may then be slid off. Measure the voltage at the +15 V pin of the PG module. If this voltage is substantially less than +15 Volts, unsolder the line connecting the power supply and PG modules and connect 50 Ohm 10 W load to the PS output. The voltage across this load should be about +15 V DC. If this voltage is substantially less than 15 Volts the PS module is defective and should be repaired or replaced. If the voltage across the resistor is near 15 Volts, then the PG module should be replaced or repaired. The sealed PG module must be returned to Avtech for repair (or replacement). The clock module provides a 0.1 us TTL level trigger pulse at pin 2 to trigger the PG module and a 0.1 us TTL level sync pulse at pin 3 to trigger the sampling scope display device. The output at pin 3 precedes the output at pin 2 by almost 0 to 100 ns depending on the DELAY control setting. The clock module is powered by +5.8 V supplied by the PG module (from pin 5 to pin 1). With the INT-EXT switch in the EXT position, the clock module is disconnected from the PG module. The clock module is functioning properly if:

- a) 0.1 us TTL level outputs are observed at pins 2 and 3.
- b) The PRF of the outputs can be varied over the range of 0.05 kHz to 5 kHz using the PRF and PRF RANGE controls.
- c) The relative delay between the pin 2 and 3 outputs can be varied by at least 100 ns by the DELAY control.

The sealed clock module must be returned to Avtech for repair or replacement if the above conditions are not observed.

Aug 3V94

edition C