

# AVTECH ELECTROSYSTEMS LTD.

NANOSECOND WAVEFORM ELECTRONICS  
ENGINEERING - MANUFACTURING

□ P.O. BOX 265  
OGDENSBURG  
NEW YORK  
13669  
(315) 472.5270

☒ BOX 5120 STN. "F"  
OTTAWA, ONTARIO  
CANADA K2C 3H4  
(613) 226-5772  
TELEX 053-4591

## INSTRUCTIONS

MODEL AVK-A-C PULSE GENERATOR

S.N. :

### WARRANTY

Avtech Electrosystems Ltd. warrants products of its manufacture to be free from defects in material and workmanship under conditions of normal use. If, within one year after delivery to the original owner, and after prepaid return by the original owner, this Avtech product is found to be defective, Avtech shall at its option repair or replace said defective item. This warranty does not apply to units which have been disassembled, modified or subjected to conditions exceeding the applicable specifications or ratings. This warranty is the extent of the obligation or liability assumed by Avtech with respect to this product and no other warranty or guarantee is either expressed or implied.

PULSE GENERATOR TEST ARRANGEMENT

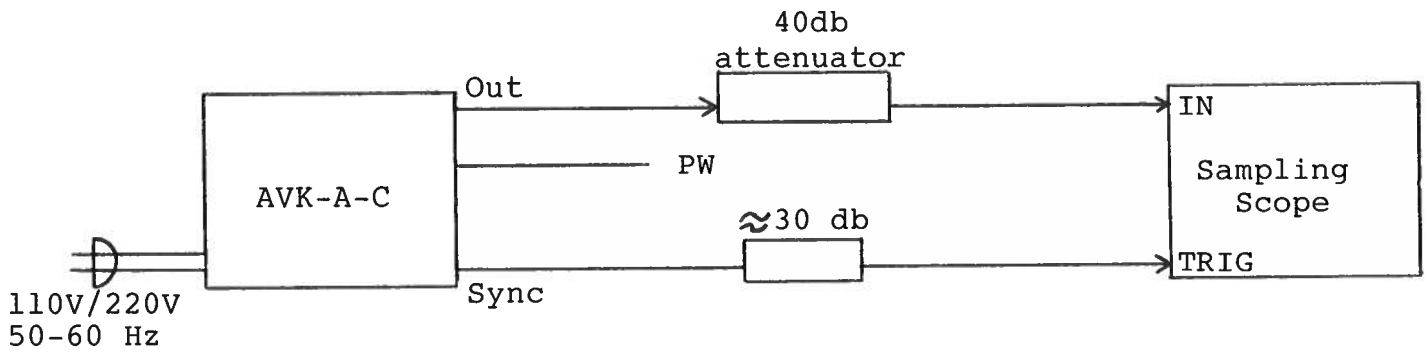

Notes:

- 1) The bandwidth capability of components and instruments used to display the pulse generator output signal (attenuators, cables, connectors, etc.) should exceed ten gigahertz.
- 2) The use of 40 db attenuator at the sampling scope vertical input channel will insure a peak input signal to the sampling scope of less than one volt.
- 3) The sync output channel provides TTL level signals. To avoid overdriving the TRIG input channel of some sampling scopes, a 30 db attenuator should be placed at the input to the sampling scope trigger channel.
- 4) To obtain a stable output display the PRF and PRF FINE controls on the front panel should be set mid-range while the PRF range switch may be in either range. The front panel TRIG toggle switch should be in the INT position. The front panel DELAY control and the scope triggering controls are then adjusted to obtain a stable output. The scope may then be used to set the desired PRF by rotating the PRF and PRF FINE controls and by means of the PRF range switch.
- 5) The Model AVK output pulse width is a linear function of the length of open circuited coaxial cable connected to the "PW" port (see Fig. 1). The open circuited delay line should be formed from high-quality semi-rigid 50 ohm coaxial cable (eg. 0.085 inch copper 50 ohm semi-rigid). Miniature flexible coaxial cable such as RG 174 may be used but may result in a degraded fall time. In the absence of an external cable connected to the tune port, Model AVK outputs a 4 nsec pulse.
- 6) The minimum pulse repetition frequency period is related to the delay line cable length (or pulse width) as shown in Fig. 2. If the PRF period for a given cable length is less than that specified in Fig. 2, the output pulse amplitude will be less than the specified value and prolonged operation in this mode could result in damage to the unit. Therefore, operation in or beyond the shaded region should be avoided.
- 7) The Model AVK pulse generator can withstand an infinite VSWR on the output port.
- 8) The output pulse amplitude is controlled by means of the front panel one turn AMP control.

- 9) Some properties of the output pulse may change as a function of the amplitude pot setting. For some demanding applications, it may be desirable to use a combination of external attenuators and the amplitude pot to achieve the desired output amplitude.
- 10) An external clock may be used to control the output PRF of the AVK unit by setting the front panel TRIG toggle switch in the EXT position and applying a 0.2 usec (approx.) TTL level pulse to the TRIG BNC connector input. For operation in this mode, the scope time base must also be triggered by the external clock rather than from the SYNC output.
- 11) The unit can be converted from 110 to 220V 50-60 Hz operation by adjusting the voltage selector card in the rear panel fused voltage selector-cable connector assembly.
- 12) For units with the dual output polarity option (-PN) a positive output pulse is obtained at the OUT SMA connector. To obtain a negative output pulse, connect the AVX-3 module to the OUT SMA connector. A negative output pulse is then obtained at the output of the AVX-3 module.
- 13) To DC offset the output pulse connect a DC power supply set to the required DC offset value to the terminals marked D.S. The maximum attainable DC offset voltage is  $\pm 50$  volts (option).
- 14) The monitor output port (M) provides an attenuated (20 db,  $\times 10$ ) coincident replica of the main output to 50 ohms (-M option).

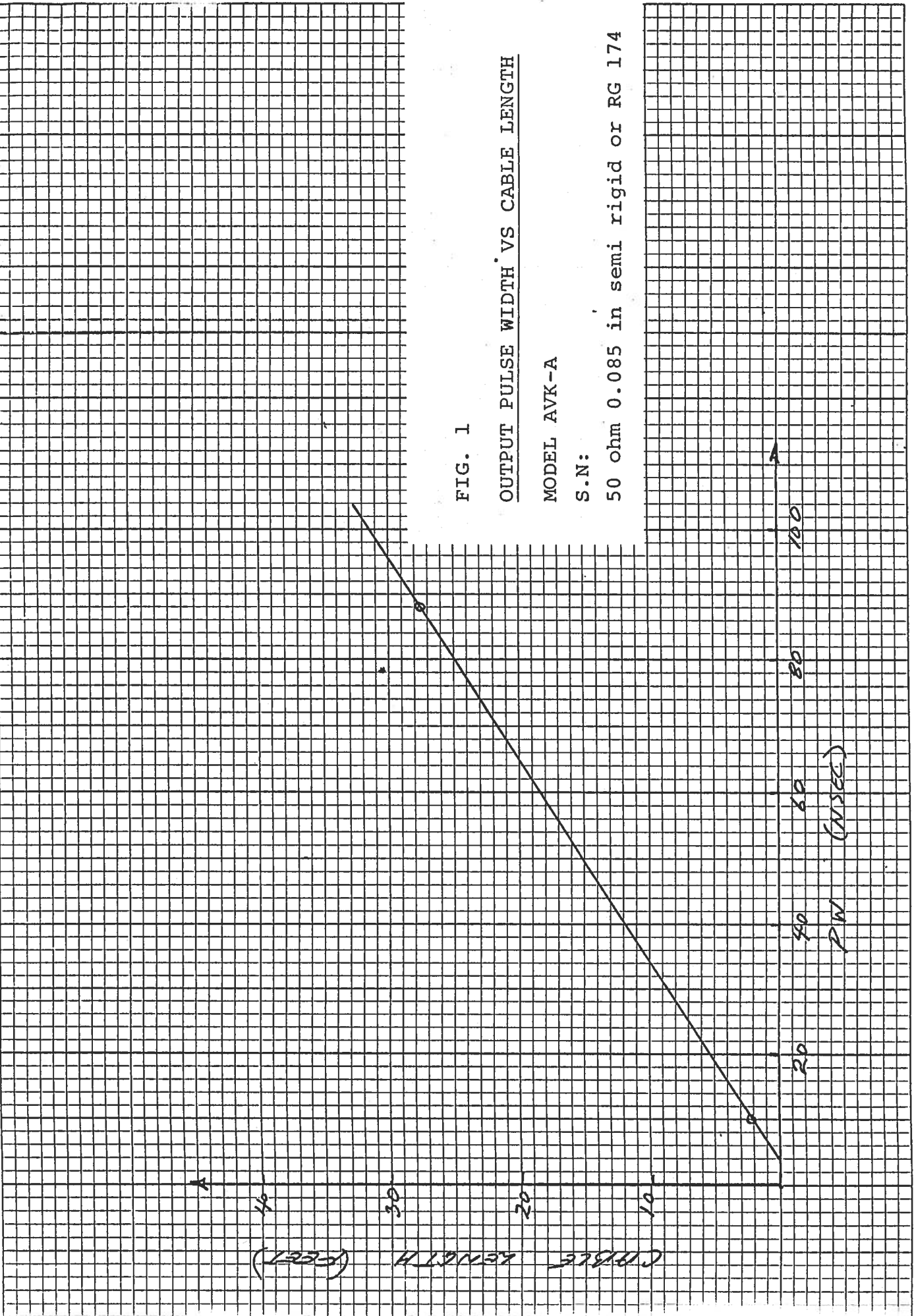

FIG. 1

OUTPUT PULSE WIDTH VS CABLE LENGTH

MODEL AVK-A

S.N:

50 ohm 0.085 in semi rigid or RG 174

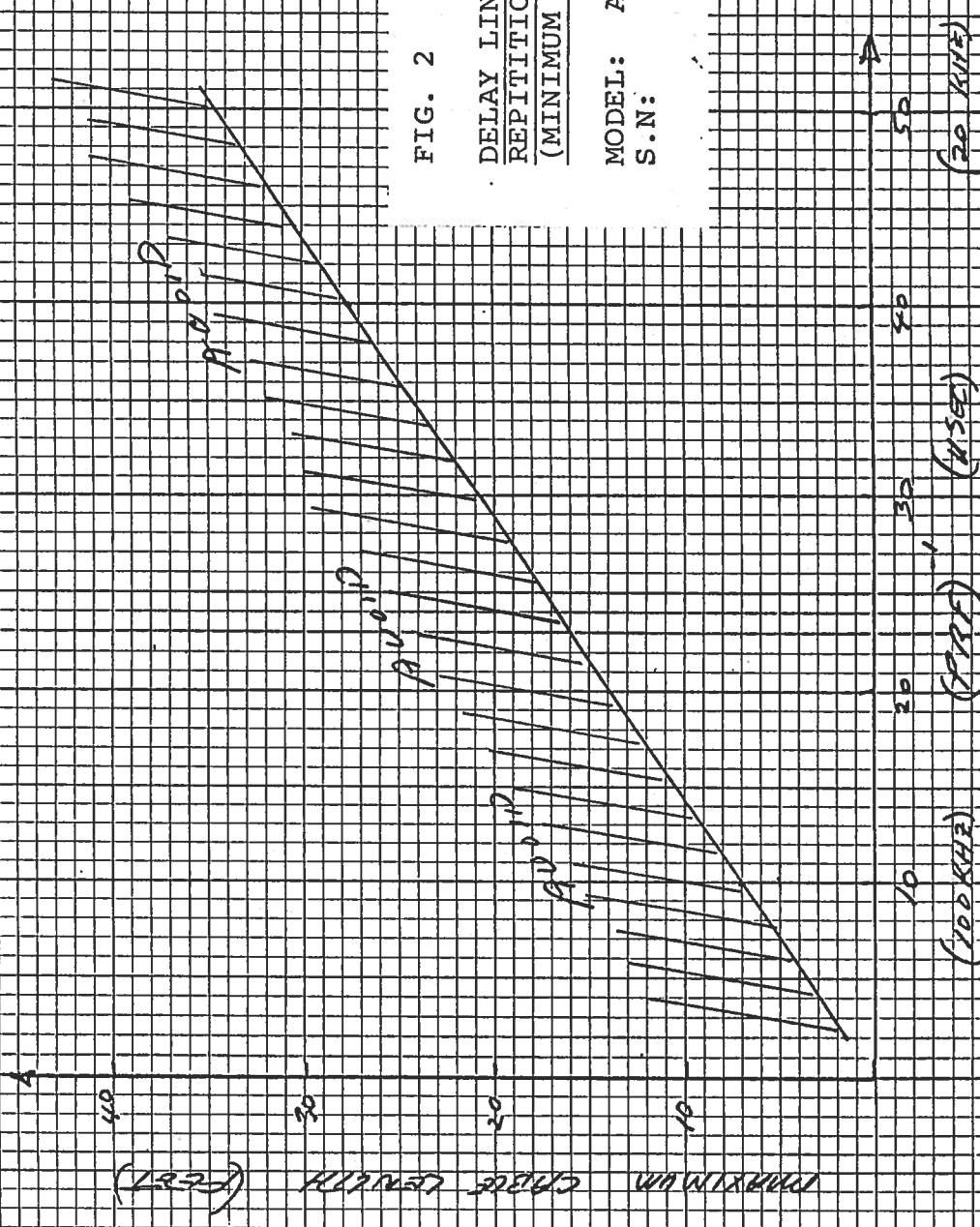
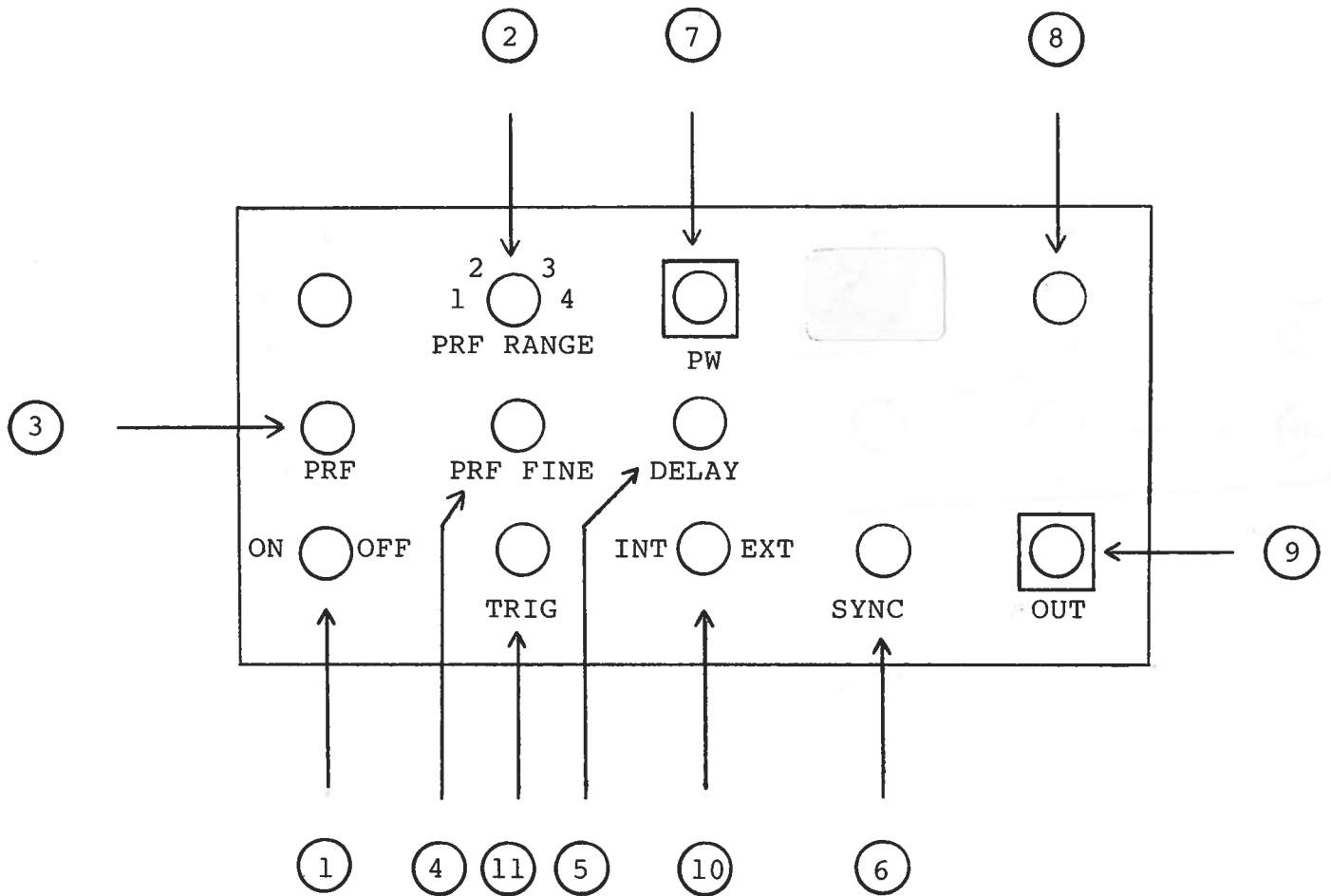

FIG. 2

DELAY LINE CABLE LENGTH VS PULSE  
REPETITION FREQUENCY PERIOD  
(MINIMUM ALLOWABLE PERIOD)

MODEL: AVK-A  
S.N:

FRONT PANEL CONTROLS





- (1) ON-OFF Switch. Applies basic prime power to all stages.
- (2) PRF Control. The PRF RANGE, PRF and PRF FINE controls
- (3) determine output PRF as follows:
- (4)

	PRF MIN	PRF MAX
Range 1	100 Hz	1 KHz
Range 2	1 KHz	10 KHz
Range 3	10 KHz	100 KHz
Range 4	100 KHz	1 MHz

- (4) PRF FINE Control. This control varies PRF but is about 10 times less sensitive than the main PRF control.
- (5) DELAY Control. Controls the relative delay between the reference output pulse provided at the SYNC output (6) the main output (9). This delay is variable over the range of 0 to at least 500 nsec.
- (6) SYNC Output. This output precedes the main output (9) and is used to trigger the sampling scope time base. The output is a TTL level 100 nsec (approx.) pulse capable of driving a fifty ohm load.
- (7) PW Control. SMA connector to which delay line is added to vary output PW. (see Fig. 1 and Fig. 2).
- (8) AMP Control. A one turn control which varies the output pulse amplitude from 0 to rated output to a fifty ohm load.
- (9) OUT Connector. SMA connector provides output to a fifty ohm load.
- (10) EXT-INT Control. With this toggle switch in the INT position, the PRF of the AVK unit is controlled via an internal clock which in turn is controlled by the PRF and PRF FINE controls. With the toggle switch in the EXT position, the AVK unit requires a 0.2 usec TTL level pulse applied at the TRIG input in order to trigger the output stages. In addition, in this mode, the scope time base must be triggered by the external trigger source.
- (11) TRIG Input. The external trigger signal is applied at this input when the EXT-INT toggle switch is in the EXT position.

Fig. 4

BACK PANEL CONTROLS

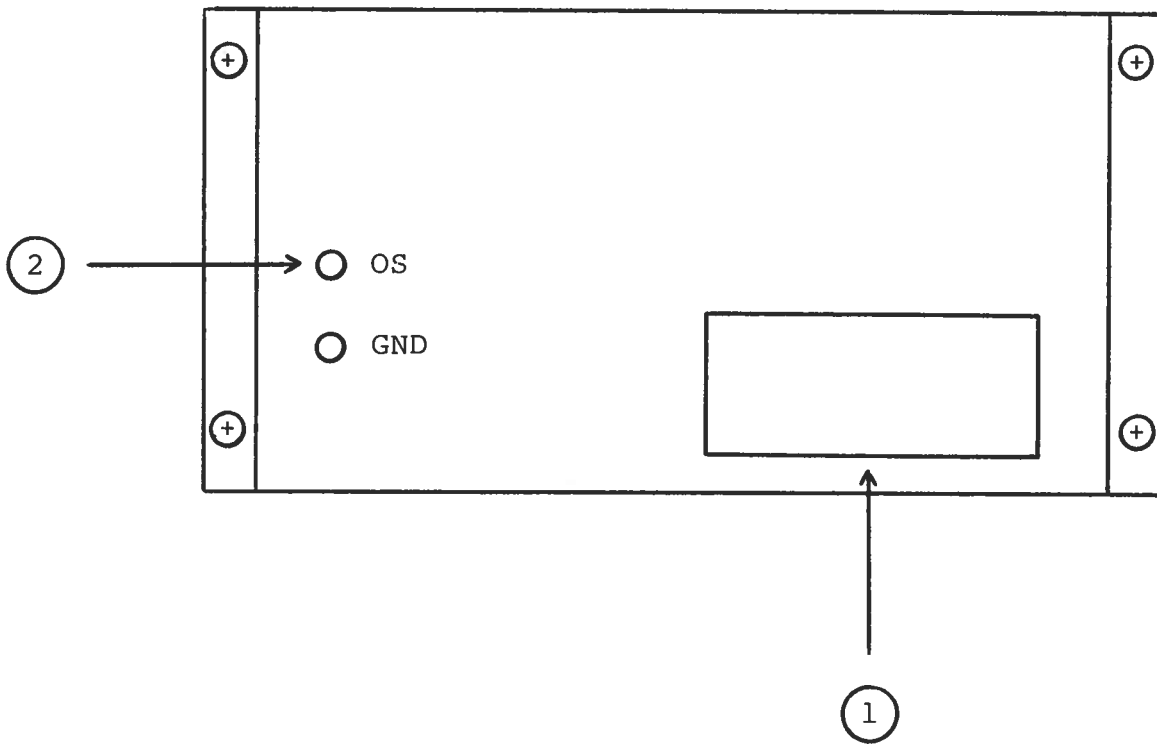

- (1) FUSED CONNECTOR, VOLTAGE SELECTOR. The detachable power cord is connected at this point. In addition, the removable cord is adjusted to select the desired input operating voltage. The unit also contains the main power fuse.
  
- (2) DC OFFSET Input. To DC offset the output pulse, connect a DC power supply set to the desired offset value to these terminals. The maximum allowable DC offset voltage is ±50 volts (option).

Fig. 4

SYSTEM BLOCK DIAGRAM

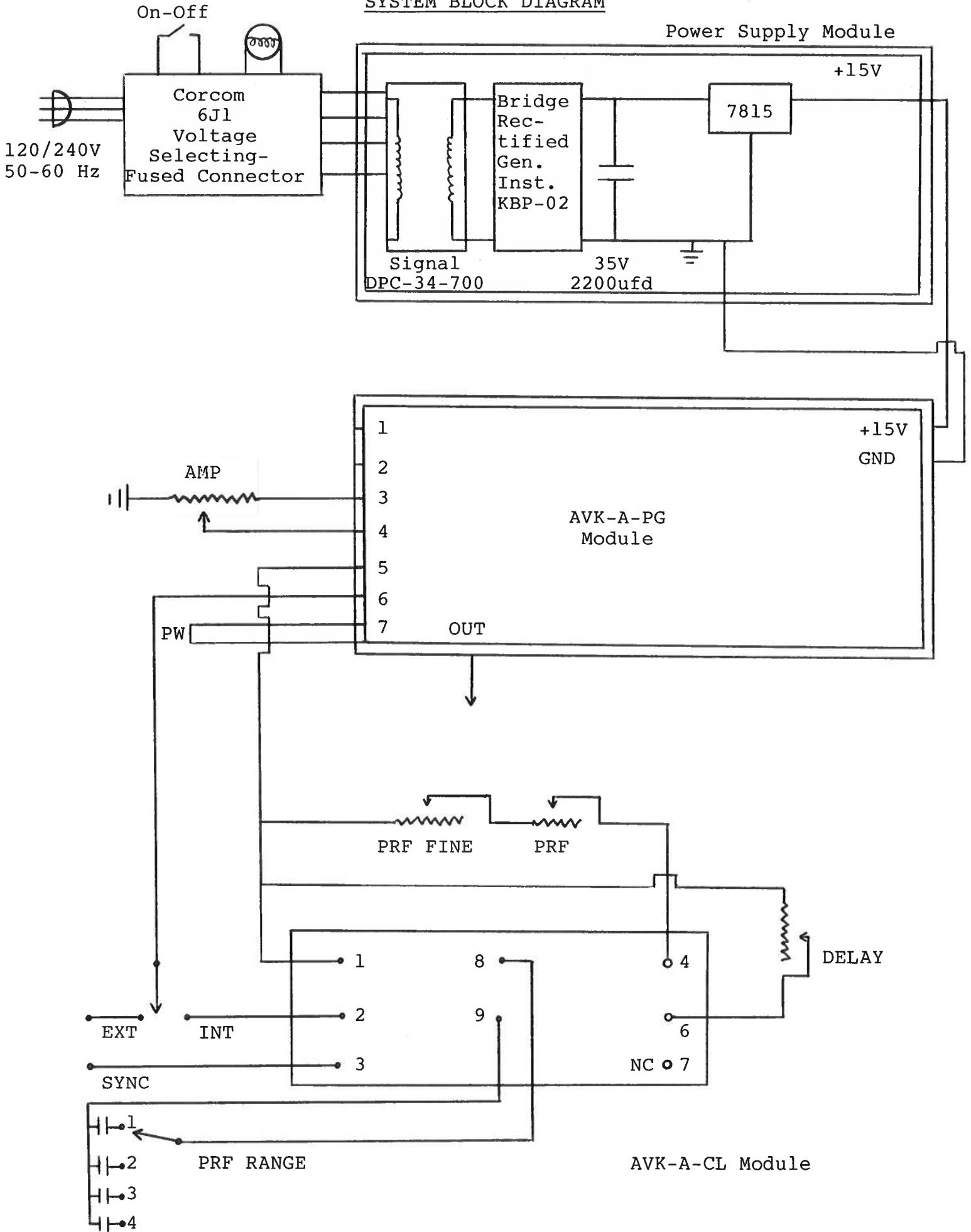

## SYSTEM DESCRIPTION AND REPAIR PROCEDURE

The AVK-A-C consists of a pulse generator module (AVK-A-PG), a clock module AVK-A-CL and a power supply board which supplies +15 volts (600 mA max) to the pulse generator module. In the event that the unit malfunctions, remove the instrument cover by removing the four Phillips screws on the back of the unit. The top cover may then be slid back. Measure the voltage at the +15 V pin of the PG module. If this voltage is substantially less than +15 volts, unsolder the line connecting the power supply and PG modules and connect 50 ohm 10 W load to the PS output. The voltage across this load should be about +15 V DC. If this voltage is substantially less than 15 volts the PS module is defective and should be repaired or replaced. If the voltage across the resistor is near 15 volts, then the PG module should be replaced or repaired. The sealed PG module must be returned to Avtech for repair (or replacement). The clock module provides a 0.1 usec TTL level trigger pulse at Pin 2 to trigger the PG module and a 0.1 usec TTL level synch pulse at Pin 3 to trigger the sampling scope display device. The output at Pin 3 precedes the output at Pin 2 by almost 0 to 100 nsec depending on the DELAY control setting. The clock module is powered by +5.8 V supplied by the PG module (from Pin 5 to Pin 1). With the INT-EXT switch in the EXT position, the clock module is disconnected from the PG module. The clock module is functioning properly if:

- a) 0.1 usec TTL level outputs are observed at pins 2 and 3.
- b) The PRF of the outputs can be varied over the range of 1 KHz to 1 MHz using the PRF, PRF FINE and PRF RANGE controls.
- c) The relative delay between the Pin 2 and 3 outputs can be varied by at least 100 nsec by the DELAY control.

The sealed clock module must be returned to Avtech for repair or replacement if the above conditions are not observed.

