

# AVTECH ELECTROSYSTEMS LTD.

NANOSECOND WAVEFORM ELECTRONICS  
ENGINEERING . MANUFACTURING

□ P.O. BOX 265  
OGDENSBURG  
NEW YORK  
13669  
(315) 472-5270

BOX 5120 STN. "F"  
OTTAWA, ONTARIO  
CANADA K2C 3H4  
(613) 226-5772  
TELEX 053-4591

## INSTRUCTIONS

MODEL AVK-AV-PS PULSE GENERATOR

S.N.:

### WARRANTY

Avtech Electrosystems Ltd. warrants products of its manufacture to be free from defects in material and workmanship under conditions of normal use. If, within one year after delivery to the original owner, and after prepaid return by the original owner, this Avtech product is found to be defective, Avtech shall at its option repair or replace said defective item. This warranty does not apply to units which have been disassembled, modified or subjected to conditions exceeding the applicable specifications or ratings. This warranty is the extent of the obligation or liability assumed by Avtech with respect to this product and no other warranty or guarantee is either expressed or implied.

MODEL AVK-AV-PS PULSE GENERATOR TEST ARRANGEMENT

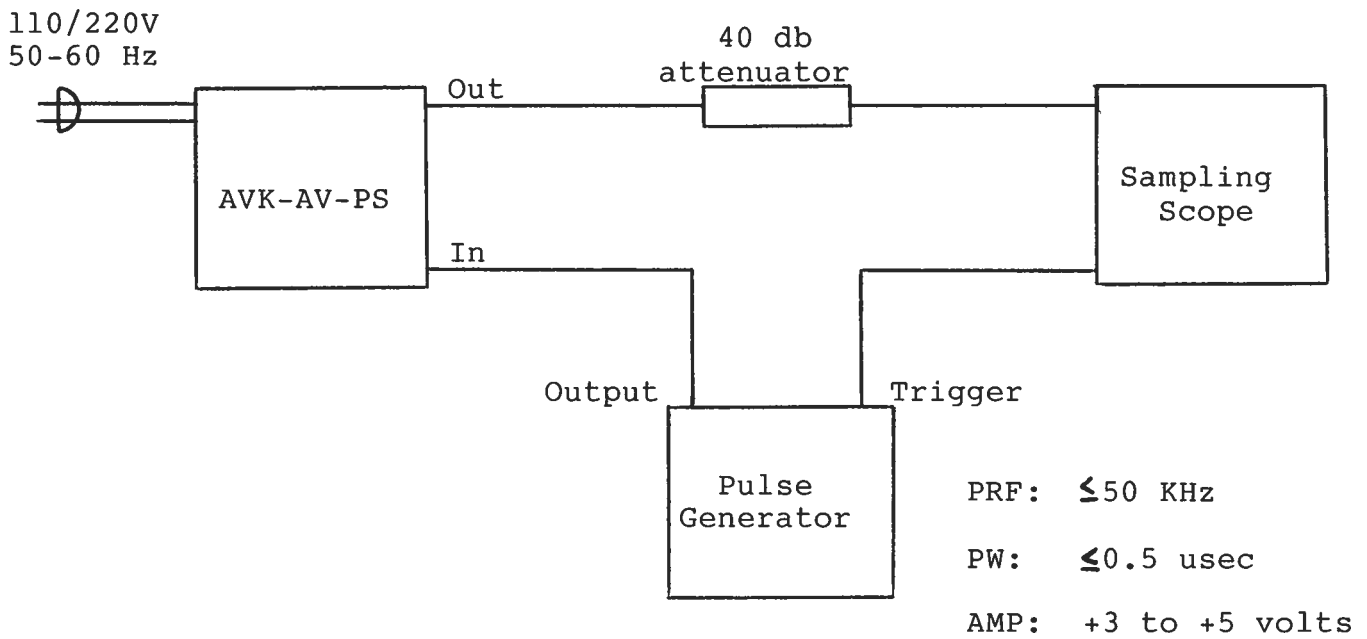

Notes:

- 1) The bandwidth capability of components and instruments used to display the pulse generator output signal (attenuators, cables, connectors, etc.) should exceed ten gigahertz.
- 2) The use of 40 db attenuator will insure a peak input signal to the sampling scope of less than one volt.
- 3) In general, the source pulse generator trigger delay control should be set in the 0.1 to 1.0 usec range. Other settings should be as shown in the above diagram.
- 4) The Model AVK-AV pulse generator can withstand an infinite VSWR on the output port.
- 5) WARNING: Model AVK-AV may fail if triggered at a PRF greater than 50 KHz.
- 6) The output pulse width is controlled by means of the one-turn potentiometer (PW). The pot should initially be set mid-range and the pulse width adjusted using an oscilloscope.
- 7) The output amplitude is controlled by means of the one-turn potentiometer (AMP). The pulse width may change by several nanoseconds as the output amplitude is reduced from maximum to minimum. Therefore it is convenient to first set the desired amplitude and then set the desired pulse width.
- 8) Some properties of the output pulse may change as a function of the amplitude pot setting. For some demanding applications, it may be desirable to use a combination of external attenuators and the amplitude pot to achieve the desired output amplitude.
- 9) To DC offset the output pulse connect a DC power supply set to the required DC offset value to the terminals marked O.S. The maximum attainable DC offset voltage is  $\pm 50$  volts (option).
- 10) For units with the dual output polarity option (-PN) a positive output pulse is obtained at the OUT P SMA connector. To obtain a negative output pulse, the OUT P port is connected to the IN N port via a short length of miniature 50 ohm coaxial cable. A negative output pulse is then obtained at the OUT N port.

SYSTEM BLOCK DIAGRAM

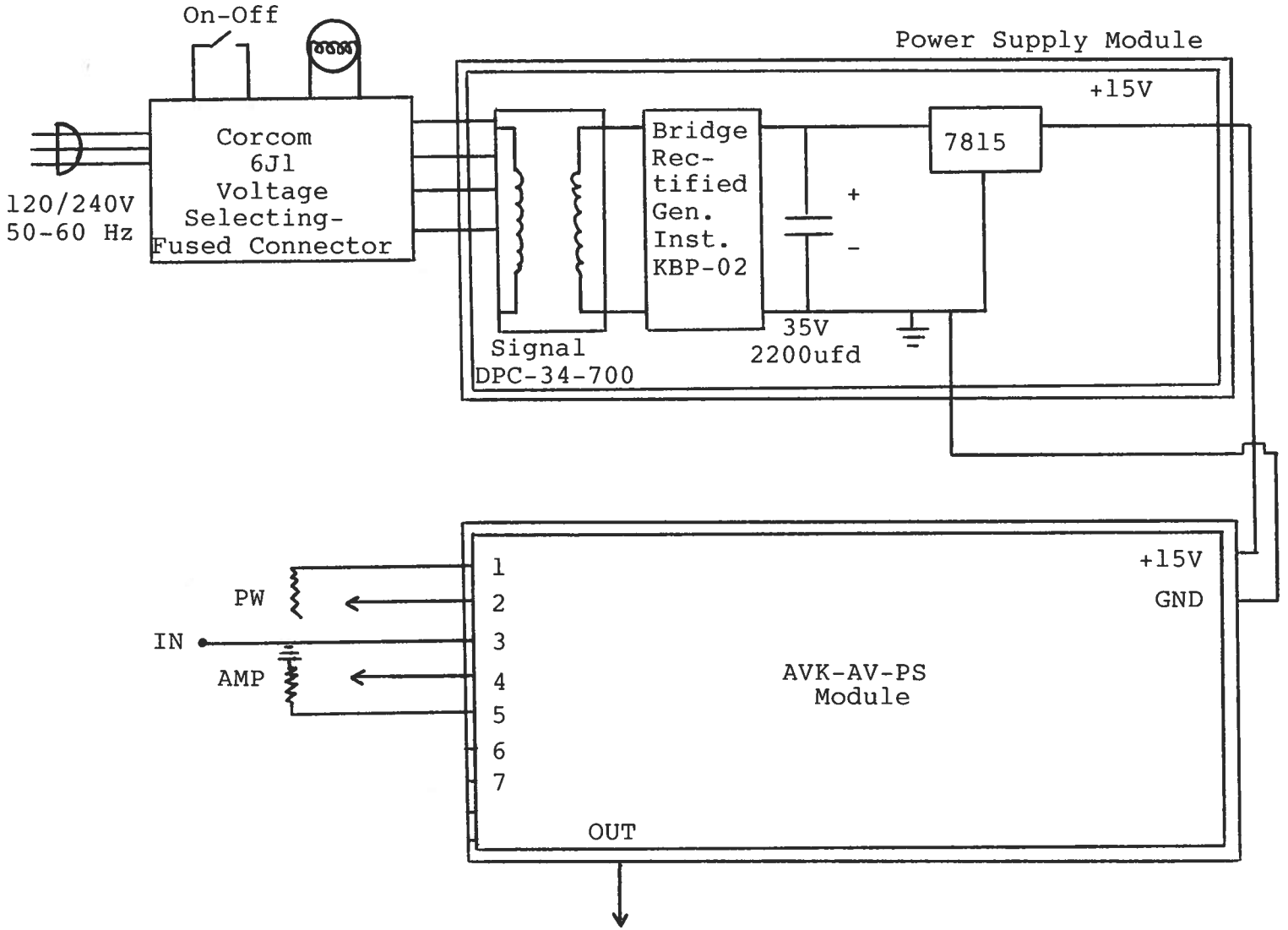

## SYSTEM DESCRIPTION AND REPAIR PROCEDURE

The AVK-AV-PS consists of a pulse generator module (AVK-AV-PG) and a power supply board which supplies +15 volts (600 mA max) to the pulse generator module. In the event that the unit malfunctions, remove the four Phillips screws on the back of the unit. The top cover may then be slid off. Measure the voltage at the +15 V pin of the PG module. If this voltage is substantially less than +15 volts, unsolder the line connecting the power supply and PG modules and connect 50 ohm 10 W load to the PS output. The voltage across this load should be about +15 V DC. If this voltage is substantially less than 15 volts the PS module is defective and should be repaired or replaced. If the voltage across the resistor is near 15 volts, then the PG module should be replaced or repaired. The sealed PG module must be returned to Avtech for repair (or replacement).

Schoff

-PN

-OS

STANDARD TIME IN THE EAST

The following information is for your information only. It is not intended to be used as a basis for any action. The information is based on the best available information at the time it was prepared. It is subject to change without notice. The information is for your information only. It is not intended to be used as a basis for any action. The information is based on the best available information at the time it was prepared. It is subject to change without notice. The information is for your information only. It is not intended to be used as a basis for any action. The information is based on the best available information at the time it was prepared. It is subject to change without notice.