

AVTECH ELECTROSYSTEMS LTD.

**NANOSECOND WAVEFORM ELECTRONICS
ENGINEERING - MANUFACTURING**

□ P.O. BOX 265
OGDENSBURG
NEW YORK
13669
(315) 472-5270

✕ BOX 5120 STN. "F"
OTTAWA, ONTARIO
CANADA K2C 3H4
(613) 226-5772
TELEX 053-4591

INSTRUCTIONS

MODEL AVL-2-PS-TN-MHV-DC1 PULSE GENERATOR

S.N.:

WARRANTY

Avtech Electrosystems Ltd. warrants products of its manufacture to be free from defects in material and workmanship under conditions of normal use. If, within one year after delivery to the original owner, and after prepaid return by the original owner, this Avtech product is found to be defective, Avtech shall at its option repair or replace said defective item. This warranty does not apply to units which have been disassembled, modified or subjected to conditions exceeding the applicable specifications or ratings. This warranty is the extent of the obligation or liability assumed by Avtech with respect to this product and no other warranty or guarantee is either expressed or implied.

MODEL AVL-2-PS PULSE GENERATOR TEST ARRANGEMENT

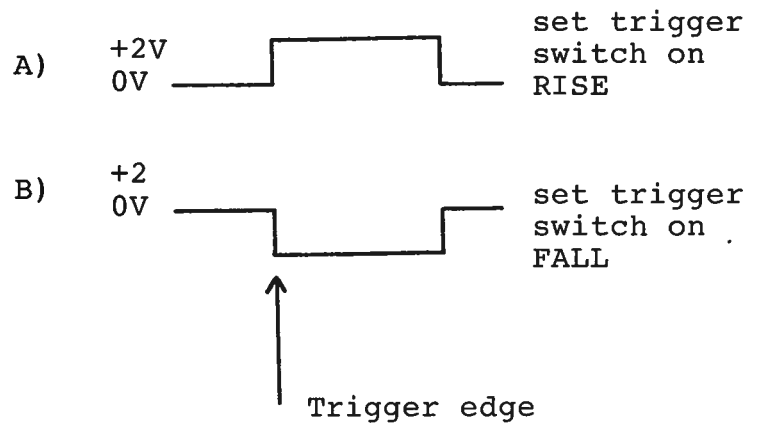
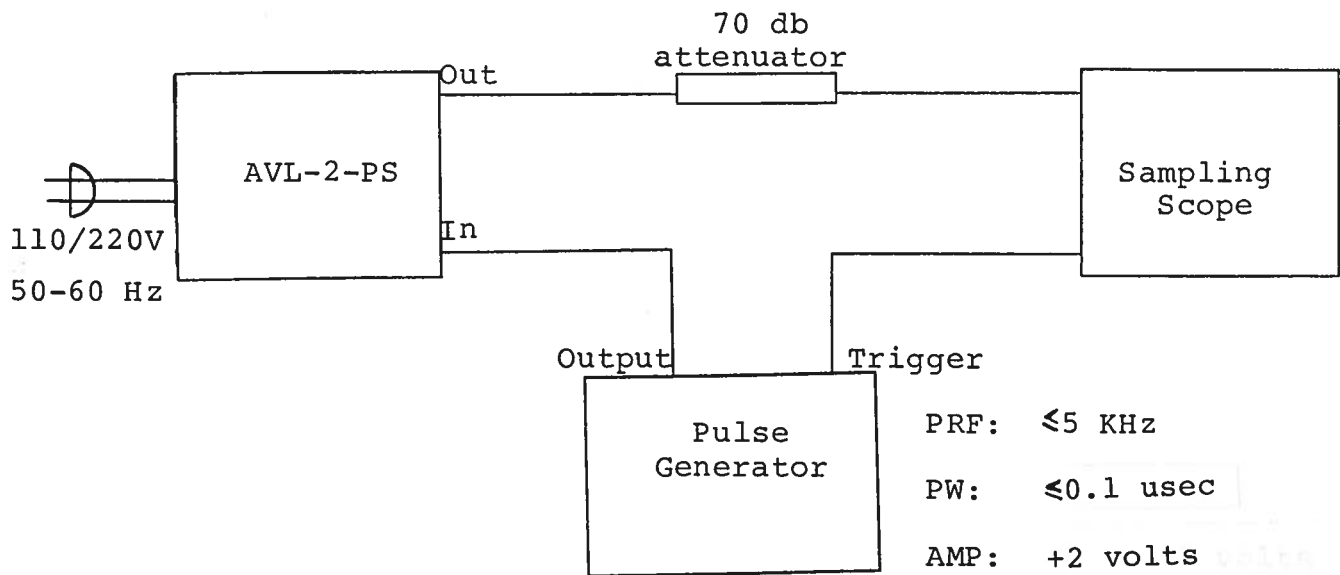

GENERAL OPERATING INSTRUCTIONS

- 1) The bandwidth capability of components and instruments used to display the pulse generator output signal (attenuators, cables, connectors, etc.) should exceed 1.0 GHz.
- 2) The use of a 70 db attenuator will insure a peak input signal to the sampling scope of less than one volt. **WARNING:** Model AVL-2 may provide a peak power output in excess of 2.8 KW. The peak power rating of the attenuator must exceed this limit.
- 3) The unit triggers on the leading edge of a 2 volt input pulse (see waveforms A or B on preceding block diagram). For waveform A, the trigger switch on the front panel should be set on the RISE position, while for waveform B, the trigger switch should be set on the FALL position (-DC1 option). The propagation delay through the AVL-2-PS unit is fixed at 110 nsec (-TN option). The DC1 option increases the propagation delay by 10 nsec (approx).
- 4) In general, the source pulse generator trigger delay control should be set in the 0.1 to 1.0 usec range. Other settings should be as shown in the above diagram.
- 5) The Model AVL-2 pulse generator can withstand an infinite VSWR on the output port.
- 6) **WARNING:** Model AVL-2 may fail if triggered at a PRF greater than 5 KHz.
- 7) The output pulse width is controlled by means of the one turn potentiometer (PW). The pot should initially be set mid-range and the pulse width adjusted using an oscilloscope. The output will degenerate to an impulse and eventually vanish as the pot is turned fully counter clockwise.
- 8) The output pulse amplitude is controlled by means of the one turn potentiometer (AMP) and the HIGH-LOW switch adjacent to the AMP control. With the switch in the HIGH position, the output amplitude is variable over the range of 75 to 350 volts while in the LOW position the output amplitude is variable over the range of about 0 to 300 volts.
- 9) Some properties of the output pulse may change as a function of the amplitude pot setting. For some demanding applications, it may be desirable to use a combination of external attenuators and the amplitude pot to achieve the desired output amplitude.

- 10) OUTPUT POLARITY CONTROL (Option). With the back panel switch in the (P) position, the output is positive. With the switch set in the (N) position, the output pulse is negative.
- 11) MONITOR Output. The back panel monitor output provides an attenuated replica (20 db down) of the output less DC offset. The monitor output is designed to operate into a 50 ohm load. (option).
- 12) DC Offset (OS). The desired DC offset is applied to the back panel OS terminals which are connected to the output centre conductor via a high quality RF inductor. Do not exceed $\pm 100V$, 0.1 amp. (option).
- 13) RISE TIME CONTROL (Option). Varies rise and fall times in one nanosecond increments from about one to ten nanoseconds.
- 14) NOTE: The lifetime of the switching elements in the pulse generator module is proportional to the running time of the instrument. For this reason the prime power to the instrument should be turned off when the instrument is not in use. In the case of failure, the switching elements are easily replaced following the procedure described in the following section.

Fig. 3

BACK PANEL CONTROLS

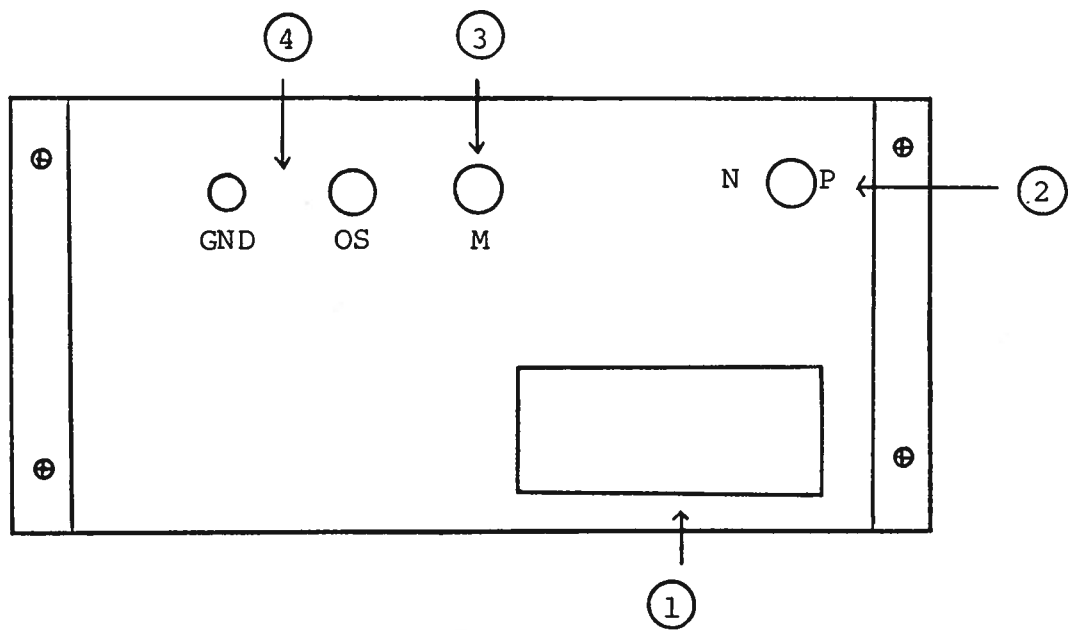

- (1) FUSED CONNECTOR, VOLTAGE SELECTOR. The detachable power cord is connected at this point. In addition, the removable cord is adjusted to select the desired input operating voltage. The unit also contains the main power fuse.
- (2) OUTPUT POLARITY CONTROL (Option). With switch in (P) position, output is positive. With switch in (N) position, output pulse is negative.
- (3) MONITOR Output. The back monitor output provides an attenuated replica (20 db down) of the output less DC offset. The monitor output is designed to operate into a 50 ohm load. (option).
- (4) DC Offset (OS). The desired DC offset is applied to the back panel OS terminals which are connected to the output centre conductor via a high quality RF inductor. Do not exceed $\pm 100V$, 0.1 amp. (option).

REPAIR PROCEDURE

- 1) **WARNING:** Before attempting any repairs, note that potentials as high as 400 volts are employed in the chassis structure.
- 2) The pulse generator is constructed from the following basic subsystems or modules:
 - a) Metal chassis
 - b) Pulse generator module (AVL-2-PG)
 - c) Delay line module (AVL-2-DL)
 - d) Timing module (AVL-2-T)
 - e) Power supply module (AVL-2-PS)
 - f) Power supply board (+15V out)

The five modules are interconnected as shown in Fig. 1.

- 3) If no output pulse is provided by the AVL-2 unit, turn off the prime power supply and remove the top cover panel by removing the four Phillips screws on the back panel of the instrument. The top cover may then be slid off. Apply a scope probe or voltmeter to pin 1 of the AVL-2-PS unit. Turn on the prime power supply. A voltage of about 360 to 380 volts should be read at pin 1. If the voltage is zero or much less than 380 volts, then one of the switching transistors (Part No. SL3) in the AVL-2-PG module has probably failed. To access the switching transistors, remove the three 2-56 screws which secure the black cover plate on the back panel of the pulse generator. **WARNING:** The cases of the transistors are at potentials as high as 380 volts. With the prime power supply off remove one of the transistors by removing the two 2-56 screws which secure the transistor in its socket. Pull the transistor out of the socket. With the unit un-triggered turn on the prime power supply and measure the voltage from the case of the remaining transistor to ground. If the voltage is about 360 to 380 volts then the transistor which was removed is defective and should be replaced. If the voltage which is measured is less than 360 volts then the transistor still in position is defective and should be replaced. Note that the two transistors are completely interchangeable (Order Avtech Part No. SL3). Note that with both transistors removed, the voltage at pin 1 on the AVL-2-PS module should be in the range of 360 to 380 volts. If the voltage is less than the AVL-2-PS module must be replaced.

If both the AVL-2-PS module and the AVL-2-PG module are not found to be defective then the AVL-2-T module is suspect. Connect one scope probe to pin 3 of the -T module and a second probe to pin 2 of the -T module. With the scope triggered externally by the pulse generator providing the trigger input signal to the AVL unit, the waveform at pins 2 and 3 of the -T module should resemble:

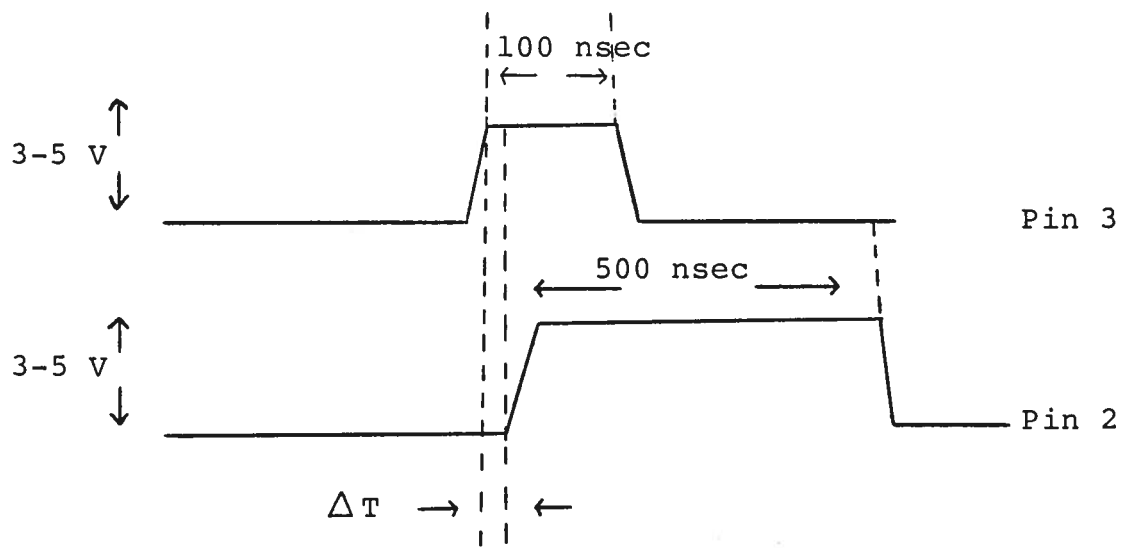

As the PW pot is varied over its full range ΔT should vary from about 0 to approximately 100 nsec. If the waveforms at pins 2 and 3 do not resemble the above, then the -T module is defective and should be replaced. If the waveforms do resemble the above then the -PG module is at fault and should be replaced.

Replacement modules should be ordered by part No. (eg. AVL-2-PG) from Avtech.

Fig. 1 System Block Diagram With Wiring And Pin Connections

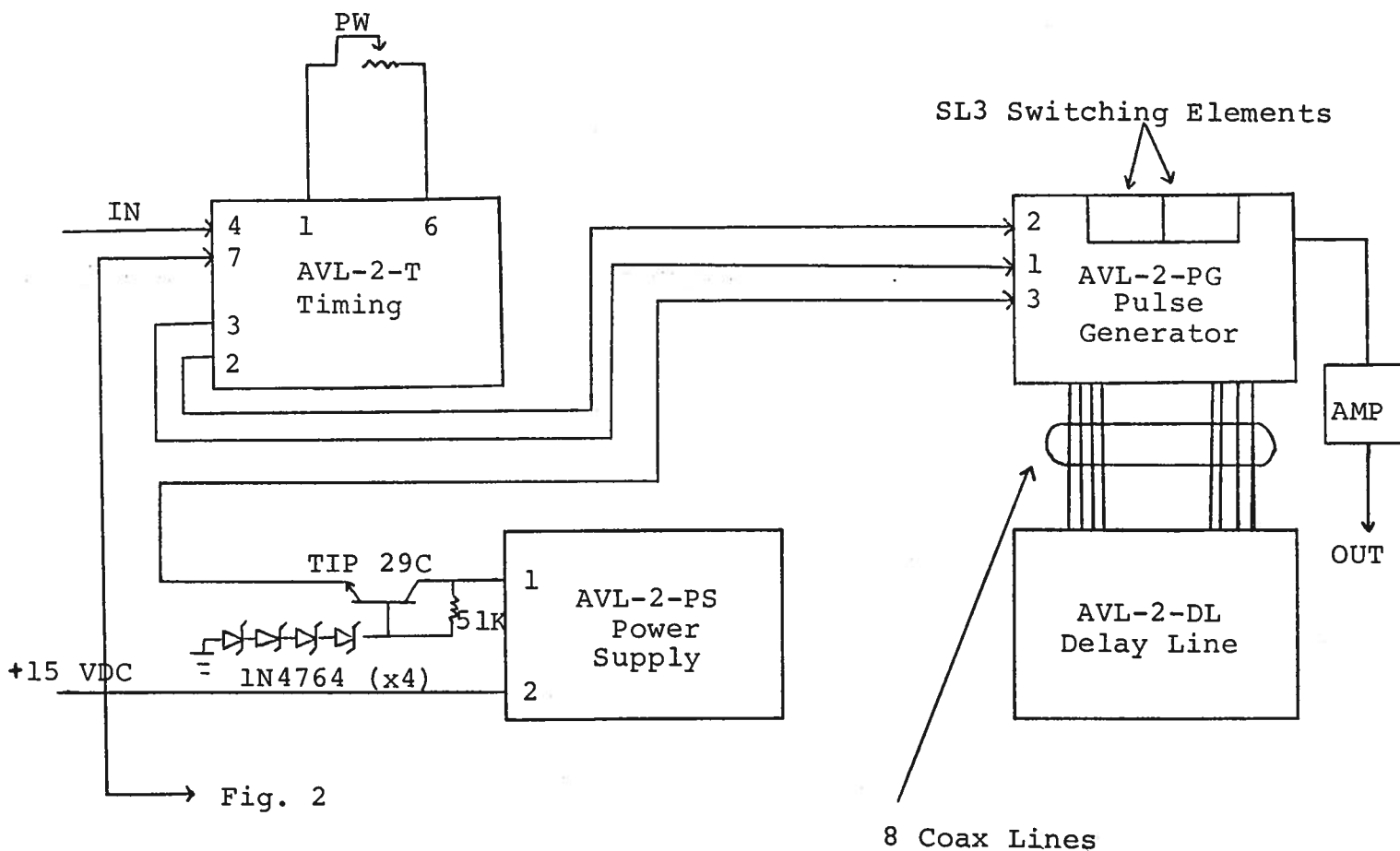

Note:

- 1) All interconnect lines are ribbon cable.
- 2) All module chassis are grounded to main chassis and to each other via separate ground lines.
- 3) **WARNING:** The line connecting pin 1 of AVL-2-PS to pin 3 of AVL-2-PG is at a potential of 380 to 400 volts.

LINE POWERED AVL-2 SYSTEM DESCRIPTION AND REPAIR PROCEDURE

The AVL-2-PS consists of the four standard modules and a power supply board which supplies +15 volts (600 mA max) to the pulse generator modules. In the event that the AVL-2-PS unit malfunctions, remove the instrument cover by removing the four Phillips screws on the back of the instrument. The top cover may then be slid off. Measure the voltage at the +15 V pin of the PS module. If this voltage is substantially less than +15 volts, unsolder the line connecting the power supply board output and connect a 50 ohm 10 W load to the power supply output. The voltage across this load should be about 15 V DC. If this voltage is substantially less than 15 volts the power supply board is defective and should be repaired or replaced. If the voltage is near +15V then see instructions in preceding section.

Fig. 2

POWER SUPPLY BOARD

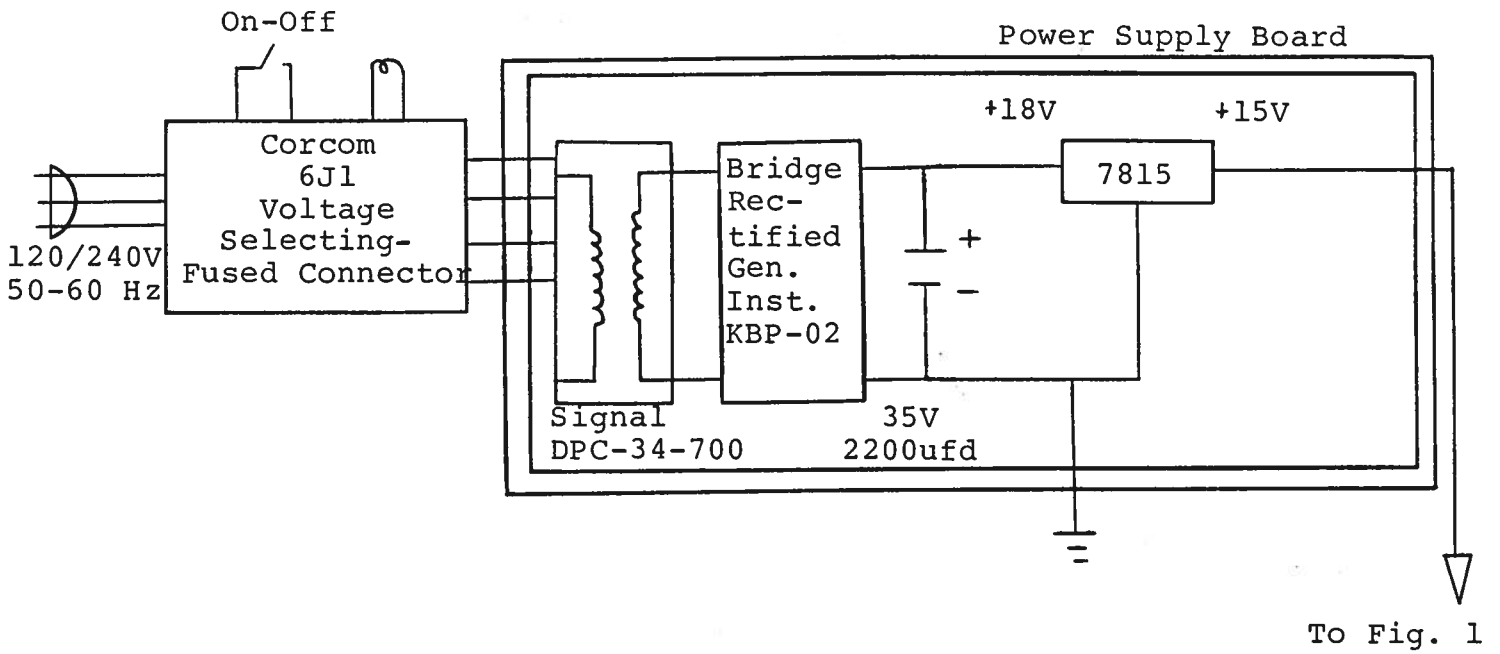

Schroff 05.31.88

- PN

- M

- OS