



# AVTECH ELECTROSYSTEMS LTD.

NANOSECOND WAVEFORM ELECTRONICS  
SINCE 1975

□ P.O. BOX 265  
OGDENSBURG, NY  
U.S.A. 13669-0265  
TEL: (315) 472-5270  
FAX: (613) 226-2802

TEL: 1-800-265-6681  
FAX: 1-800-561-1970

e-mail: [info@avtechpulse.com](mailto:info@avtechpulse.com)  
<http://www.avtechpulse.com>

□ P.O. BOX 5120 STN. F  
OTTAWA, ONTARIO  
CANADA K2C 3H4  
TEL: (613) 226-5772  
FAX: (613) 226-2802

## INSTRUCTIONS

MODEL AVL-2A-PS-CM1 PULSE GENERATOR

S.N.:

### WARRANTY

Avtech Electrosystems Ltd. warrants products of its manufacture to be free from defects in material and workmanship under conditions of normal use. If, within one year after delivery to the original owner, and after prepaid return by the original owner, this Avtech product is found to be defective, Avtech shall at its option repair or replace said defective item. This warranty does not apply to units which have been disassembled, modified or subjected to conditions exceeding the applicable specifications or ratings. This warranty is the extent of the obligation assumed by Avtech with respect to this product and no other warranty or guarantee is either expressed or implied.

### TECHNICAL SUPPORT

Phone: 613-226-5772 or 1-800-265-6681

Fax: 613-226-2802 or 1-800-561-1970

E-mail: [info@avtechpulse.com](mailto:info@avtechpulse.com)

World Wide Web: <http://www.avtechpulse.com>

Fig. 1

PULSE GENERATOR TEST ARRANGEMENT

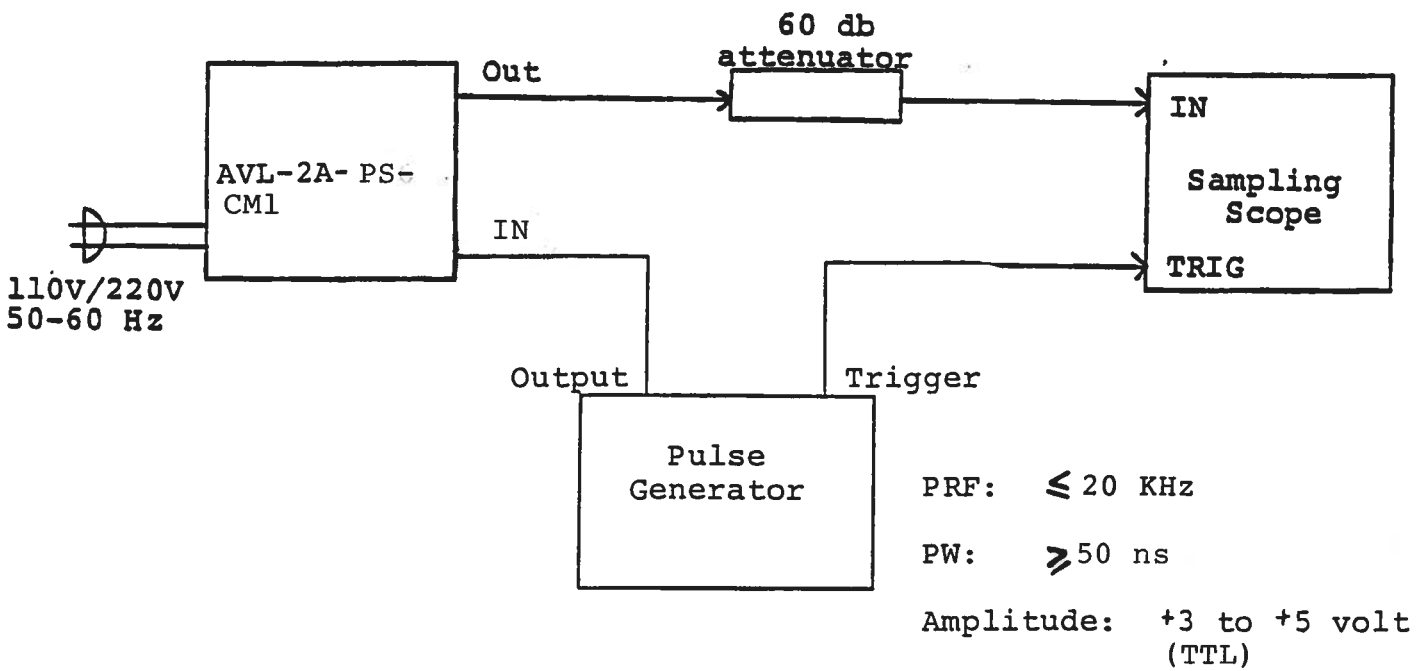

Notes:

- 1) The bandwidth capability of components and instruments used to display the pulse generator output signal (attenuators, cables, connectors, etc.) should exceed one gigahertz.
- 2) The use of 60 db attenuator at the sampling scope vertical input channel will insure a peak input signal to the sampling scope of less than one volt.
- 3) The output pulse width is controlled by means of the one turn potentiometer (PW). The pot should initially be set mid-range and the pulse width adjusted using an oscilloscope. The output will degenerate to an impulse and eventually vanish as the pot is turned fully counter clockwise. Units with the -W option are shipped with an 8 inch length of RG-58 cable connected between ports A and B on the back panel. This cable provides a maximum PW of about 100 nsec. The PW pot control is active over about 900 with this cable. The maximum PW may be extended up to 400 nsec by attaching RG-58 cable lengths of about 100 feet between ports A and B. With 100 feet of cable attached, the PW pot control is active over about 3000. The maximum attainable PW varies linearly with cable length for cable lengths between 6" and 100 feet. CAUTION: Insure that the input power is off before attempting to change the cable between ports A and B. Potentials as high as 400V exist on the centre conductor between ports A and B.
- 4) The output pulse amplitude is controlled by means of the one turn potentiometer (AMP) and the HIGH-LOW switch adjacent to the AMP control. With the switch in the HIGH position, the output amplitude is variable over the range of 75 to 170 volts while in the LOW position the output amplitude is variable over the range of about 0 to 150 volts.

- 5) The output amplitude may be controlled electronically by placing the rear panel EA switch in the ON position and applying 0 to +10 volts to the EA solder terminal. Note that the front panel manual amp control is still unctional when the EA switch is in the ON position (EA option).
- 6) Model AVL-2A can withstand an infinite VSWR on the output port but is intended for operation with 50 ohm loads.
- 7) NOTE: The lifetime of the switching elements in the pulse generator module is proportional to the running time of the instrument. For this reason the prime power to the instrument should be turned off when the instrument is not in use. In the case of failure, the switching elements are easily replaced following the procedure described in the following section.
- 8) The desired DC offset is applied to the back panel OS terminals which are connected to the output centre conductor via a high quality RF inductor. Do not exceed +100V, 0.1 amp. (option).
- 9) The back monitor output provides an attenuated replica (20 db down) of the output less DC offset. The monitor output is designed to operate into a 50 ohm load. (option).
- 10) The unit can be converted from 110 to 220V 50-60 Hz operation by adjusting voltage selector card in the rear panel fused voltage selector-cable connector assembly.
- 11) For additional assistance:

Tel: (613) 226-5772  
Fax: (613) 226-2802

Fig. 3

BACK PANEL CONTROLS

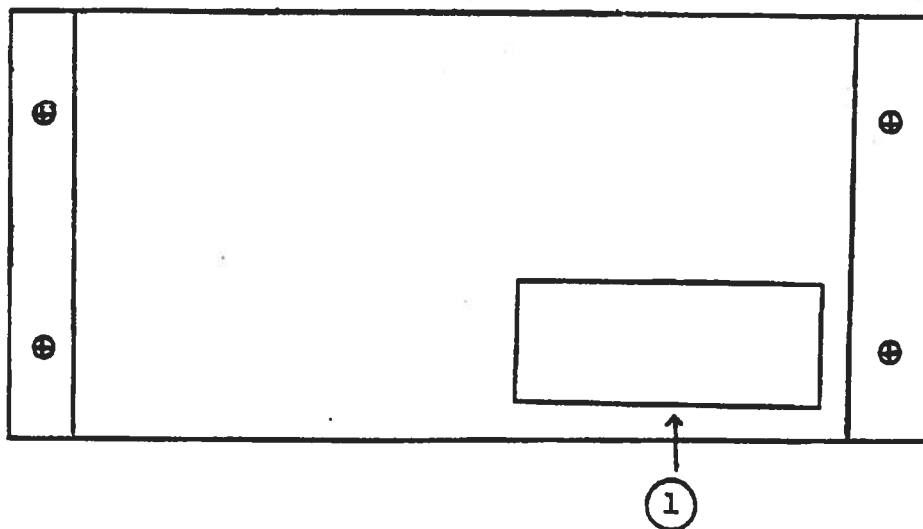

- (1) FUSED CONNECTOR, VOLTAGE SELECTOR. The detachable power cord is connected at this point. In addition, the removable cord is adjusted to select the desired input operating voltage. The unit also contains the main power fuse (0.25 A SB).

## REPAIR PROCEDURE

- 1) **WARNING:** Before attempting any repairs, note that potentials as high as 400 volts are employed in the chassis structure.
- 2) The pulse generator is constructed from the following basic subsystems or modules:
  - a) Metal chassis
  - b) Pulse generator module (AVL-2A-PG)
  - c) Power supply module (AVL-2A-PS)
  - d) Clock module (AVL-2A-CL)
  - e) Power supply board

The three modules are interconnected as shown in Fig. 1.

- 3) If no output pulse is provided by the AVL-2A unit, turn off the prime power supply and remove the top cover panel by removing the four Phillips screws on the back side of the instrument. The top cover will then slide out to expose the interior. Apply a scope probe or voltmeter to pin 6 of the AVL-2A-PG unit. Turn on the prime power supply. A voltage of about 360 to 380 volts should be read at pin 6. If the voltage is zero or much less than 380 volts, then one of the switching transistors (Part No. SL3) in the AVL-2A-PG module has probably failed. **WARNING:** The cases of the transistors are at potentials as high as 380 volts. With the prime power supply off remove one of the transistors by removing the two 2-56 screws which secure the transistor in its socket. Pull the transistor out of the socket. With the unit un-triggered turn on the prime power supply and measure the voltage from the case of the remaining transistor to ground. If the voltage is about 360 to 380 volts then the transistor which was removed is defective and should be replaced. If the voltage which is measured is less than 360 volts then the transistor still in position is defective and should be replaced. Note that the two transistors are completely interchangeable (Order Avtech Part No. SL3). Note that with both transistors removed, the voltage at pin 6 on the AVL-2A-PG module should be in the range of 360 to 380 volts. If the voltage is less then the AVL-2A-PS module must be replaced.



The AVL-2A-CL-CM1 module is functioning properly if:

- a) The TTL level output at pin 2 varies from 50 Hz to 20 KHz as the PRF control is varied.
- b) The relative delay between the output at pins 2 and 3 varies by about 100 to 200 nsec as the DELAY control is varied.

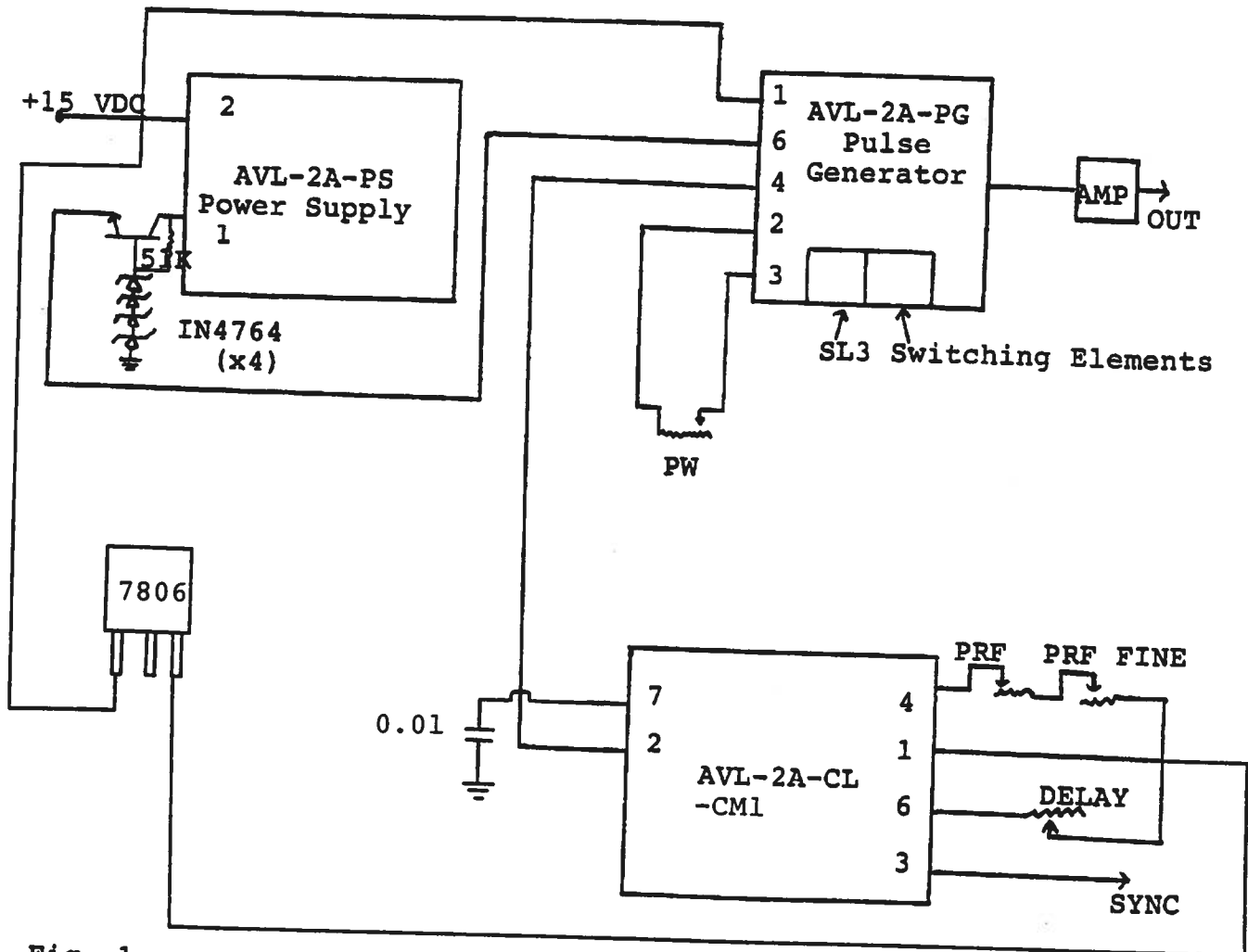

Fig. 1

Notes:

- 1) All module chassis are grounded to main chassis and to each other via separate ground lines.
- 2) **WARNING:** The line connecting pin 1 of AVL-2A-PS to pin 6 of AVL-2A-PG is a potential of 375 to 400 volts.

## LINE POWERED AVL-2A SYSTEM DESCRIPTION AND REPAIR PROCEDURE

The AVL-2A-C consists of the three standard modules and a power supply board which supplies +15 volts (600 mA max) to the pulse generator modules. In the event that the AVL-2A unit malfunctions, remove the instrument cover by removing the two screws on each side of the unit, thereby exposing the modules. Measure the voltage at the +15 V pin of the PG module. If this voltage is substantially less than +15 volts, unsolder the line connecting the power supply board and PG module and connect a 50 ohm 10 W load to the power supply output. The voltage across this load should be about 15 V DC. If this voltage is substantially less than 15 volts the power supply board is defective and should be repaired or replaced. If the voltage is near +15V then see instructions in preceding section.

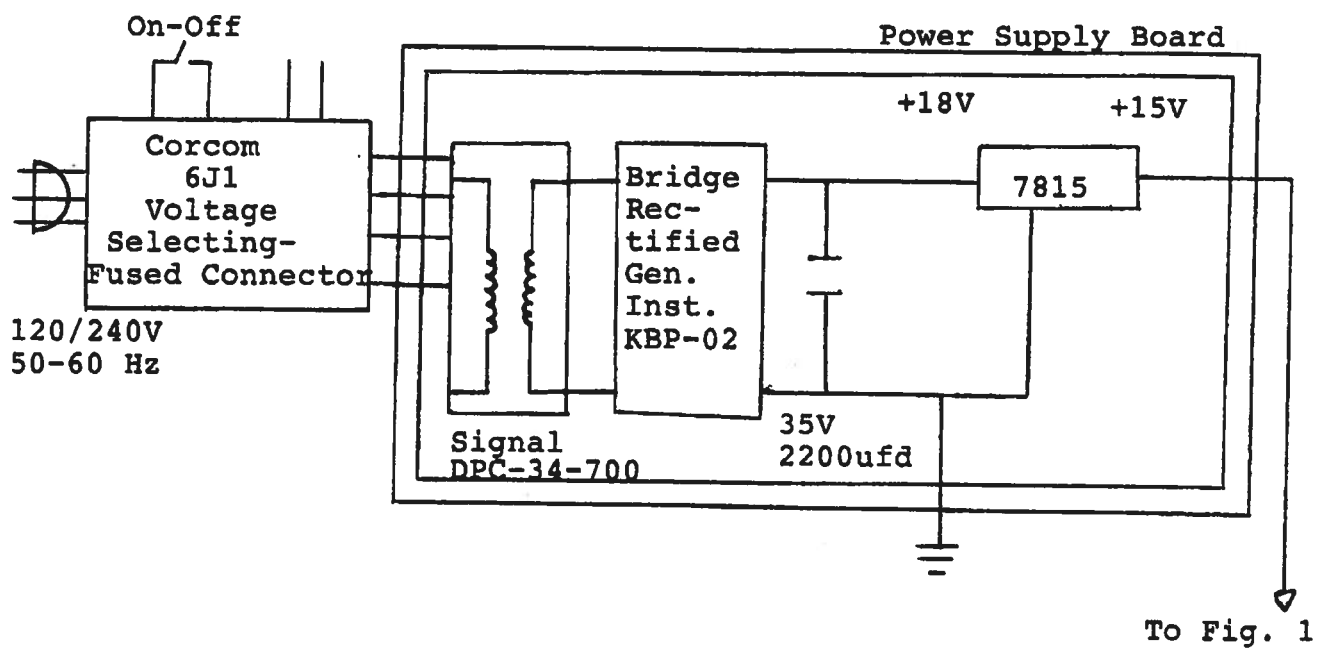

Aug 11/98

wpinstr /av/ZA / ZA-PS-CM1.INS. DOC