



# AVTECH ELECTROSYSTEMS LTD.

NANOSECOND WAVEFORM ELECTRONICS  
SINCE 1975

P.O. BOX 265  
OGDENSBURG, NY  
U.S.A. 13669-0265  
TEL: (315) 472-5270  
FAX: (613) 226-2802

TEL: 1-800-265-6681  
FAX: 1-800-561-1970  
U.S.A. & CANADA

e-mail: [info@avtechpulse.com](mailto:info@avtechpulse.com)

BOX 5120 STN. F  
OTTAWA, ONTARIO  
CANADA K2C 3H4  
TEL: (613) 226-5772  
FAX: (613) 226-2802

## INSTRUCTIONS

MODEL AVL-AV-1-PS PULSE GENERATOR

S.N. :

### WARRANTY

Avtech Electrosystems Ltd. warrants products of its manufacture to be free from defects in material and workmanship under conditions of normal use. If, within one year after delivery to the original owner, and after prepaid return by the original owner, this Avtech product is found to be defective, Avtech shall at its option repair or replace said defective item. This warranty does not apply to units which have been disassembled, modified or subjected to conditions exceeding the applicable specifications or ratings. This warranty is the extent of the obligation or liability assumed by Avtech with respect to this product and no other warranty or guarantee is either expressed or implied.

MODEL AVL-2A-PS PULSE GENERATOR TEST ARRANGEMENT

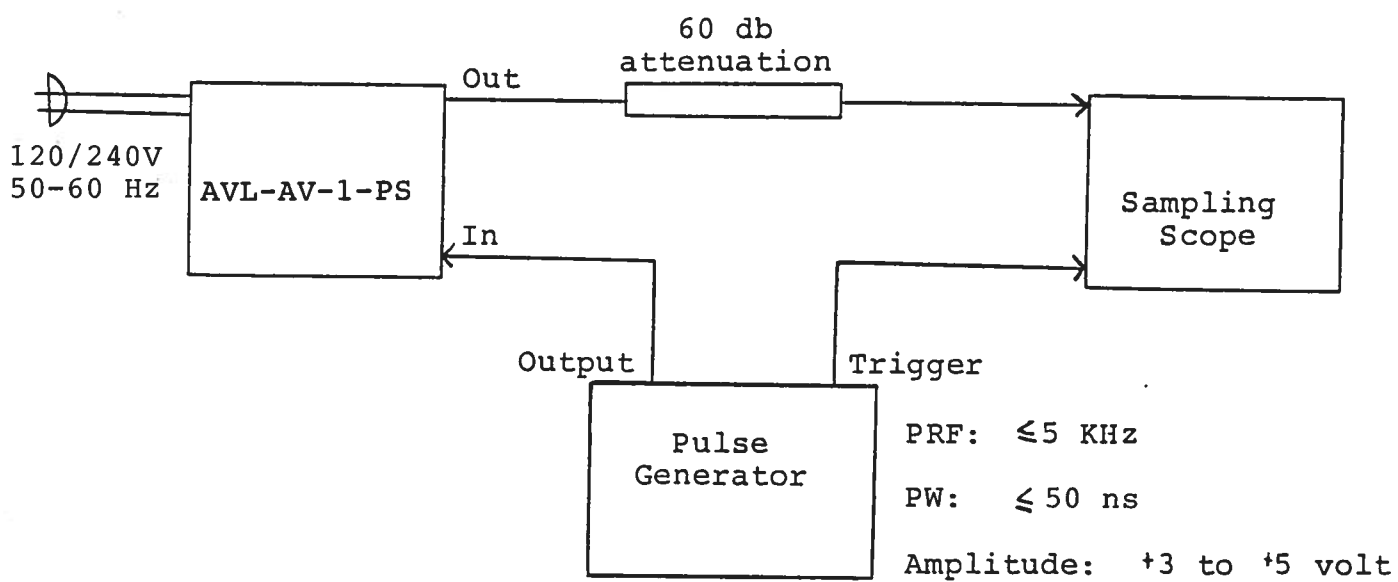

## GENERAL OPERATING INSTRUCTIONS

- 1) The bandwidth capability of components and instruments used to display the pulse generator output signal (attenuators, cables, connectors, etc.) should exceed 1000 MHz.
- 2) The use of a 60 dB attenuator will insure a peak input signal to the sampling scope of less than one Volt.
- 3) In general, the source pulse generator trigger delay control should be set in the 0.1 to 1.0 us range. Other settings should be as shown in the above diagram.
- 4) The Model AVL-AV-1 pulse generator can withstand an infinite VSWR on the output port.
- 5) WARNING: Model AVL-AV-1 may fail if triggered at a PRF greater than 5 kHz.
- 6) The output pulse width is controlled by means of the one turn potentiometer (PW). The pot should initially be set mid-range and the pulse width adjusted using an oscilloscope. The output will degenerate to an impulse and eventually vanish as the pot is turned fully counter clockwise.
- 7) The output pulse amplitude is controlled by means of the one turn potentiometer (AMP).
- 8) OUTPUT POLARITY CONTROL (Option). With the back panel switch in the (P) position, the output is positive. With the switch set in the (N) position, the output pulse is negative.
- 9) MONITOR Output. The back panel monitor output provides an attenuated replica (20 dB down) of the output less DC offset. The monitor output is designed to operate into a 50 Ohm load. (option).
- 10) DC Offset (OS). The desired DC offset is applied to the back panel OS terminals which are connected to the output centre conductor via a high quality RF inductor. Do not exceed  $\pm 50V$ , 0.1 Amp. (option).
- 11) RISE TIME CONTROL (Option). Varies rise and fall times in one nanosecond increments from about one to ten nanoseconds.

- 12) NOTE: The lifetime of the switching elements in the pulse generator module is proportional to the running time of the instrument. For this reason the prime power to the instrument should be turned off when the instrument is not in use. In the case of failure, the switching elements are easily replaced following the procedure described in the following section.
- 13) Model AVL-2 can withstand an infinite VSWR on the output port but is intended for operation with 50 Ohm loads.
- 14) The unit can be converted from 100 to 220V 50-60 Hz operation by adjusting the voltage selector card in the rear panel fused voltage selector-cable connector assembly.
- 15) For additional assistance:  
Tel: (613) 226-5772  
Fax: (613) 226-2802

BACK PANEL CONTROLS

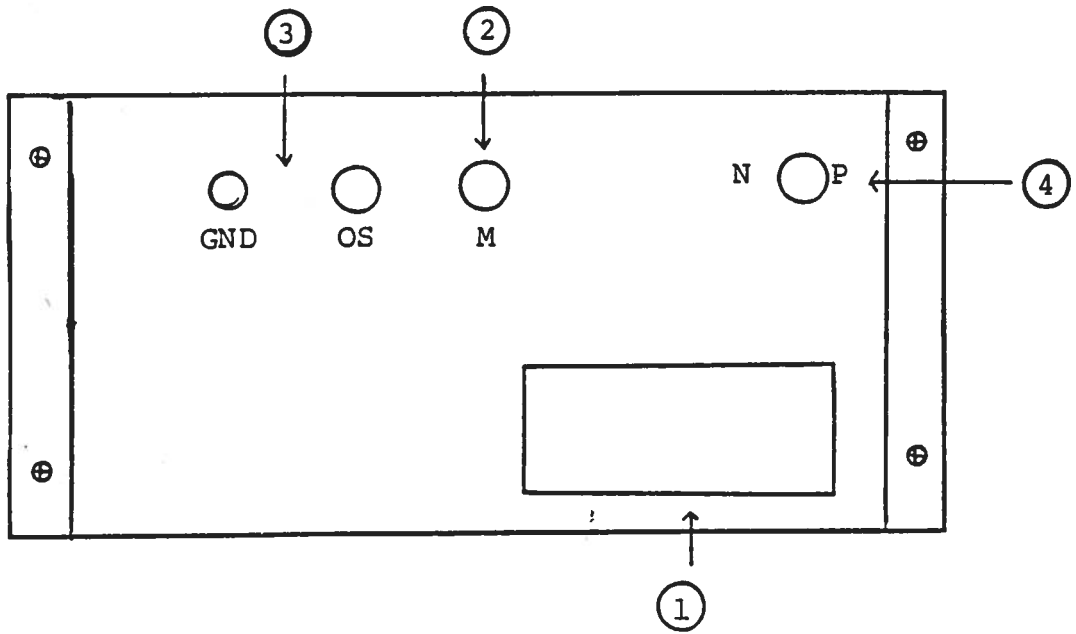

- (1) FUSED CONNECTOR, VOLTAGE SELECTOR. The detachable power cord is connected at this point. In addition, the removable cord is adjusted to select the desired input operating voltage. The unit also contains the main power fuse (0.25 Amp).
- (2) MONITOR Output. The back monitor output provides an attenuated replica (20 dB down) of the output less DC offset. The monitor output is designed to operate into a 50 Ohm load. (Option).
- (3) DC Offset (OS). The desired DC offset is applied to the back panel OS terminals which are connected to the output centre conductor via a high quality RF inductor. Do not exceed  $\pm 50V$ , 0.1 Amp. (Option).
- (4) OUTPUT POLARITY CONTROL (Option). With switch in (P) position, output is positive. With switch in (N) position, output pulse is negative.

## TOP COVER REMOVAL

To remove the top cover, remove the four Phillips screws on the top cover and then slide the cover back and off.



## REPAIR PROCEDURE

- 1) **WARNING:** Before attempting any repairs, note that potentials as high as 400 Volts are employed in the chassis structure.
  
- 2) The pulse generator is constructed from the following basic subsystems or modules:
  - a) Metal chassis
  - b) Pulse generator module (AVL-AV-1-PG)
  - c) Power supply module (AVL-2A-PS)
  - d) Power supply board

The two modules are interconnected as shown in Fig. 1.

- 3) If no output pulse is provided by the AVL unit, turn off the prime power supply and remove the top cover panel by removing the four Phillips screws on the back of the instrument. Apply a scope probe or voltmeter to pin 6 of the AVL-AV-PG unit. With the unit untriggered, turn on the prime power supply. A voltage of about 360 to 380 Volts should be read at pin 6. Alternatively, the voltage may be measured on the cases of the SL3 switching elements. If the voltage is zero or much less than 360 Volts, then one of the switching transistors (Part No. SL3) in the AVL-AV-PG module has probably failed. With the prime power supply off remove one of the transistors by removing the two 2-56 screws which secure the transistor in its socket.  
**CAUTION:** Before touching or removing the transistor, the cases should be briefly shorted to the instrument case to discharge charged capacitors (as high as 400 Volts). Pull the transistor out of the socket. With the unit untriggered turn on the prime power supply and measure the voltage from the case of the remaining transistor to ground. If this voltage is about 360 to 380 Volts then the transistor which was removed is defective and should be replaced. If the voltage which is measured is less than 360 Volts then the transistor still in position is defective and should be replaced. Note that the two transistors are completely interchangeable (Order Avtech Part No. SL3). Note that with both transistors removed, the voltage at pin 6 on the AVL-AV-PG module should be in the range of 360 to 380 Volts. If the voltage is less then the AVL-2-PS module must be replaced.

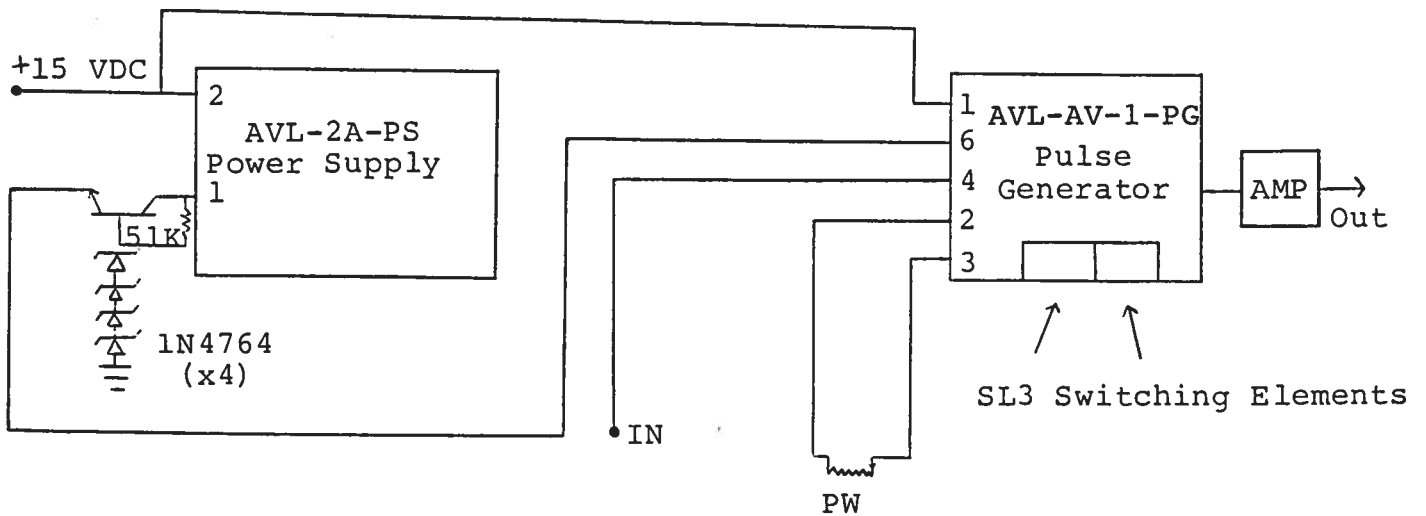

Notes:

- 1) All module chassis are grounded to main chassis and to each other via separate ground lines.
- 2) WARNING: The line connecting pin 1 of AVL-2A-PS to pin 6 of AVL-2A-PG is a potential of 375 to 400 volts.

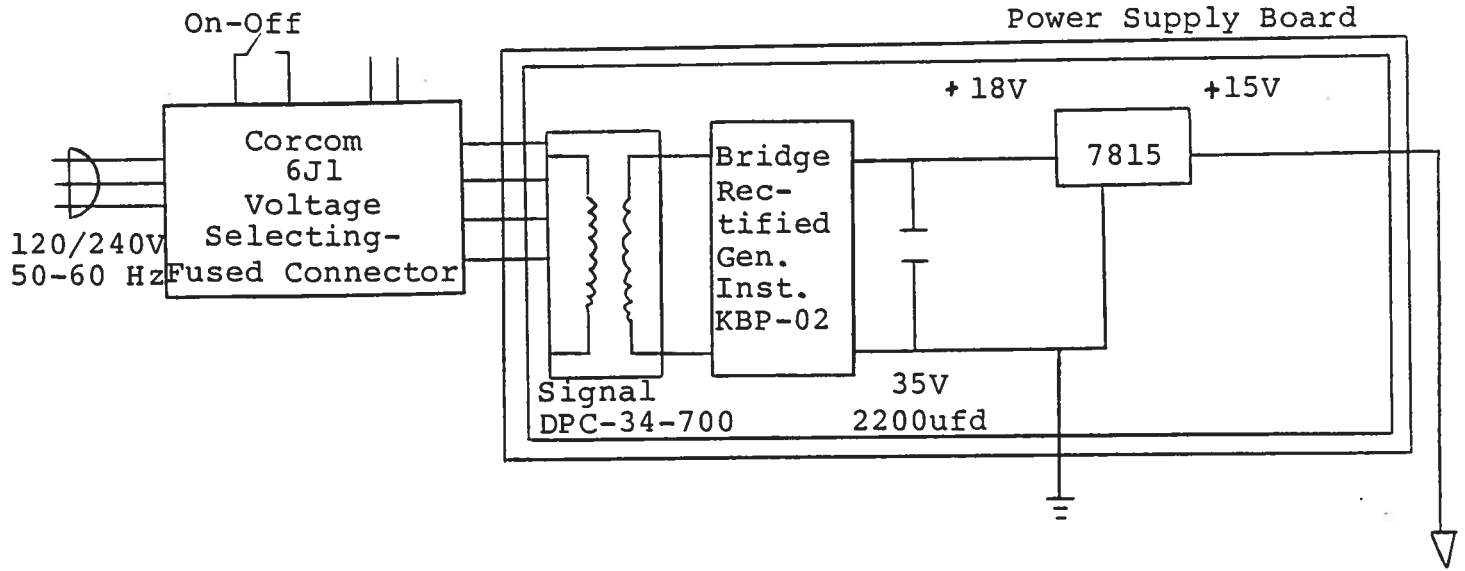

## LINE POWERED AVL-AV-1 SYSTEM DESCRIPTION AND REPAIR PROCEDURE

The AVL-AV-1-PS consists of the two standard modules and a power supply board which supplies +15 Volts (600 mA max) to the pulse generator modules. In the event that the AVL-AV-1-PS unit malfunctions, remove the instrument top cover by removing the four Phillips screws on the back of the unit. Measure the voltage at the +15 V pin of the PG module. If this voltage is substantially less than +15 Volts, unsolder the line connecting the power supply board and PG module and connect a 50 Ohm 10 W load to the power supply output. The voltage across this load should be about 15 V DC. If this voltage is substantially less than 15 Volts the power supply board is defective and should be repaired or replaced. If the voltage is near +15V then see instructions in preceding section.

Jan. 7/97

Edition B

-PN

-M

-OS

Disk: AVL-A

Name: AV1PSEDB.INS