

**AVTECH ELECTROSYSTEMS LTD.**

**NANOSECOND WAVEFORM ELECTRONICS  
ENGINEERING - MANUFACTURING**

□ P.O. BOX 265  
OGDENSBURG  
NEW YORK  
13669  
(315) 472-5270

✕ □ BOX 5120 STN. "F"  
OTTAWA, ONTARIO  
CANADA K2C 3H4  
(613) 226-5772  
TELEX 053-4591

INSTRUCTIONS

MODEL AVL-AV-1-C-W PULSE GENERATOR

S.N. :

## WARRANTY

Avtech Electrosystems Ltd. warrants products of its manufacture to be free from defects in material and workmanship under conditions of normal use. If, within one year after delivery to the original owner, and after prepaid return by the original owner, this Avtech product is found to be defective, Avtech shall at its option repair or replace said defective item. This warranty does not apply to units which have been disassembled, modified or subjected to conditions exceeding the applicable specifications or ratings. This warranty is the extent of the obligation or liability assumed by Avtech with respect to this product and no other warranty or guarantee is either expressed or implied.

Fig. 1

PULSE GENERATOR TEST ARRANGEMENT

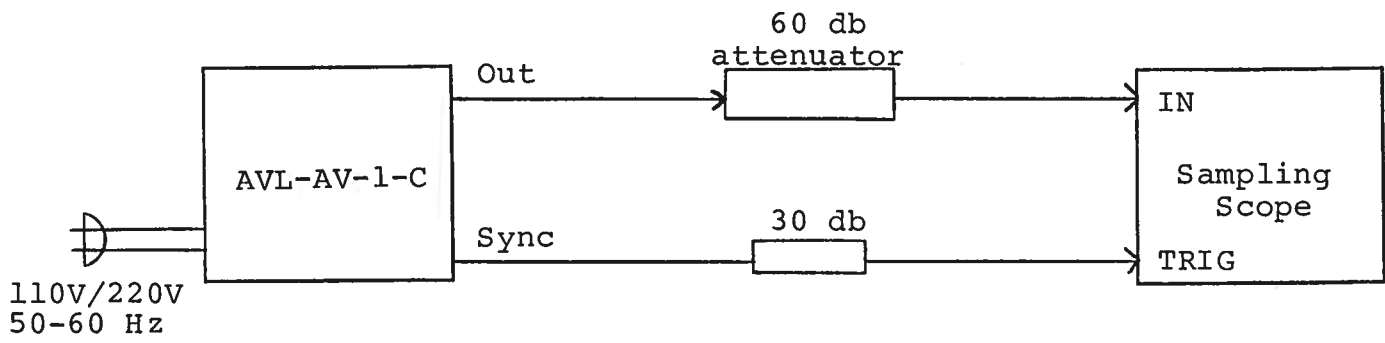

Notes:

- 1) The bandwidth capability of components and instruments used to display the pulse generator output signal (attenuators, cables, connectors, etc.) should exceed one gigahertz.
- 2) The use of 60 db attenuator at the sampling scope vertical input channel will insure a peak input signal to the sampling scope of less than one volt.
- 3) The sync output channel provides TTL level signals. To avoid overdriving the TRIG input channel of some sampling scopes, a 30 db attenuator should be placed at the input to the sampling scope trigger channel.
- 4) To obtain a stable output display the PRF and PRF FINE controls on the front panel should be set mid-range. The front panel TRIG toggle switch should be in the INT position. The front panel DELAY control and the scope triggering controls are then adjusted to obtain a stable output. The scope may then be used to set the desired PRF by rotating the PRF and PRF FINE controls. The main output is delayed with respect to the SYNC output by about 0 to 150 nsec depending on the DELAY control setting.
- 5) The output pulse width is controlled by means of the one turn potentiometers (PW and PW FINE). The pots should initially be set mid-range and the pulse width adjusted using an oscilloscope. The output will degenerate to an impulse and eventually vanish as the pot is turned fully counter clockwise. Units with the -W option are shipped with an 8 inch length of RG-58 cable connected between ports A and B on the back panel. This cable provides a maximum PW of about 100 nsec. The maximum PW may be extended up to 400 nsec by attaching RG-58 cable lengths of about 100 feet between ports A and B. The maximum attainable PW varies linearly with cable length for cable lengths between 6" and 100 feet. CAUTION: Insure that the input power is off before attempting to change the cable between ports A and B. Potentials as high as 400V exist on the centre conductor between ports A and B.
- 6) The output pulse amplitude is controlled by means of the one turn potentiometer (AMP).
- 7) An external clock may be used to control the output PRF of the AVL unit by setting the front panel TRIG toggle switch in the EXT position and applying a 0.2 usec (approx.) TTL level pulse to the TRIG BNC connector input. For operation in this mode, the scope time base must also be triggered by the external clock rather than

from the SYNC output. WARNING: Model AVL-AV-1 may fail if triggered at a PRF greater than 5 KHz.

- 8) Model AVL-AV-1 can withstand an infinite VSWR on the output port but is intended for operation with 50 ohm loads.
- 9) NOTE: The lifetime of the switching elements in the pulse generator module is proportional to the running time of the instrument. For this reason the prime power to the instrument should be turned off when the instrument is not in use. In the case of failure, the switching elements are easily replaced following the procedure described in the following section.
- 10) The desired DC offset is applied to the back panel OS terminals which are connected to the output centre conductor via a high quality RF inductor. Do not exceed  $\pm 50V$ , 0.1 amp. (option).
- 11) The back monitor output provides an attenuated replica (20 db down) of the output less DC offset. The monitor output is designed to operate into a 50 ohm load. (option).

Fig. 2

FRONT PANEL CONTROLS

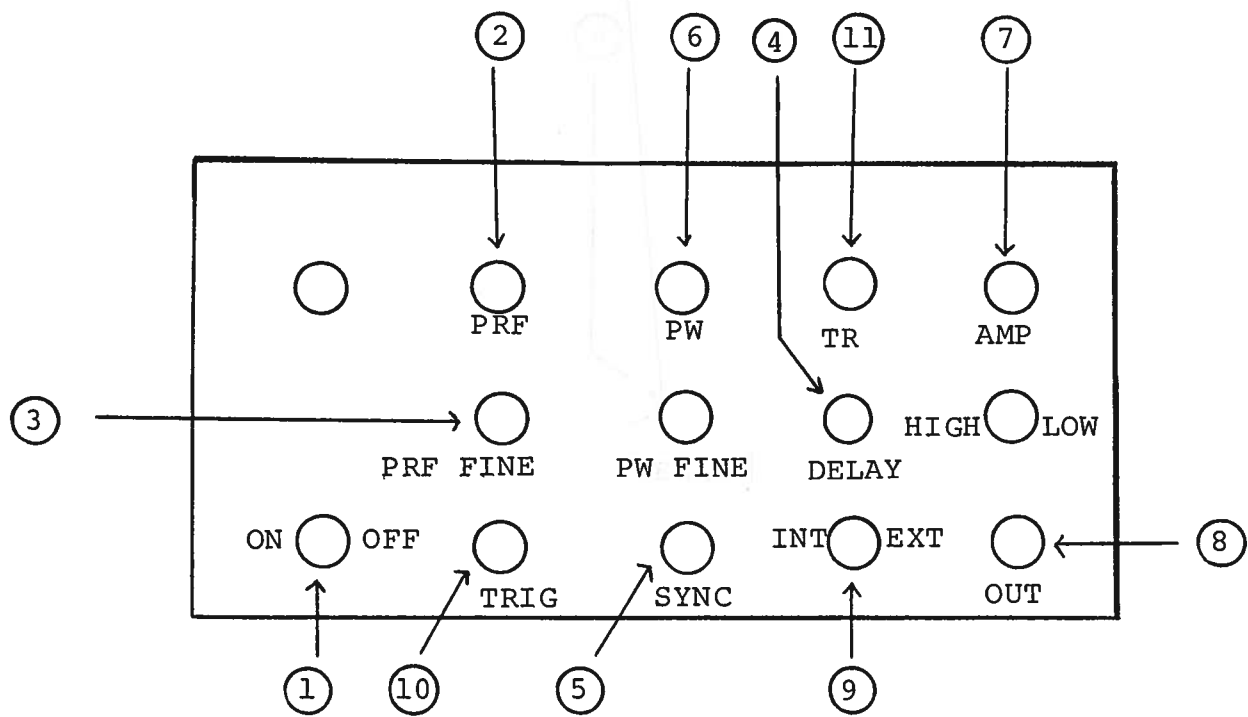

- (1) ON-OFF Switch. Applies basic prime power to all stages.
- (2) PRF Control. Varies PRF from about 50 Hz to about 5 KHz. The operating PRF should be set using a sampling scope.
- (3) PRF FINE Control. This control varies PRF but is about 10 times less sensitive than the main PRF control.
- (4) DELAY Control. Controls the relative delay between the reference output pulse provided at the SYNC output (5) and the main output (8). This delay is variable over the range of about 0 to 150 nsec.
- (5) SYNC Output. This output precedes the main output (8) and is used to trigger the sampling scope time base. The output is a TTL level 100 nsec (approx.) pulse capable of driving a fifty ohm load.
- (6) PW and PW FINE Control. One-turn controls which vary the output pulse width from 0 to 100 nsec (to 400 nsec for -W option).
- (7) AMP Control. The output pulse amplitude is controlled by means of the one-turn potentiometer (AMP).
- (8) OUT Connector. BNC connector provides output to a fifty ohm load.
- (9) EXT-INT Control. With this toggle switch in the INT position, the PRF of the AVL unit is controlled via an internal clock which in turn is controlled by the PRF and PRF FINE controls. With the toggle switch in the EXT position, the AVL unit requires a 0.2 usec TTL level pulse applied at the TRIG input in order to trigger the output stages. In addition, in this mode, the scope time base must be triggered by the external trigger source.
- (10) TRIG Input. The external trigger signal is applied at this input when the EXT toggle switch is in the EXT position. The output pulse at (8) appears about 350 nsec after the application of the TRIG pulse.
- (11) RISE TIME Control (Option). Varies rise and fall times in one nanosecond increments from about one to ten nanoseconds.

Fig. 3

BACK PANEL CONTROLS

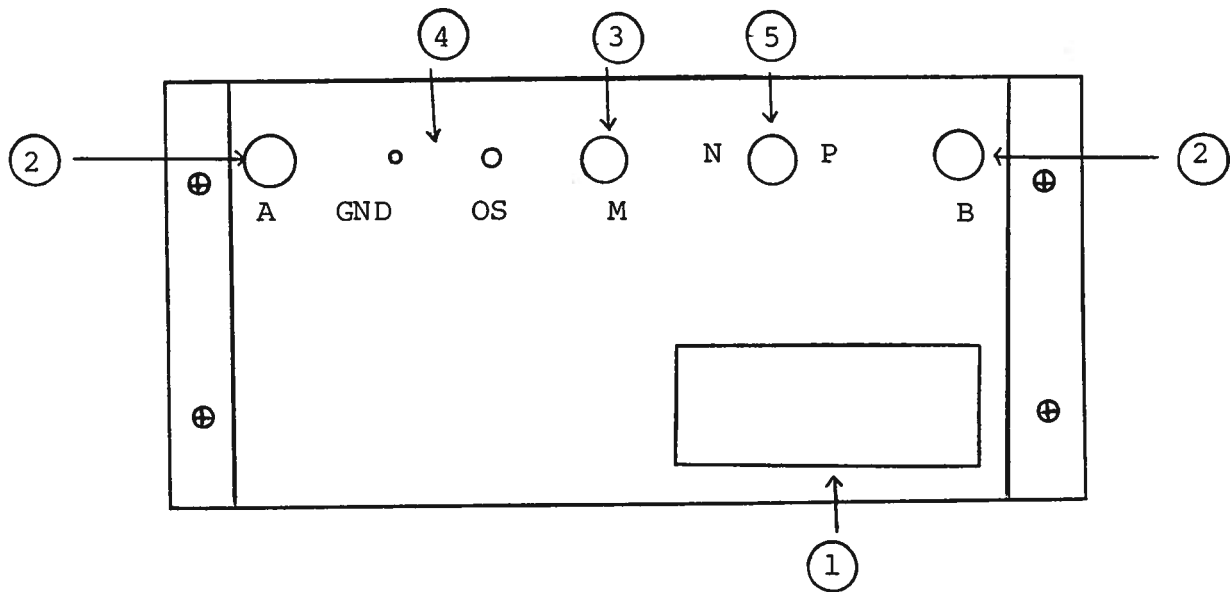



- (1) FUSED CONNECTOR, VOLTAGE SELECTOR. The detachable power cord is connected at this point. In addition, the removable cord is adjusted to select the desired input operating voltage. The unit also contains the main power fuse.
- (2) PW Range Cable. Units with the -W option are shipped with an 8 inch length of RG-58 cable connected between ports A and B on the back panel. This cable provides a maximum PW of about 100 nsec. The maximum PW may be extended up to 400 nsec by attaching RG-58 cable lengths of about 100 feet between ports A and B. The maximum attainable PW varies linearly with cable length for cable lengths between 6" and 100 feet.  
CAUTION: Insure that the input power is off before attempting to change the cable between ports A and B. Potentials as high as 400V exist on the centre conductor between ports A and B.
- (3) MONITOR Output. The back monitor output provides an attenuated replica (20 db down) of the output less DC offset. The monitor output is designed to operate into a 50 ohm load. (Option).
- (4) DC Offset. The desired DC offset is applied to the back panel DS terminals which are connected to the output centre conductor via a high quality RF inductor. Do not exceed  $\pm 50V$ , 0.1 amp. (Option).
- (5) OUTPUT POLARITY CONTROL (Option). With switch in (P) position, output is positive. With switch in (N) position, output pulse is negative.

## REPAIR PROCEDURE

- 1) **WARNING:** Before attempting any repairs, note that potentials as high as 400 volts are employed in the chassis structure.
  
- 2) The pulse generator is constructed from the following basic subsystems or modules:
  - a) Metal chassis
  - b) Pulse generator module (AVL-AV-1-PG)
  - c) Power supply module (AVL-2A-PS)
  - d) Clock module (AVL-2A-CL)
  - e) Power supply boardThe three modules are interconnected as shown in Fig. 1.
  
- 3) If no output pulse is provided by the AVL-AV-1 unit, turn off the prime power supply and remove the top cover panel by removing the four Phillips screws on the back side of the instrument. The top cover will then slide out to expose the interior. Apply a scope probe or voltmeter to pin 6 of the AVL-AV-1-PG unit. Turn on the prime power supply. A voltage of about 360 to 380 volts should be read at pin 6. If the voltage is zero or much less than 380 volts, then one of the switching transistors (Part No. SL3) in the AVL-AV-1-PG module has probably failed. **WARNING:** The cases of the transistors are at potentials as high as 380 volts. With the prime power supply off remove one of the transistors by removing the two 2-56 screws which secure the transistor in its socket. Pull the transistor out of the socket. With the unit un-triggered turn on the prime power supply and measure the voltage from the case of the remaining transistor to ground. If the voltage is about 360 to 380 volts then the transistor which was removed is defective and should be replaced. If the voltage which is measured is less than 360 volts then the transistor still in position is defective and should be replaced. Note that the two transistors are completely interchangeable (Order Avtech Part No. SL3). Note that with both transistors removed, the voltage at pin 6 on the AVL-AV-1-PG module should be in the range of 360 to 380 volts. If the voltage is less then the AVL-2A-PS module must be replaced.

The AVL-2A-CL module is functioning properly if:

- a) The TTL level output at pin 2 varies from 50 Hz to 5 KHz as the PRF control is varied.
  
- b) The relative delay between the output at pins 2 and 3 varies by about 100 to 200 nsec as the DELAY control is varied.

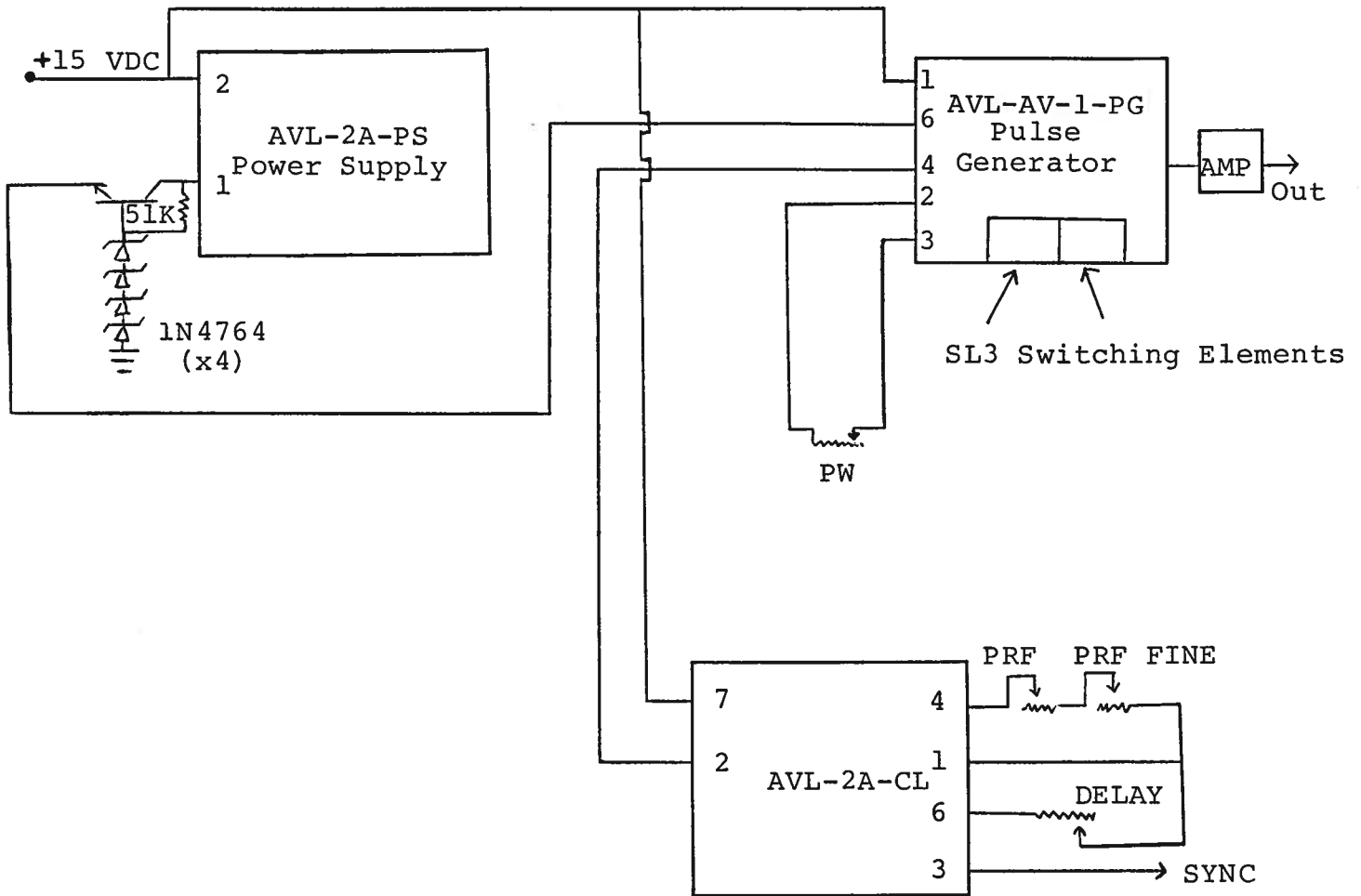

Fig. 1

Notes:

- 1) All module chassis are grounded to main chassis and to each other via separate ground lines.
- 2) **WARNING:** The line connecting pin 1 of AVL-2A-PS to pin 6 of AVL-AV-1-PG is a potential of 375 to 400 volts.

## LINE POWERED AVL-AV-1 SYSTEM DESCRIPTION AND REPAIR PROCEDURE

The AVL-AV-1-C consists of the three standard modules and a power supply board which supplies +15 volts (600 mA max) to the pulse generator modules. In the event that the AVL-2A unit malfunctions, remove the instrument cover by removing the two screws on each side of the unit, thereby exposing the modules. Measure the voltage at the +15 V pin of the PG module. If this voltage is substantially less than +15 volts, unsolder the line connecting the power supply board and PG module and connect a 50 ohm 10 W load to the power supply output. The voltage across this load should be about 15 V DC. If this voltage is substantially less than 15 volts the power supply board is defective and should be repaired or replaced. If the voltage is near +15V then see instructions in preceding section.

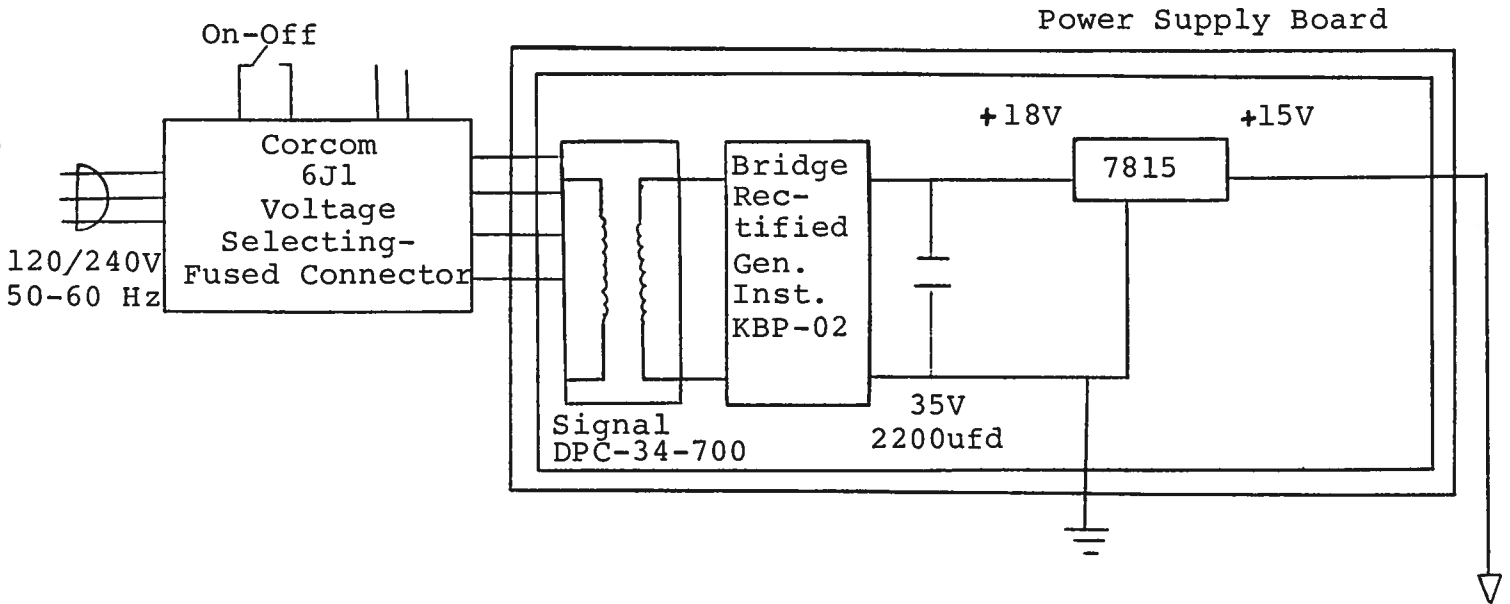

Schroff 09.04.87 Edition A

-OS

-M

-PN

-T