

AVTECH ELECTROSYSTEMS LTD.

**NANOSECOND WAVEFORM ELECTRONICS
ENGINEERING . MANUFACTURING**

□ P.O. BOX 265
OGDENSBURG
NEW YORK
13669
(315) 472-5270

Y
□ BOX 5120 STN. "F"
OTTAWA, ONTARIO
CANADA K2C 3H4
(613) 226-5772
TELEX 053-4591

INSTRUCTIONS

MODEL AVL-MA-1 IMPULSE GENERATOR

S.N. :

WARRANTY

Avtech Electrosystems Ltd. warrants products of its manufacture to be free from defects in material and workmanship under conditions of normal use. If, within one year after delivery to the original owner, and after prepaid return by the original owner, this Avtech product is found to be defective, Avtech shall at its option repair or replace said defective item. This warranty does not apply to units which have been disassembled, modified or subjected to conditions exceeding the applicable specifications or ratings. This warranty is the extent of the obligation or liability assumed by Avtech with respect to this product and no other warranty or guarantee is either expressed or implied.

MODEL AVL-MA-1 PULSE GENERATOR TEST ARRANGEMENT

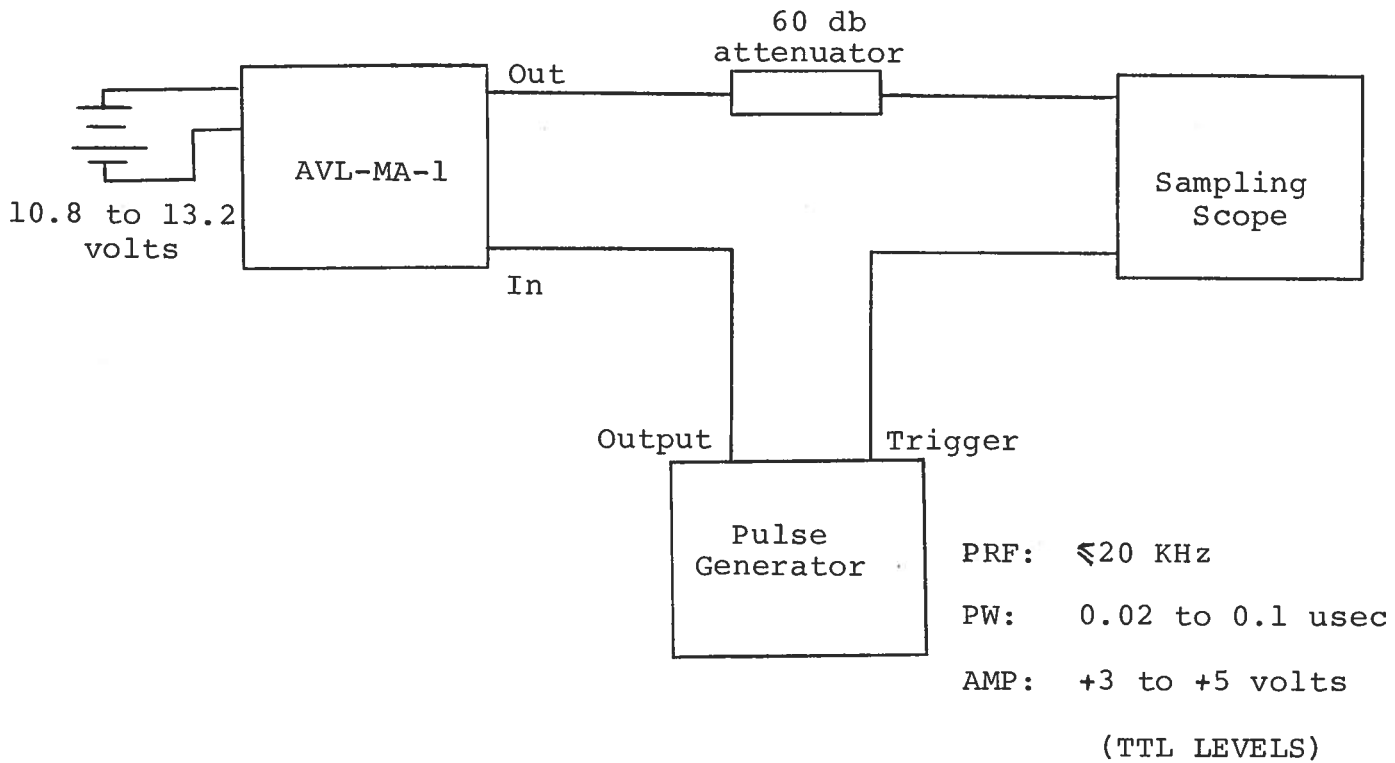

Notes:

- 1) The bandwidth capability of components and instruments used to display the impulse generator output signal (attenuators, cables, connectors, etc.) should exceed several gigahertz.
- 2) The use of 60 db attenuators will insure a peak input signal to the sampling scope of less than one volt.
- 3) In general, the pulse generator trigger delay control should be set in the 100 nsec range. Other settings should be as shown in the above diagram. The AVL pulse generator output is delayed with respect to the trigger input signal by about 30 nsec. (typically)
- 4) The pulse generator can withstand an infinite VSWR on the output port.

TARGET SPECIFICATIONS

Output amplitude (to 50 ohms):	100 volts (constant, not variable)
Pulse width:	6 nsec (3 db point) (constant, not variable)
Rise time, fall time:	≤700 psec (10% to 90%)
PRF:	200 - 10,000 Hz. Requires external TTL trigger (0.1 usec) Output PRF equals input PRF
Temperature range:	-30 C to +70 C
Power supply:	+10.8 to +13.2 volts Supply current to be as low as possible (less than 75 mA for PRF of 256 Hz)
Package size:	Avtech package A (See Cat. No. 4, page 8)
Output connectors:	SMA
Input trigger connector:	2 pin solder terminal
Input power connector:	2 pin solder terminal
Other:	Propagation delay time variation less than 0.75 nsec over full temperature range (and with time)