



AVTECH ELECTROSYSTEMS LTD.

NANOSECOND WAVEFORM ELECTRONICS
SINCE 1975

P.O. BOX 265
OGDENSBURG, NY
U.S.A. 13669-0265
TEL: (315) 472-5270
FAX: (613) 226-2802

TEL: 1-800-265-6681
FAX: 1-800-561-1970
e-mail: info@avtechpulse.com
<http://www.avtechpulse.com/>

BOX 5120, LCD MERIVALE
OTTAWA, ONTARIO
CANADA K2C 3H4
TEL: (613) 226-5772
FAX: (613) 226-2802

INSTRUCTIONS

MODEL AVN-4-C

50 MHz TO 250 MHz

HIGH SPEED PULSE GENERATOR

WITH 150 ps RISE & FALL TIMES

SERIAL NUMBER: _____

WARRANTY

Avtech Electrosystems Ltd. warrants products of its manufacture to be free from defects in material and workmanship under conditions of normal use. If, within one year after delivery to the original owner, and after prepaid return by the original owner, this Avtech product is found to be defective, Avtech shall at its option repair or replace said defective item. This warranty does not apply to units which have been disassembled, modified or subjected to conditions exceeding the applicable specifications or ratings. This warranty is the extent of the obligation assumed by Avtech with respect to this product and no other warranty or guarantee is either expressed or implied.

TECHNICAL SUPPORT

Phone: 613-226-5772 or 1-800-265-6681

Fax: 613-226-2802 or 1-800-561-1970

E-mail: info@avtechpulse.com

World Wide Web: <http://www.avtechpulse.com>

TABLE OF CONTENTS

WARRANTY.....	2
TECHNICAL SUPPORT.....	2
TABLE OF CONTENTS.....	3
INTRODUCTION.....	5
AVAILABLE OPTIONS.....	5
SPECIFICATIONS.....	6
EUROPEAN REGULATORY NOTES.....	7
EC DECLARATION OF CONFORMITY.....	7
DIRECTIVE 2002/95/EC (RoHS).....	7
INSTALLATION.....	8
VISUAL CHECK.....	8
POWER RATINGS.....	8
CONNECTION TO THE POWER SUPPLY.....	8
PROTECTION FROM ELECTRIC SHOCK.....	9
ENVIRONMENTAL CONDITIONS.....	9
FUSES.....	11
AC FUSE REPLACEMENT.....	11
DC FUSE REPLACEMENT.....	12
FUSE RATINGS.....	12
FRONT PANEL CONTROLS.....	13
REAR PANEL CONTROLS.....	15
GENERAL INFORMATION.....	16
BASIC TEST ARRANGEMENT.....	16
GENERAL OPERATING NOTES.....	16
MINIMIZING WAVEFORM DISTORTIONS.....	19
USE 50 OHM TRANSMISSION LINES AND LOADS.....	19
USE LOW-INDUCTANCE LOADS.....	19
PREVENTING DAMAGE.....	19
OPTIONS.....	20
-OT OPTION.....	20
-M OPTION.....	20
-ECL OPTION.....	20

MECHANICAL INFORMATION.....	21
TOP COVER REMOVAL.....	21
RACK MOUNTING.....	21
ELECTROMAGNETIC INTERFERENCE.....	21
MAINTENANCE.....	22
REGULAR MAINTENANCE.....	22
CLEANING.....	22
WIRING DIAGRAMS.....	23
WIRING OF AC POWER.....	23
PCB 158G - LOW VOLTAGE POWER SUPPLY, 1/3.....	24
PCB 158G - LOW VOLTAGE POWER SUPPLY, 2/3.....	25
PCB 158G - LOW VOLTAGE POWER SUPPLY, 3/3.....	26
MAIN WIRING.....	27
PERFORMANCE CHECK SHEET.....	28

Manual Reference: T:\instructword\avn\AVN-4-C,editiong.sxw.
Last modified March 30, 2005.
Copyright © 2005 Avtech Electrosystems Ltd, All Rights Reserved.

INTRODUCTION

The AVN-4-C pulse generator is a high performance instrument capable of operating at pulse repetition frequencies from 50 MHz to 250 MHz, with 150 ps rise and fall times. The pulse width is variable from 0.3 to 1.0 ns. The maximum amplitude is 20V for repetition rates up to 100 MHz, falling to 15V at 150 MHz, and 5V at 250 MHz.

Instruments with the "-P" model suffix can generate positive amplitudes, whereas instruments with the "-N" model suffix can generate negative amplitudes.

Instruments with the "-P-PN" suffix generate positive amplitudes at the main output, and are supplied with an inverting transformer that can be installed on the output to generate a negative signal.

Instruments with the "-N-PN" suffix generate negative amplitudes at the main output, and are supplied with an inverting transformer that can be installed on the output to generate a positive signal.

The output is designed to drive 50 Ω loads. (A 50 Ω load is required for proper operation.) The output is AC-coupled.

This instrument is intended for use in research and development laboratories.

AVAILABLE OPTIONS

The AVN-4-C is available with several options:

-OT Option: an internally generated DC offset can be added to the output.

-M Option: a monitor output is provided.

-ECL Option: the required input trigger signal is an ECL 50% duty cycle square wave, rather than the standard 0.3V RMS sine wave.

SPECIFICATIONS

Model:	AVN-4-C ¹
Amplitude: (50 Ohm load)	0 to 20V at \leq 100 MHz, falling to 0 to 15V at 150 MHz, and 0 to 5 V at 250 MHz
Pulse width:	Variable 0.3 to 1.0 ns
PRF:	50 MHz to 250 MHz
Rise time:	\leq 150 ps
Fall time:	\leq 150 ps
Polarity ² :	Positive or negative or both (specify)
Propagation delay:	\leq 5 ns (Ext trig in to pulse out)
Jitter:	\pm 15 ps (Ext trig in to pulse out)
DC offset or bias insertion ³ :	Apply required DC offset to back panel solder terminals (\pm 50 Volts, 250 mA max)
Trigger required:	ext trig mode: 0.3 V RMS sine wave or 50% duty cycle square wave
Sync output:	50 mV square wave
Monitor output option ⁴ :	Provides a 20 dB attenuated coincident replica of main output
Connectors:	Out: SMA, Trig: BNC, Sync: BNC, Monitor: SMA
Power requirement:	100 - 240 Volts, 50-60 Hz
Dimensions (H x W x D):	100 mm x 430 mm x 375 mm (3.9" x 17" x 14.8")
Chassis material:	anodized aluminum, with blue plastic trim

- 1) -C suffix indicates stand-alone lab instrument with internal clock and line powering.
- 2) Indicate desired polarity by suffixing the model number with -P or -N (i.e. positive or negative) or -P-PN or -N-PN for dual polarity option where the suffix preceding -PN indicates the polarity at the mainframe output port. (-PN not available on modules).
- 3) For internally generated DC offset option (0 to +/- 5 V, one-turn control) add suffix -OT to the model number. Not available on modules.
- 4) For monitor option add suffix -M. Not available on modules.

EUROPEAN REGULATORY NOTES

EC DECLARATION OF CONFORMITY

We

Avtech Electrosystems Ltd.
P.O. Box 5120, LCD Merivale
Ottawa, Ontario
Canada K2C 3H4

declare that this pulse generator meets the intent of Directive 89/336/EEC for Electromagnetic Compatibility. Compliance pertains to the following specifications as listed in the official Journal of the European Communities:

EN 50081-1 Emission

EN 50082-1 Immunity

and that this pulse generator meets the intent of the Low Voltage Directive 72/23/EEC as amended by 93/68/EEC. Compliance pertains to the following specifications as listed in the official Journal of the European Communities:

EN 61010-1:2001 Safety requirements for electrical equipment for measurement, control, and laboratory use



DIRECTIVE 2002/95/EC (RoHS)

This instrument is exempt from Directive 2002/95/EC of the European Parliament and of the Council of 27 January 2003 on the Restriction of the use of certain Hazardous Substances (RoHS) in electrical and electronic equipment. Specifically, Avtech instruments are considered "Monitoring and control instruments" (Category 9) as defined in Annex 1A of Directive 2002/96/EC. The Directive 2002/95/EC only applies to Directive 2002/96/EC categories 1-7 and 10, as stated in the "Article 2 - Scope" section of Directive 2002/95/EC.

INSTALLATION

VISUAL CHECK

After unpacking the instrument, examine to ensure that it has not been damaged in shipment. Visually inspect all connectors, knobs, and handles. Confirm that a power cord is with the instrument. If the instrument has been damaged, file a claim immediately with the company that transported the instrument.

POWER RATINGS

This instrument is intended to operate from 100 - 240 V, 50 - 60 Hz.

The maximum power consumption is 57 Watts. Please see the "FUSES" section for information about the appropriate AC and DC fuses.

This instrument is an "Installation Category II" instrument, intended for operation from a normal single-phase supply.

CONNECTION TO THE POWER SUPPLY

An IEC-320 three-pronged recessed male socket is provided on the back panel for AC power connection to the instrument. One end of the detachable power cord that is supplied with the instrument plugs into this socket. The other end of the detachable power cord plugs into the local mains supply. Use only the cable supplied with the instrument. The mains supply must be earthed, and the cord used to connect the instrument to the mains supply must provide an earth connection. (The supplied cord does this.)

 **Warning:** Failure to use a grounded outlet may result in injury or death due to electric shock. This product uses a power cord with a ground connection. It must be connected to a properly grounded outlet. The instrument chassis is connected to the ground wire in the power cord.

The table below describes the power cord that is normally supplied with this instrument, depending on the destination region:

Destination Region	Description	Manufacturer	Part Number
Continental Europe	European CEE 7/7 "Schuko" 230V, 50Hz	Volex (http://www.volex.com)	17850-C3-326
United Kingdom	BS 1363, 230V, 50Hz	Volex (http://www.volex.com)	17962-C3-10
Switzerland	SEV 1011, 230V, 50Hz	Volex (http://www.volex.com)	2102H-C3-10
Israel	SI 32, 220V, 50Hz	Volex (http://www.volex.com)	2115H-C3-10
North America, and all other areas	NEMA 5-15, 120V, 60 Hz	Volex (http://www.volex.com)	17250-B1-10
		Qualtek (http://www.qualtekusa.com)	312007-01

PROTECTION FROM ELECTRIC SHOCK

 Operators of this instrument must be protected from electric shock at all times. The owner must ensure that operators are prevented access and/or are insulated from every connection point. In some cases, connections must be exposed to potential human contact. Operators must be trained to protect themselves from the risk of electric shock. This instrument is intended for use by qualified personnel who recognize shock hazards and are familiar with safety precautions required to avoid possibly injury. In particular, operators should:

- 1) Keep exposed high-voltage wiring to an absolute minimum.
- 2) Wherever possible, use shielded connectors and cabling.
- 3) Connect and disconnect loads and cables only when the instrument is turned off.
- 4) Keep in mind that all cables, connectors, oscilloscope probes, and loads must have an appropriate voltage rating.
- 5) Do not attempt any repairs on the instrument, beyond the fuse replacement procedures described in this manual. Contact Avtech technical support (see page 2 for contact information) if the instrument requires servicing. Service is to be performed solely by qualified service personnel.

ENVIRONMENTAL CONDITIONS

This instrument is intended for use under the following conditions:

- 1) indoor use;
- 2) altitude up to 2 000 m;
- 3) temperature 5 °C to 40 °C;
- 4) maximum relative humidity 80 % for temperatures up to 31 °C decreasing linearly to 50 % relative humidity at 40 °C;
- 5) Mains supply voltage fluctuations up to ± 10 % of the nominal voltage;

6) no pollution or only dry, non-conductive pollution.

FUSES

This instrument contains four fuses. All are accessible from the rear-panel. Two protect the AC prime power input, and two protect the internal DC power supplies. The locations of the fuses on the rear panel are shown in the figure below:

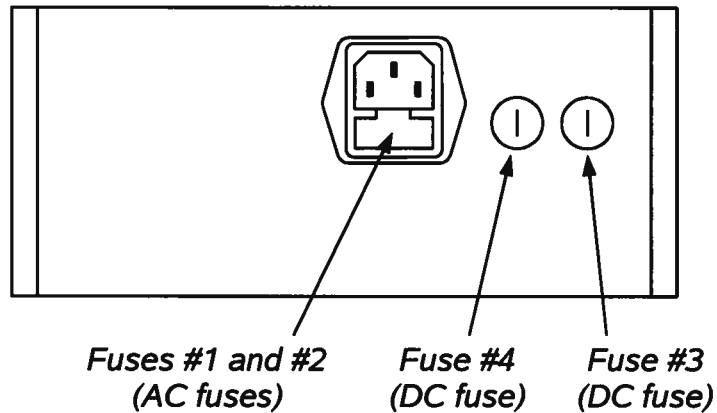

AC FUSE REPLACEMENT

To physically access the AC fuses, the power cord must be detached from the rear panel of the instrument. The fuse drawer may then be extracted using a small flat-head screwdriver, as shown below:

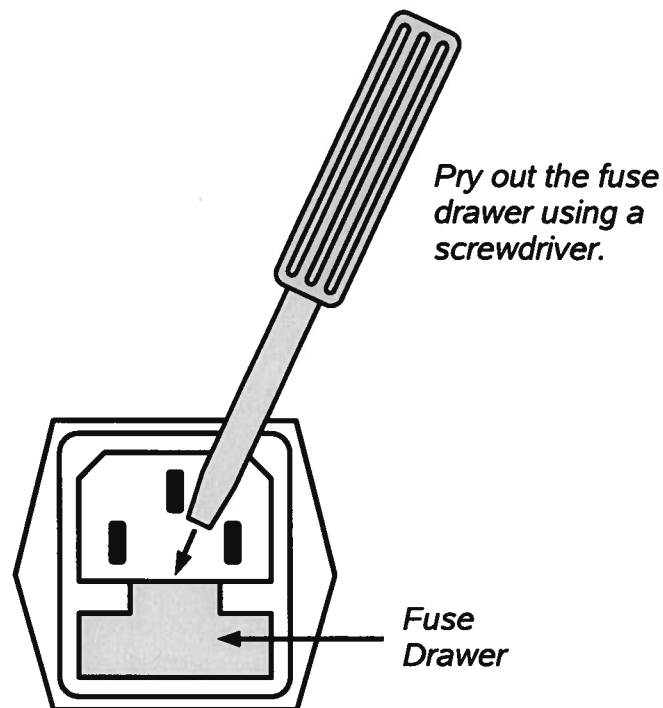

DC FUSE REPLACEMENT

The DC fuses may be replaced by inserting the tip of a flat-head screwdriver into the fuse holder slot, and rotating the slot counter-clockwise. The fuse and its carrier will then pop out.

FUSE RATINGS

The following table lists the required fuses:

Fuses	Nominal Mains Voltage	Rating	Case Size	Manufacturer's Part Number (Wickmann)	Distributor's Part Number (Digi-Key)
#1, #2 (AC)	100-240V	0.5A, 250V, Time-Delay	5×20 mm	1950500000	WK5041-ND
#3 (DC)	N/A	1.6A, 250V, Time-Delay	5×20 mm	1951160000	WK5053-ND
#4 (DC)	N/A	1.0A, 250V, Time-Delay	5×20 mm	1951100000	WK5048-ND

The fuse manufacturer is Wickmann (<http://www.wickmann.com/>).

Replacement fuses may be easily obtained from Digi-Key (<http://www.digikey.com/>) and other distributors.

FRONT PANEL CONTROLS

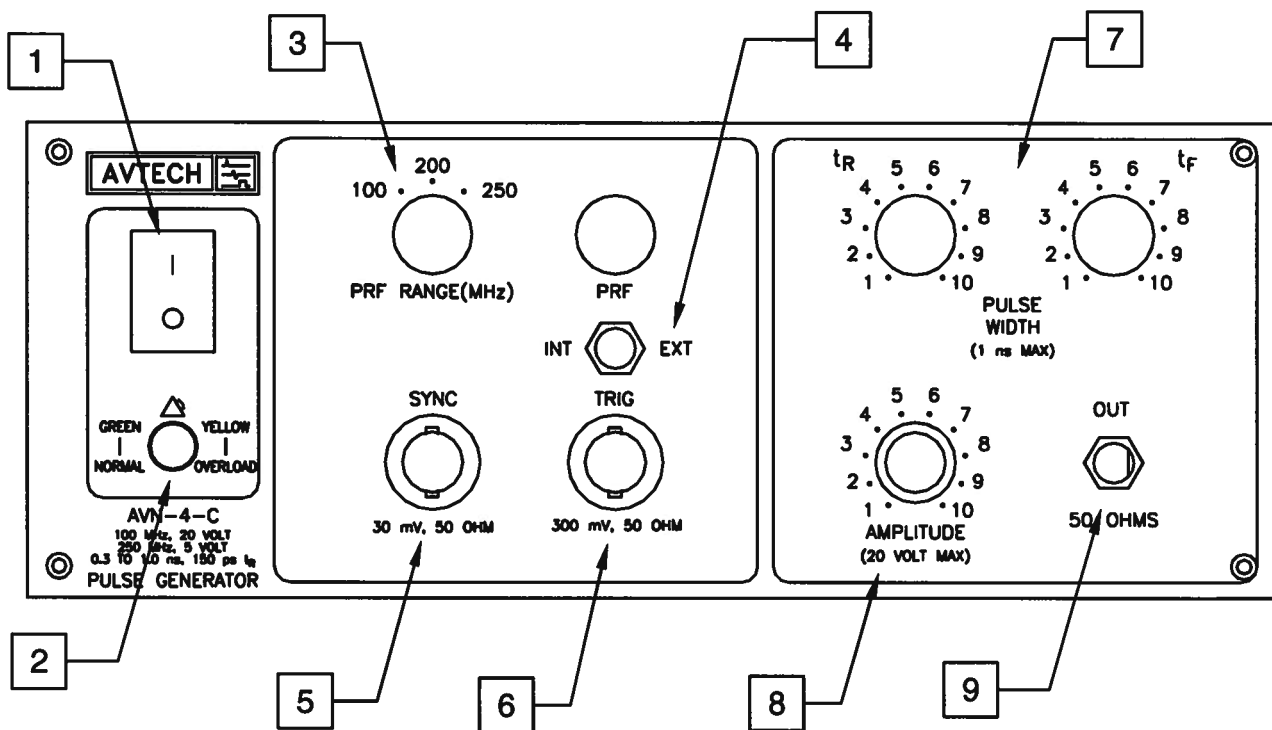

1. **POWER Switch**. This is the main power switch. When turning the instrument on, there may be a delay of several seconds before the instrument appears to respond.
2. **OVERLOAD Indicator**. When the instrument is powered, this indicator is normally green, indicating normal operation. If this indicator is yellow, an internal automatic overload protection circuit has been tripped. If the unit is overloaded (by operating at an exceedingly high duty cycle or by operating into a very low impedance), the protective circuit will disable the output of the instrument and turn the indicator light yellow. The light will stay yellow (i.e. output disabled) for about 5 seconds after which the instrument will attempt to re-enable the output (i.e. light green) for about 1 second. If the overload condition persists, the output will be disabled again (i.e. light yellow) for another 5 seconds. If the overload condition has been removed, the instrument will resume normal operation.

This overload indicator may flash yellow briefly at start-up. This is not a cause for concern.

Note that the output stage will safely withstand a short-circuited load condition.

3. **PRF Range Switch**. This switch sets the pulse repetition frequency (PRF) range of the internal oscillator. The marked value of each position is the upper limit of the range, approximately. The vernier dial directly to the right of the switch varies the

PRF within the set range.

If this switch is set to the "EXT" position, the instrument is triggered by a signal applied to the TRIG connector, rather than by the internal oscillator.

4. INT / EXT Switch. When this switch is in the INT position, the instrument is triggered by the internal oscillator, whose repetition frequency is controlled by item (2).

When this switch is in the EXT position, standard models require a 0.3 V RMS sine wave applied at the TRIG input in order to trigger the output stages, and the input is terminated internally with 50 Ohms to ground. For models with the -ECL option, an ECL-level square wave is required instead. In this case, the input is terminated internally with 50 Ohms to -2 Volts. ECL logic levels are -0.8V and -1.6V.

In the EXT mode the oscilloscope time base must be triggered by the external trigger source.

5. SYNC Output. This output is approximately coincident with the main output and may be used to trigger a sampling scope time base. The output is a 50 mV sine wave capable of driving a 50 Ohm load.
6. TRIG Input. The external trigger signal is applied at this input when the EXT-INT toggle switch is in the EXT position. See item (4).
7. TR-TF Controls. These two one-turn controls vary the output pulse width and pulse shape. TR controls the leading edge of the pulse while TF controls the falling edge. Clockwise rotation of TR and TF increases the output pulse width. See the "General Operating Notes" section for more details.
8. AMP Control. This dial varies the output pulse amplitude from zero to maximum output.
9. OUT Connector. This SMA connector provides the main output to a 50 Ohm load.

REAR PANEL CONTROLS

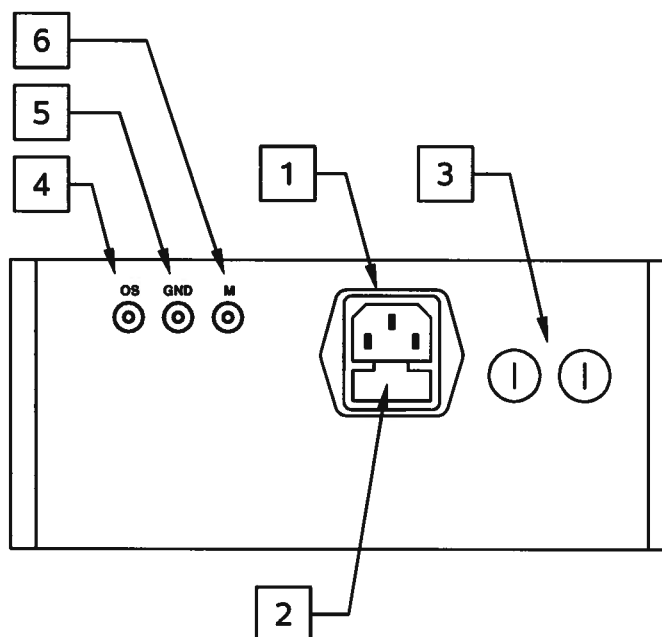

1. **AC POWER INPUT.** An IEC-320 C14 three-pronged recessed male socket is provided on the back panel for AC power connection to the instrument. One end of the detachable power cord that is supplied with the instrument plugs into this socket.
2. **AC FUSE DRAWER.** The two fuses that protect the AC input are located in this drawer. Please see the “FUSES” section of this manual for more information.
3. **DC FUSES.** These two fuses protect the internal DC power supplies. Please see the “FUSES” sections of this manual for more information.
4. **OS INPUT CONNECTOR.** A DC offset in the range of $\pm 50\text{V}$ (250 mA max) may be applied to this solder terminal. The DC offset will appear on the output. When this feature is not used, the OS input should be connected to ground (using the adjacent GND connector). This is especially important when driving loads containing a diode.
5. **GND CONNECTOR.** This solder terminal is connected to ground. It may be used to ground the OS input connector.
6. **M OUTPUT CONNECTOR.** (Present on units with -M option only.) This SMA connector output provides a 20 dB attenuated coincident replica of main output, for monitoring purposes.

GENERAL INFORMATION

BASIC TEST ARRANGEMENT

The AVN-4-C should be tested with a sampling oscilloscope with a bandwidth of at least 10 GHz to properly observe the high-speed waveform. A typical test arrangement is shown below:

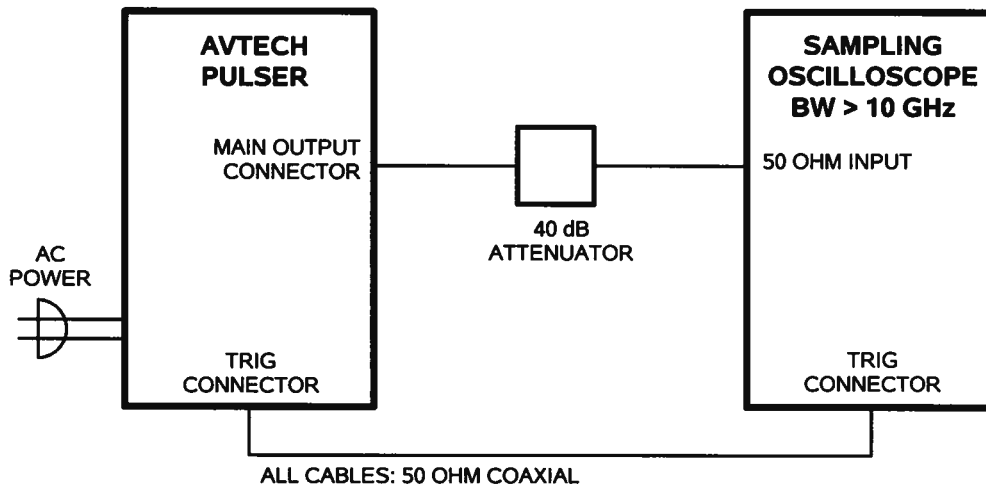

The attenuators are required to prevent damage to the sampling oscilloscope. A 40 dB attenuator with sufficient voltage rating should be used on the main output.

GENERAL OPERATING NOTES

- 1) The bandwidth capability of components and instruments used to display the pulse generator output signal (attenuators, cables, connectors, etc.) should exceed 10 GHz.
- 2) The use of 40 dB attenuator at the sampling scope vertical input channel will insure a peak input signal to the sampling scope of less than 1 Volt.
- 3) The SYNC output provides a 50 mV sine wave (to 50 Ohms).
- 4) To obtain a stable output display the PRF and PRF FINE controls on the front panel should be set mid-range. The front panel TRIG toggle switch should be in the INT position. The scope triggering controls are then adjusted to obtain a stable output.
- 5) The output pulse shape is determined by the two front panel controls TR and TF. TR controls the leading edge of the pulse while TF controls the falling edge. Clockwise rotation of TR and TF increases the output pulse width. Initially rotate the TF pot fully clockwise and set the TR pot at mid-range. The output amplitude

is controlled by the front panel AMP control and by the input signal level. Initially the AMP control should be set maximum clockwise. The CRT display will resemble the following:

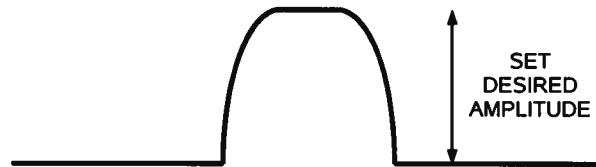

- 6) Having obtained a display of the form shown above, the desired pulse width is then obtained by adjusting the two front panel pots TR and TF. Rotate TR counter clockwise from the position set earlier until a sharp 150 ps leading edge is observed. Then rotate TF counterclockwise until the desired pulse width and fall time are obtained.

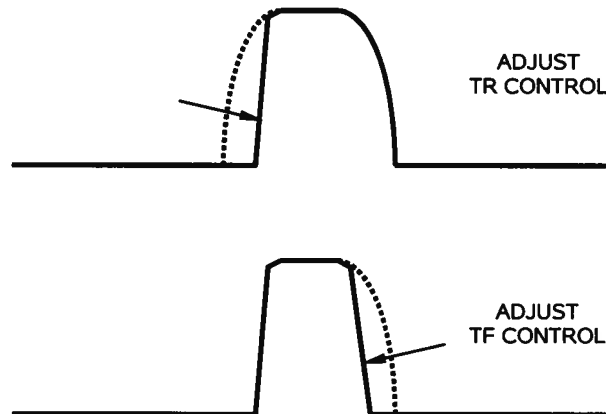

- 7) Further iterative adjustments of TR and TF will be necessary to simultaneously obtain the lowest rise time, lowest fall time, the desired pulse width, and pulse top shape, and low spurious signal level. In addition some additional adjustment of signal level may be necessary to obtain the desired amplitude. If the input frequency is then changed it will be necessary to readjust AMP, TR and TF to establish the required pulse shape. Following the above sequence it is possible to generate output pulses having amplitudes of at least 20, 15 and 5 Volts with pulse repetition frequencies in the range of 50 to 100 MHz, 150 and 250 MHz, respectively.

WARNING: Do not operate below 50 MHz as failure may result. Also, do not exceed 20 Volts out (for frequencies of less than 100 MHz) as this too may result in failure. Failures due to operating at output signals higher than 20 Volts are not covered by the warranty.

- 8) To trigger externally, set the INT-EXT switch to EXT and connect a sine wave generator to the TRIG connector. The output PRF will equal the sine wave PRF. The sine wave amplitude should be set at 0.3 VRMS. (For units with the -ECL

option, the required input signal is an ECL 50% duty cycle square wave, rather than a 0.3 VRMS sine wave.)

- 9) To DC offset the output pulse connect a DC power supply set to required DC offset value to the back panel terminals marked OS. The maximum attainable DC offset voltage is ± 50 Volts (for units without the OT option only).

MINIMIZING WAVEFORM DISTORTIONS

USE 50 OHM TRANSMISSION LINES AND LOADS

Connect the load to the pulse generator with 50Ω transmission lines (e.g. RG-58 or RG-174 cable).

This instrument requires a 50Ω load for proper operation. It will not properly drive a high-impedance load. The output stage will be damaged if it is operated into an open circuit (or any other high impedance). Failures due to improper output loading are not covered by the warranty.

USE LOW-INDUCTANCE LOADS

Lenz's Law predicts that for an inductive voltage spike will be generated when the current through an inductance changes. Specifically, $V_{\text{SPIKE}} = L \times dI_{\text{LOAD}}/dt$, where L is the inductance, I_{LOAD} is the load current change, and t is time. For this reason, it is important to keep any parasitic in the load low. This means keeping wiring short, and using low inductance components. In particular, wire-wound resistors should be avoided.

PREVENTING DAMAGE

The AVN-4-C may fail if triggered at a PRF greater than 250 MHz.

This unit is designed to operate into a load impedance of 50 Ohms and the output stage will be damaged if it is operated into an open circuit (or any other high impedance). Failures due to improper output loading are not covered by the warranty.

The lifetime of the switching elements in the pulse generator module is proportional to the running time of the instrument. For this reason the prime power to the instrument should be turned off when the instrument is not in use.

OPTIONS

The AVN-4-C is available with these options:

-OT OPTION

This option allows an internally generated DC offset to be added to the output. The output DC offset is variable from +5 to -5 Volts by means of the front-panel one-turn OFFSET control. The offset control may be turned off by means of the rear panel ON-OFF OFFSET switch.

-M OPTION

This option provides a monitor output, which is an attenuated replica of the main output. The monitor is connected to the main output through a 470 Ohm resistor, which results in an attenuation of approximately 20 dB (i.e., +10) when the monitor output is terminated with a 50 Ohm load.

The monitor output should be terminated with a 50 Ohm load.

-ECL OPTION

When the instrument is externally triggered, standard models require a 0.3 V RMS sine wave applied at the TRIG input in order to trigger the output stages, and the input is terminated internally with 50 Ohms to ground.

For models with the -ECL option, an ECL-level 50% duty cycle square wave is required instead. In this case, the input is terminated internally with 50 Ohms to -2 Volts. ECL logic levels are -0.8V and -1.6V.

MECHANICAL INFORMATION

TOP COVER REMOVAL

If necessary, the interior of the instrument may be accessed by removing the four Phillips screws on the top panel. With the four screws removed, the top cover may be slid back (and off).

 Always disconnect the power cord and allow the instrument to sit unpowered for 10 minutes before opening the instrument. This will allow any internal stored charge to discharge.

There are no user-adjustable internal circuits. For repairs other than fuse replacement, please contact Avtech (info@avtechpulse.com) to arrange for the instrument to be returned to the factory for repair. Service is to be performed solely by qualified service personnel.

 Caution: High voltages are present inside the instrument during normal operation. Do not operate the instrument with the cover removed.

RACK MOUNTING

A rack mounting kit is available. The -R5 rack mount kit may be installed after first removing the one Phillips screw on the side panel adjacent to the front handle.

ELECTROMAGNETIC INTERFERENCE

To prevent electromagnetic interference with other equipment, all used outputs should be connected to shielded loads using shielded coaxial cables. Unused outputs should be terminated with shielded coaxial terminators or with shielded coaxial dust caps, to prevent unintentional electromagnetic radiation. All cords and cables should be less than 3m in length.

MAINTENANCE

REGULAR MAINTENANCE

This instrument does not require any regular maintenance.

On occasion, one or more of the four rear-panel fuses may require replacement. All fuses can be accessed from the rear panel. See the "FUSES" section for details.

CLEANING

If desired, the interior of the instrument may be cleaned using compressed air to dislodge any accumulated dust. (See the "TOP COVER REMOVAL" section for instructions on accessing the interior.) No other cleaning is recommended.

PCB 158G - LOW VOLTAGE POWER SUPPLY, 1/3

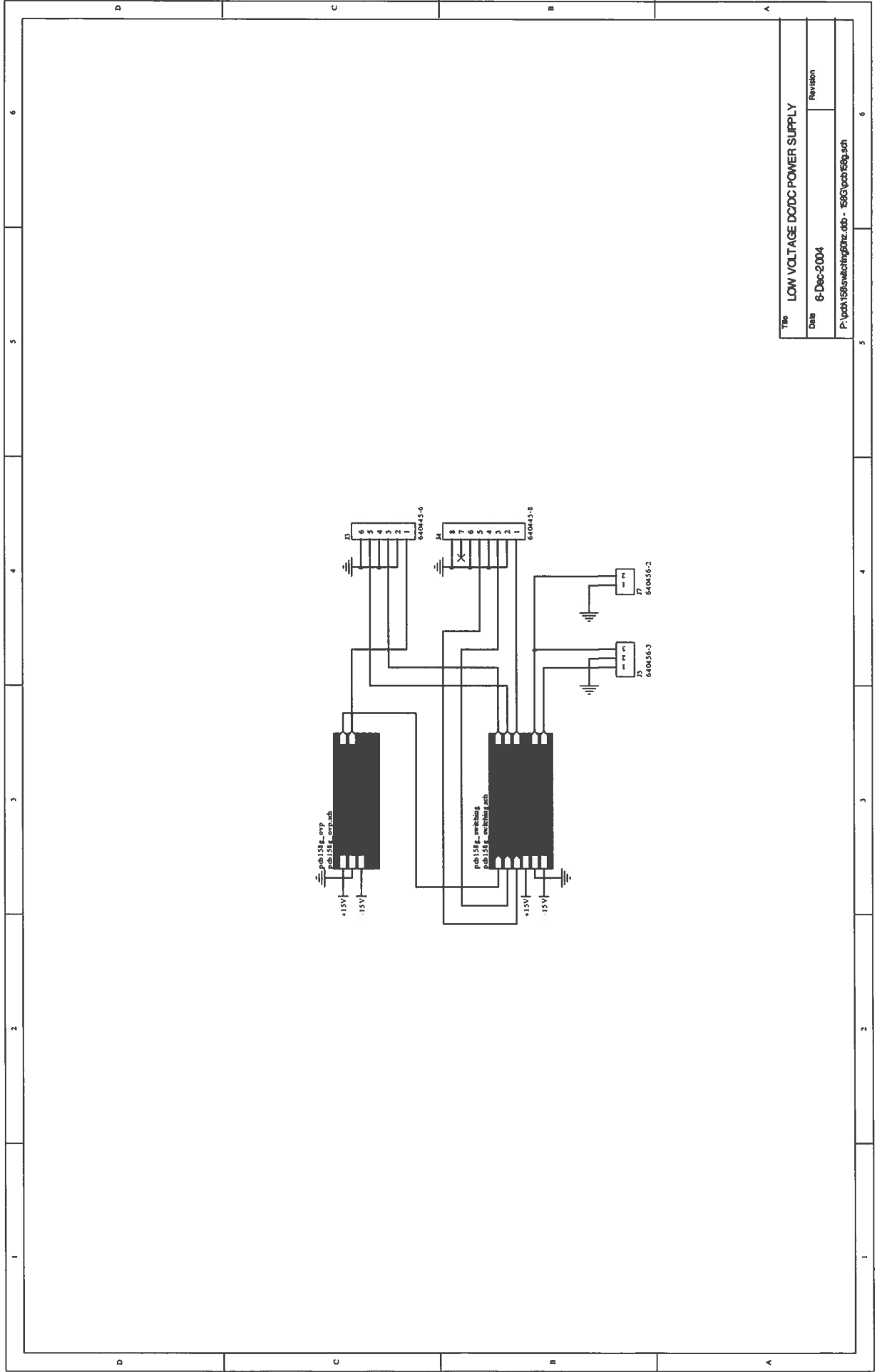

Title LOW VOLTAGE DC/DC POWER SUPPLY

Date 6-Dec-2004

Revision

P:\pcb158g\switching60hz.ddb - 158G\pcb158g.sch

PCB 158G - LOW VOLTAGE POWER SUPPLY, 2/3

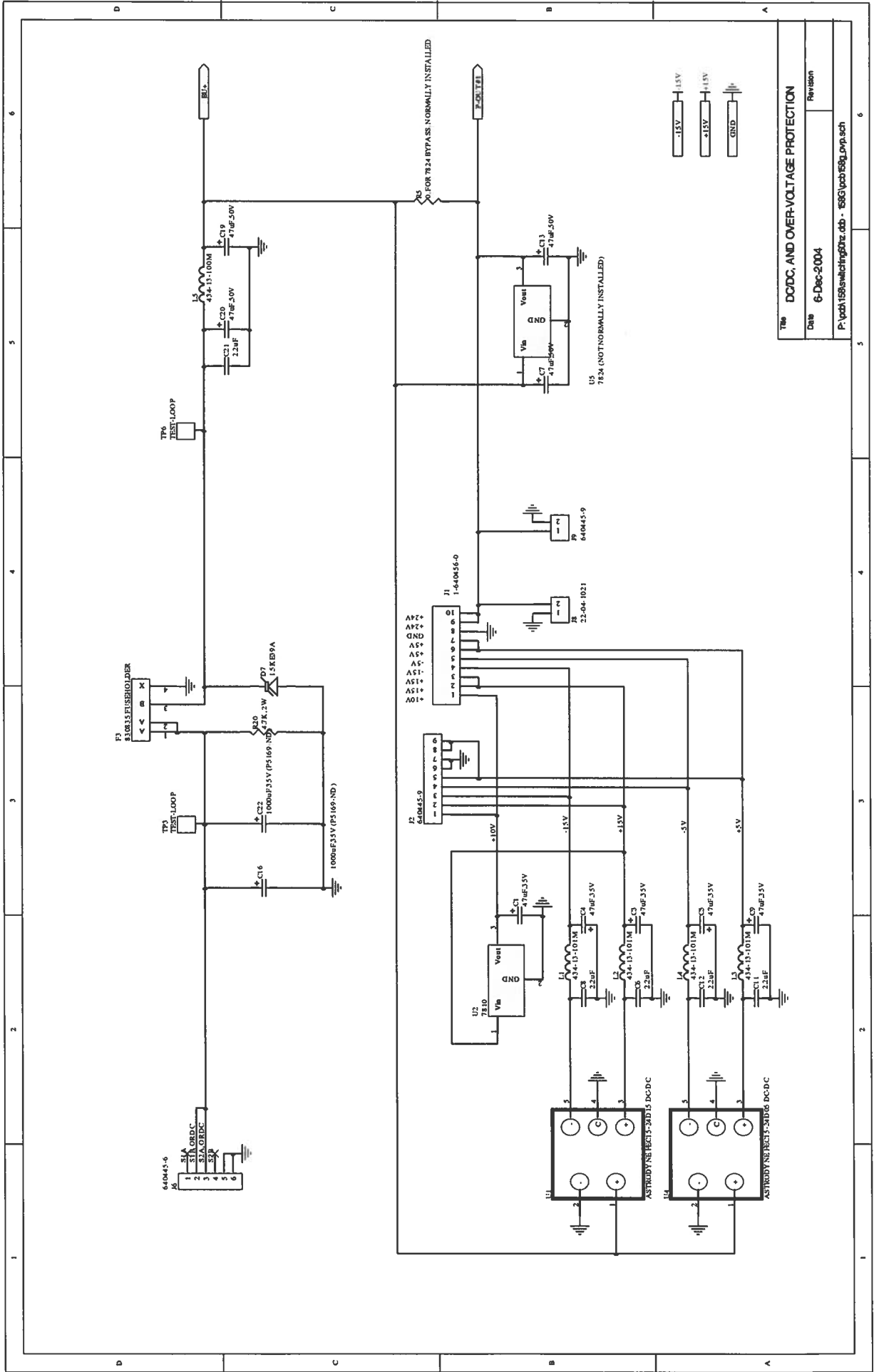

PCB 158G - LOW VOLTAGE POWER SUPPLY, 3/3

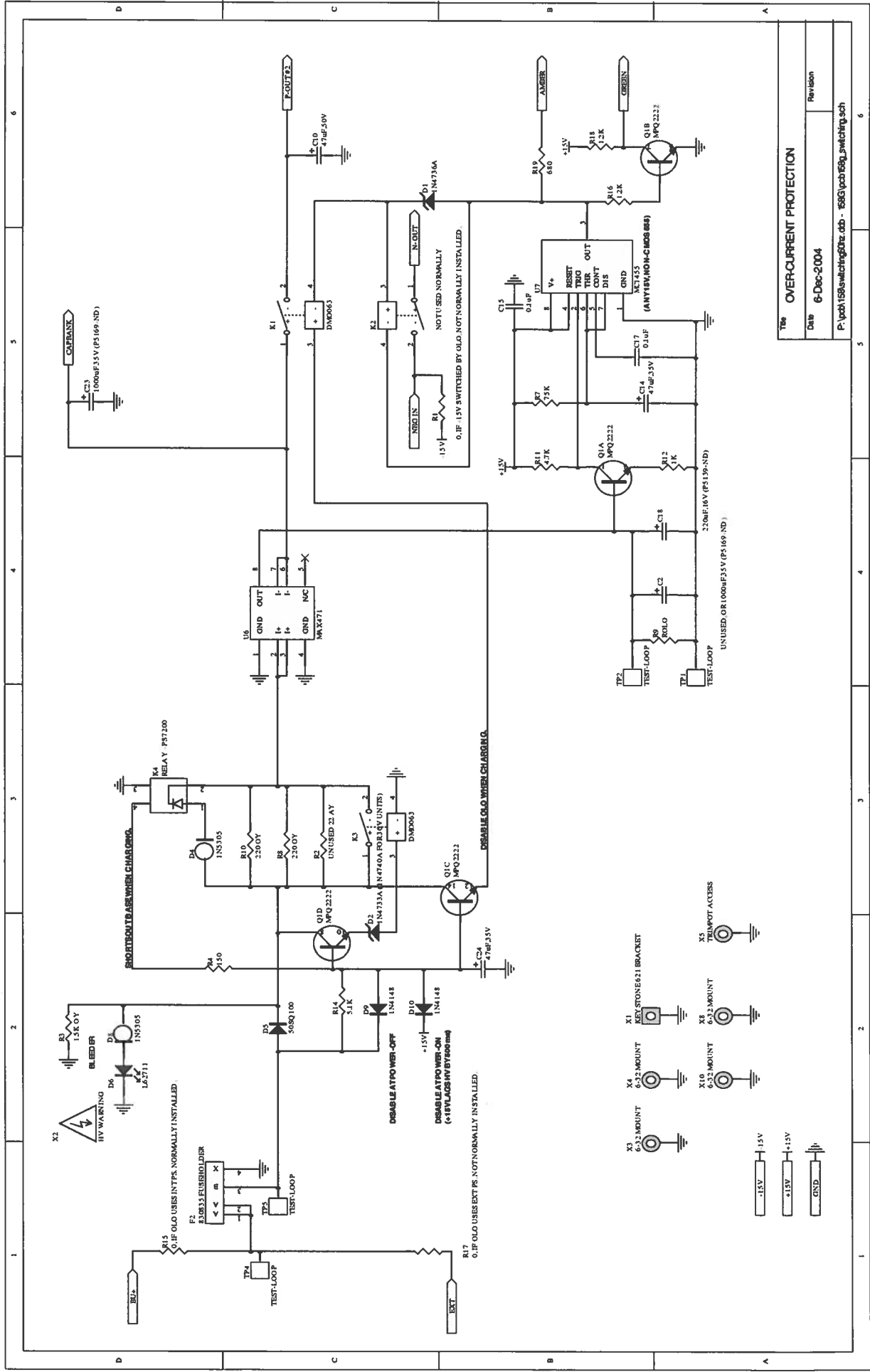

Title OVERCURRENT PROTECTION	
Date 6-Dec-2004	Revision
P:\pcb158g\switching04r.dwg - 158G\pcb158g_switching.sch	

MAIN WIRING

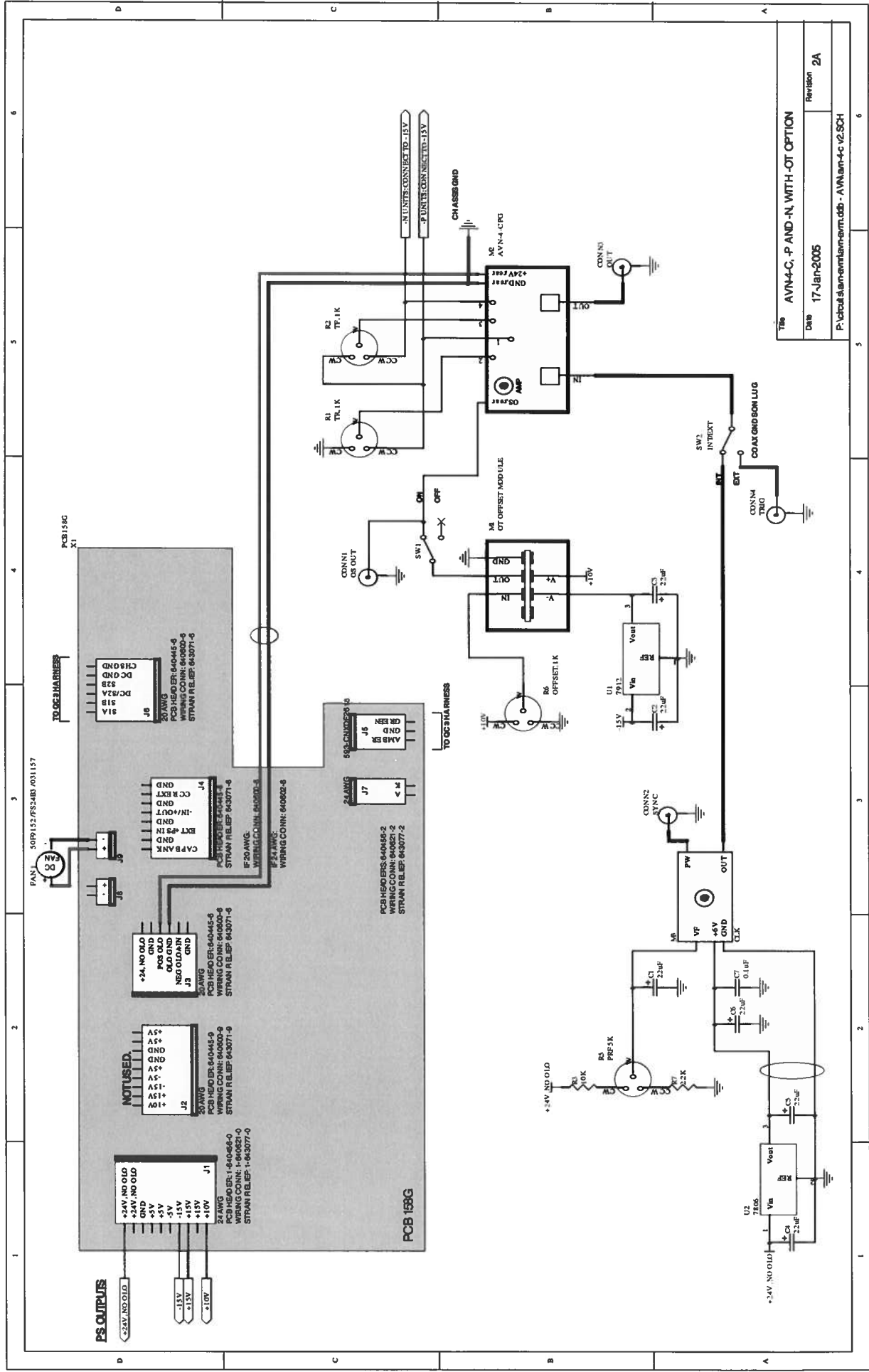

Title	AVN4-C, P AND-N, WITH-OT OPTION
Date	17-Jan-2005
Revision	2A

P:\circuit\stam-emt\main-arm.cdb - AVN4m-4c-v2.SCH

Marik 30/05