



# AVTECH ELECTROSYSTEMS LTD.

NANOSECOND WAVEFORM ELECTRONICS  
SINCE 1975

□ P.O. BOX 265  
OGDENSBURG, NY  
U.S.A. 13669-0265  
TEL: (315) 472-5270  
FAX: (613) 226-2802

TEL: 1-800-265-6681  
FAX: 1-800-561-1970  
e-mail: [info@avtechpulse.com](mailto:info@avtechpulse.com)  
<http://www.avtechpulse.com>

□ P.O. BOX 5120 STN. F  
OTTAWA, ONTARIO  
CANADA K2C 3H4  
TEL: (613) 226-5772  
FAX: (613) 226-2802

## INSTRUCTIONS

MODEL AVMM-2-C

0 TO 5 VOLTS, 25 MHz

HIGH SPEED PULSE GENERATOR

WITH 300 ps RISE TIME, 600 ps FALL TIME

SERIAL NUMBER: \_\_\_\_\_

### WARRANTY

Avtech Electrosystems Ltd. warrants products of its manufacture to be free from defects in material and workmanship under conditions of normal use. If, within one year after delivery to the original owner, and after prepaid return by the original owner, this Avtech product is found to be defective, Avtech shall at its option repair or replace said defective item. This warranty does not apply to units which have been disassembled, modified or subjected to conditions exceeding the applicable specifications or ratings. This warranty is the extent of the obligation assumed by Avtech with respect to this product and no other warranty or guarantee is either expressed or implied.

### TECHNICAL SUPPORT

Phone: 613-226-5772 or 1-800-265-6681

Fax: 613-226-2802 or 1-800-561-1970

E-mail: [info@avtechpulse.com](mailto:info@avtechpulse.com)

World Wide Web: <http://www.avtechpulse.com>

## TABLE OF CONTENTS

<b><i>WARRANTY</i></b>	<b>2</b>
<b><i>TECHNICAL SUPPORT</i></b>	<b>2</b>
<b><i>TABLE OF CONTENTS</i></b>	<b>3</b>
<b><i>INTRODUCTION</i></b>	<b>4</b>
<b><i>AVAILABLE OPTIONS</i></b>	<b>4</b>
<b><i>SPECIFICATIONS</i></b>	<b>6</b>
<b><i>INSTALLATION</i></b>	<b>7</b>
<b><i>VISUAL CHECK</i></b>	<b>7</b>
<b><i>PLUGGING IN THE INSTRUMENT</i></b>	<b>7</b>
<b><i>FRONT PANEL CONTROLS</i></b>	<b>9</b>
<b><i>Other Optional Controls</i></b>	<b>10</b>
<b><i>REAR PANEL CONTROLS (for units without -OT or -EO options)</i></b>	<b>11</b>
<b><i>REAR PANEL CONTROLS (for units with -OT or -EO options)</i></b>	<b>13</b>
<b><i>GENERAL INFORMATION</i></b>	<b>15</b>
<b><i>BASIC TEST ARRANGEMENT</i></b>	<b>15</b>
<b><i>BASIC PULSE CONTROL</i></b>	<b>16</b>
<b><i>AMPLITUDE INTERACTION</i></b>	<b>17</b>
<b><i>POLARITY INVERSION (for units without the -OT or -EO options).</i></b>	<b>17</b>
<b><i>POLARITY INVERSION (for units with the -OT or -EO options).</i></b>	<b>17</b>
<b><i>MINIMIZING WAVEFORM DISTORTIONS</i></b>	<b>18</b>
<b><i>USE 50Ω TRANSMISSION LINES AND LOADS</i></b>	<b>18</b>
<b><i>USE LOW-INDUCTANCE LOADS</i></b>	<b>18</b>
<b><i>PREVENTING DAMAGE</i></b>	<b>18</b>
<b><i>MECHANICAL INFORMATION</i></b>	<b>19</b>
<b><i>TOP COVER REMOVAL</i></b>	<b>19</b>
<b><i>ELECTROMAGNETIC INTERFERENCE</i></b>	<b>19</b>
<b><i>POWER SUPPLY AND FUSE REPLACEMENT</i></b>	<b>20</b>
<b><i>PERFORMANCE CHECK SHEET</i></b>	<b>22</b>

## INTRODUCTION

The AVMM-2-C is a high performance instrument capable of generating up to 5V into 50Ω loads at repetition rates up to 25 MHz. The output pulse width is variable from 1 to 10 ns, and the sync delay is variable up to 200 ns. The rise time is less than 300 ps, and the fall time is less than 600 ps.

Instruments with the "-P" model suffix can generate 0 to +5V, whereas instruments with the "-N" model suffix can generate 0 to -5V.

Instruments with the "-P-PN" suffix generate 0 to +5V at the main output, and are supplied with an inverting transformer that can be installed on the output to generate a negative signal.

Instruments with the "-N-PN" suffix generate 0 to -5V at the main output, and are supplied with an inverting transformer that can be installed on the output to generate a positive signal.

The output is designed to drive 50Ω loads. (A 50Ω load is required for proper operation.) The output is AC-coupled.

## AVAILABLE OPTIONS

The AVMM-2-C is available with several options:

-D Option: a 0 to 5 ns delay control is provided on the front panel.

-EA Option: the output amplitude can be controlled by an externally generated 0 to +10V analog control voltage (or by the standard front-panel controls).

-ED Option: a 0 to 5 ns delay control is provided on the front panel, and the delay can also be controlled by an externally generated 0 to +10V analog control voltage,

-EO Option: a 0 to ±5V offset control is provided on the front panel, and the offset can also be controlled by an externally generated 0 to +10V analog control voltage. The offset is internally generated.

-EW Option: the output pulse width can be controlled by an externally generated 0 to +10V analog control voltage (or by the standard front-panel controls).

-M Option: a monitor output is provided. The monitor output is a coincident attenuated (20 dB, approx) replica of the main output, and should be terminated with 50Ω.



-OT Option: a 0 to  $\pm 5V$  offset control is provided on the front panel. The offset is internally generated.

-TR Option: a 5-position rise time switch is provided on the front panel, which varies the rise time from 0.3 to 2.0 ns. This switch also affects the fall time.

## SPECIFICATIONS

Model:	AVMM-2-C <sup>1</sup>
Amplitude <sup>4</sup> : (50 Ohm load)	Variable to 5 Volts
Pulse width <sup>3</sup> :	Variable 1.0 to 10 ns
PRF:	0 to 25 MHz (-C units & modules, externally triggered) 3 kHz to 25 MHz (-C units, internally triggered)
Rise time <sup>2</sup> :	300 ps or variable 300 ps to 2.0 ns <sup>2</sup>
Fall time <sup>2</sup> :	600 ps or variable 600 ps to 2.0 ns <sup>2</sup>
Polarity <sup>5</sup> :	Positive or negative or both (specify)
Propagation delay:	≤ 30 ns (Ext trig in to pulse out)
Variable propagation delay option <sup>6</sup> :	0 to 5 ns
Jitter:	± 15 ps (Ext trig in to pulse out)
DC offset or bias insertion <sup>7</sup> :	Apply required DC offset to back-panel solder terminals (± 50 Volts, 250 mA max)
Trigger required:	Modules, and -C ext trig mode: +5 Volts, 10 ns or wider (TTL)
Sync delay:	Sync out to pulse out, -C units only: Variable 0 to 200 ns
Sync output: (-C only)	+0.5 Volts, 20 ns, will drive 50 Ohm loads
Monitor output option <sup>8</sup> :	Provides a 20 dB attenuated coincident replica of main output
Connectors:	-C: Out: SMA, Trig: BNC, Sync: BNC, Monitor: SMA
Modules:	Out: SMA In: SMA, Power: Solder terminals

- 1) -C suffix indicates stand-alone lab instrument with internal clock and line powering. No suffix indicates miniature module requiring DC power and external trigger. (See page 112 for additional details of the basic instrument formats).
- 2) For rise times variable from 300 ps to 2.0 ns via a five-position switch add suffix -TR. TR switch also affects fall time.
- 3,4,6,7) For electronic control (0 to +10V) of amplitude, pulse width, delay or offset suffix model number with -EA or -EW or -ED or EO. Electronic control units also include standard front-panel one-turn controls.
- 5) Indicate desired polarity by suffixing model number with -P or -N (i.e. positive or negative) or -P-PN or -N-PN for dual polarity option where the suffix preceding -PN indicates the polarity at the mainframe output port. (-PN available only for -C units).
- 6) Indicate delay option by suffixing model number with -D.
- 7) For internally generated DC offset (0 to ±5 V, one-turn control) add suffix -OT to model number. -OT and -EO options are not available on modules.
- 8) For monitor option add suffix -M.

## INSTALLATION

### VISUAL CHECK

After unpacking the instrument, examine to ensure that it has not been damaged in shipment. Visually inspect all connectors, knobs, and handles. Confirm that a power cord is with the instrument. If the instrument has been damaged, file a claim immediately with the company that transported the instrument.

### PLUGGING IN THE INSTRUMENT

Examine the rear of the instrument. There will be a male power receptacle, a fuse holder and the edge of the power selector card visible. Confirm that the power selector card is in the correct orientation.

For AC line voltages of 110-120V, the power selector card should be installed so that the "120" marking is visible from the rear of the instrument, as shown below:

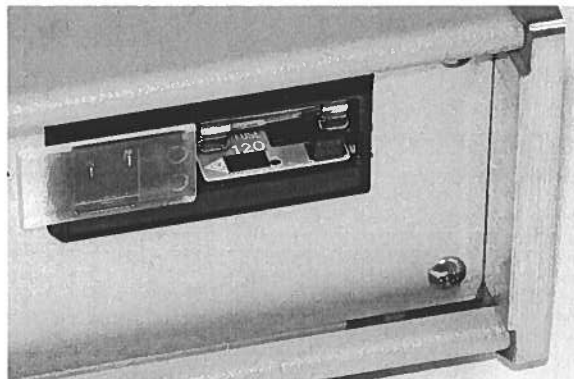

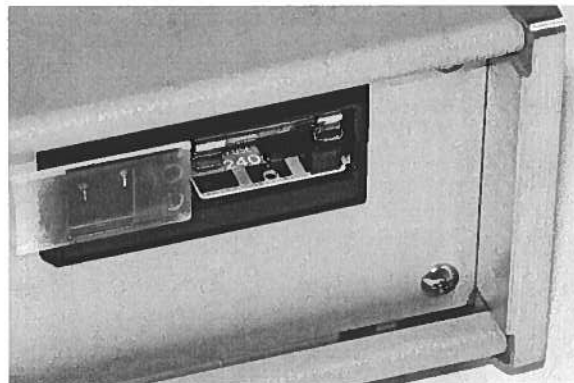

For AC line voltages of 220-240V, the power selector card should be installed so that the "240" marking is visible from the rear of the instrument, as shown below:





If it is not set for the proper voltage, remove the fuse and then grasp the card with a pair of pliers and remove it. Rotate horizontally through 180 degrees. Reinstall the card and the correct fuse.

In the 120V setting, a 0.5A slow blow fuse is required. In the 240V setting, a 0.25A slow blow fuse is required.





## FRONT PANEL CONTROLS

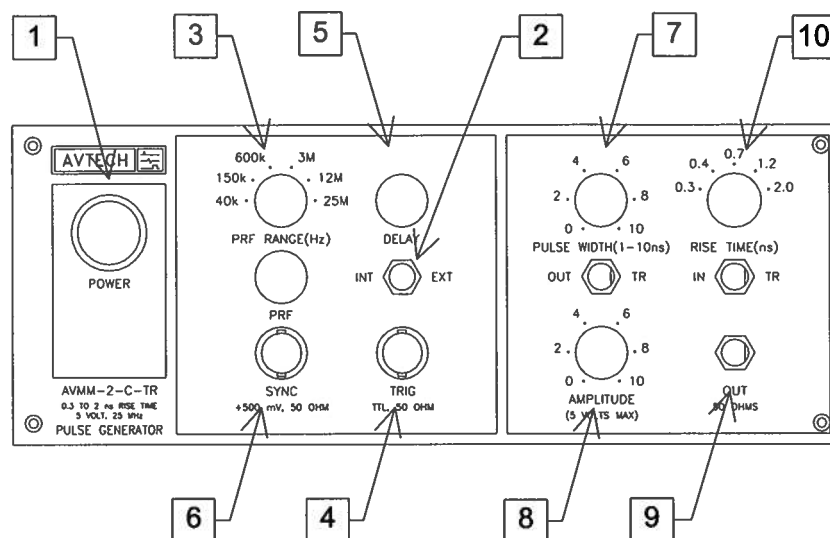

1. **POWER Switch.** The POWER push button switch applies AC prime power to the primaries of the transformer, turning the instrument on. The push button lamp is connected to the internal +15V DC supply.
2. **INT/EXT Range Switch.** If this switch is set to the "INT" position, the instrument is triggered by the internal oscillator (see item 3). If this switch is set to the "EXT" position, the instrument is triggered by a signal applied to the TRIG connector (see item 6).
3. **PRF Range Switch.** This switch sets the pulse repetition frequency (PRF) range of the internal oscillator. The marked value of each position is the upper limit of the range, approximately. The vernier dial directly below the switch varies the PRF within the set range.
4. **TRIG Connector.** When the PRF Range Switch is set to "EXT", the instrument is triggered by a TTL pulse applied to this connector. The pulse must be at least 10 ns wide. The input impedance is 50Ω.
5. **DELAY Control.** When the INT/EXT Switch is set to "INT", the main output is delayed relative to the SYNC output pulse (item 6). The delay is variable up to 200 ns, approximately, using the DELAY dial.
6. **SYNC Connector.** When the INT/EXT Switch is set to "INT", the main output is delayed relative to the output pulse on this connector (500 mV, 10 ns, will drive 50Ω). This output may be used to synchronize other equipment, such as

oscilloscopes.

7. PULSE WIDTH Control. This dial controls the pulse width.
8. AMPLITUDE Control. This dial controls the pulse amplitude.
9. OUT Connector. This is the main output. (This output *requires* a 50 $\Omega$  load to function properly).
10. RISE TIME Controls. Optional feature, present on -TR units only. The main output (item 9) has a fixed rise time of 300 ps. To vary the output rise time, the output signal must be connected using a short length of coaxial cable to the "IN TR" connector. The variable rise time output is then generated on the "OUT TR" connector. The five-position "TR" switch (0.3, 0.4, 0.7, 1.2, and 2.0 ns approximately) controls the rise time on the "OUT TR" connector.

#### Other Optional Controls

An offset dial will be present on units with the "-OT" option. This will control the DC offset present on the output, and it is variable over a 0 to  $\pm 5V$  range.

REAR PANEL CONTROLS (for units without -OT or -EO options)

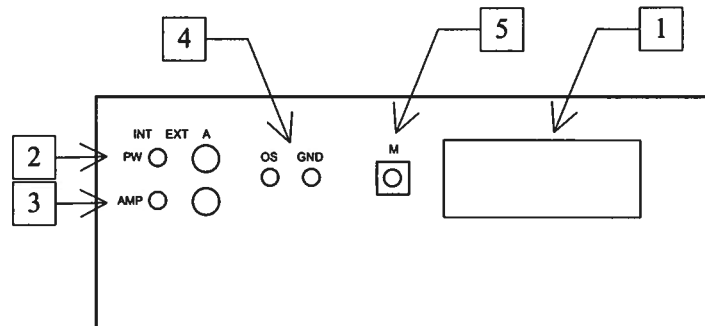

1. **AC POWER INPUT.** A three-pronged recessed male connector is provided on the back panel for AC power connection to the instrument. Also contained in this assembly is a slow-blow fuse and a removable card that can be removed and repositioned to switch between 120V AC in and 240V AC in.

For AC line voltages of 110-120V, the power selector card should be installed so that the "120" marking is visible from the rear of the instrument.

For AC line voltages of 220-240V, the power selector card should be installed so that the "240" marking is visible from the rear of the instrument.

If it is not set for the proper voltage, remove the fuse and then grasp the card with a pair of pliers and remove it. Rotate horizontally through 180 degrees. Reinstall the card and the correct fuse.

In the 120V setting, a 0.5A slow blow fuse is required. In the 240V setting, a 0.25A slow blow fuse is required. See the "Installation" section for more details.

2. **PW INT/EXT SWITCH AND CONNECTOR (Optional, -EW units only).** To control the pulse width of the output with an external DC voltage, set the two-position switch to the EXT position and apply 0 to +10V to the BNC Connector ( $R_{IN} \geq 10 \text{ k}\Omega$ ). When this switch is in the "INT" position, the pulse width is controlled by the front-panel controls.
3. **AMP INT/EXT SWITCH AND CONNECTOR (Optional, -EA units only).** To control the amplitude of the output with an external DC voltage, set the two-position switch to the EXT position and apply 0 to +10V to the BNC Connector ( $R_{IN} \geq 10 \text{ k}\Omega$ ). When this switch is in the "INT" position, the amplitude is controlled by the front-panel controls.
4. **OS INPUT.** To add a DC offset the output pulse, connect a DC power supply set to the desired offset value to these terminals. The maximum allowable DC offset voltage is  $\pm 50$  Volts. When not used, this input should be connected to the adjacent

ground terminal.

5. MONITOR Outputs (Optional, -M units only). Provides an attenuated ( $\div 10$ , approximately) coincident replica (to 50 Ohms) of the main output.

### REAR PANEL CONTROLS (for units with -OT or -EO options)

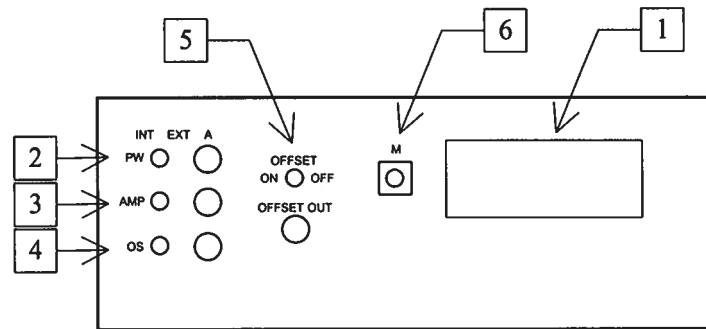

1. **AC POWER INPUT.** A three-pronged recessed male connector is provided on the back panel for AC power connection to the instrument. Also contained in this assembly is a slow-blow fuse and a removable card that can be removed and repositioned to switch between 120V AC in and 240V AC in.

For AC line voltages of 110-120V, the power selector card should be installed so that the "120" marking is visible from the rear of the instrument.

For AC line voltages of 220-240V, the power selector card should be installed so that the "240" marking is visible from the rear of the instrument.

If it is not set for the proper voltage, remove the fuse and then grasp the card with a pair of pliers and remove it. Rotate horizontally through 180 degrees. Reinstall the card and the correct fuse.

In the 120V setting, a 0.5A slow blow fuse is required. In the 240V setting, a 0.25A slow blow fuse is required. See the "Installation" section for more details.

2. **PW INT/EXT SWITCH AND CONNECTOR (Optional, -EW units only).** To control the pulse width of the output with an external DC voltage, set the two-position switch to the EXT position and apply 0 to +10V to the BNC Connector ( $R_{IN} \geq 10 \text{ k}\Omega$ ). When this switch is in the "INT" position, the pulse width is controlled by the front-panel controls.
3. **AMP INT/EXT SWITCH AND CONNECTOR (Optional, -EA units only).** To control the amplitude of the output with an external DC voltage, set the two-position switch to the EXT position and apply 0 to +10V to the BNC Connector ( $R_{IN} \geq 10 \text{ k}\Omega$ ). When this switch is in the "INT" position, the amplitude is controlled by the front-panel controls.

4. OS INT/EXT SWITCH AND CONNECTOR (Optional, -EO units only). To control the offset of the output with an external DC voltage, set the two-position switch to the EXT position and apply 0 to +10V to the BNC Connector ( $R_{IN} \geq 10 \text{ k}\Omega$ ). When this switch is in the "INT" position, the offset is controlled by the front-panel controls.
5. OFFSET ON/OFF SWITCH & OUTPUT (Optional, -EO and -OT units only). This switch enables the offset feature when it is set to "ON". When it is set to "OFF", no offset is added to the output. The internally generated offset is available at the "OFFSET OUT" BNC connector, for monitoring purposes. To add an offset to inverted pulses on AVMM units with the dual polarity option (-PN), connect this terminal to the DC terminal of the AVX-2-T inverting transformer (see the "POLARITY INVERSION" sections in this manual for further details).
6. MONITOR Outputs (Optional, -M units only). Provides an attenuated ( $\div 10$ , approximately) coincident replica (to 50 Ohms) of the main output.

## GENERAL INFORMATION

### BASIC TEST ARRANGEMENT

The AVMM-2-C should be tested with a sampling oscilloscope with a bandwidth of at least 5 GHz to properly observe the high-speed waveform. A typical test arrangement is shown below:

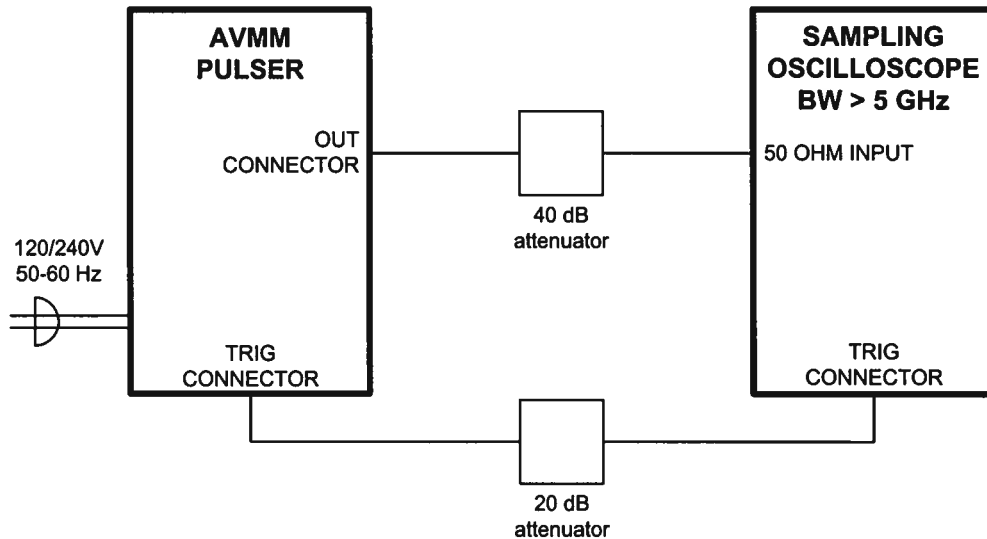

ALL CABLES: 50 OHM COAXIAL

The attenuators are required to prevent damage to the sampling oscilloscope. A 40 dB attenuator with sufficient voltage rating should be used on the main output.

Models with the -TR option require a different setup, to enable the -TR feature:

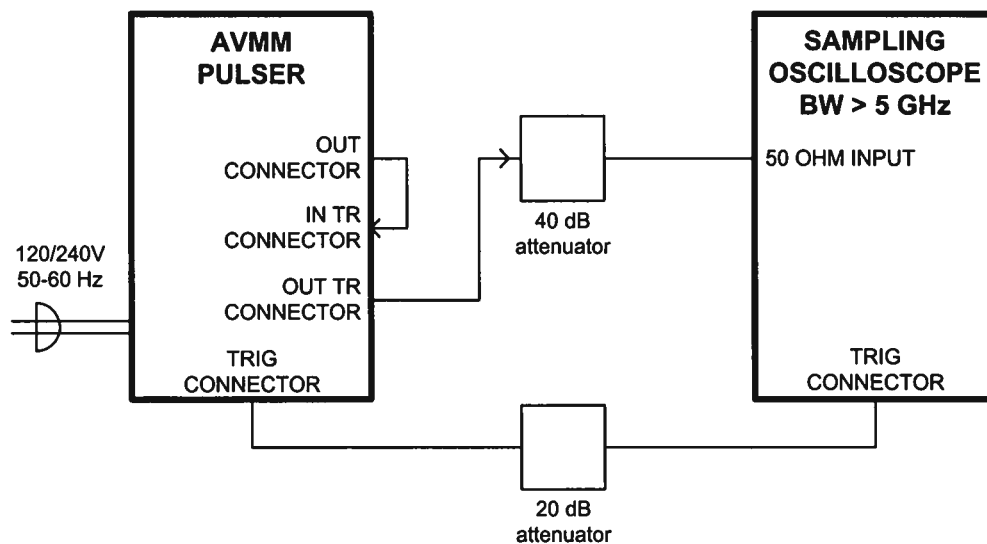

ALL CABLES: 50 OHM COAXIAL

## BASIC PULSE CONTROL

This instrument can be triggered by its own internal clock or by an external TTL trigger signal. When triggered internally, two mainframe output channels respond to the trigger: OUT and SYNC.

- OUT. This is the main output.
- SYNC. The SYNC pulse is a 500 mV, 10 ns reference pulse used to trigger oscilloscopes or other measurement systems.

These pulses are illustrated below:

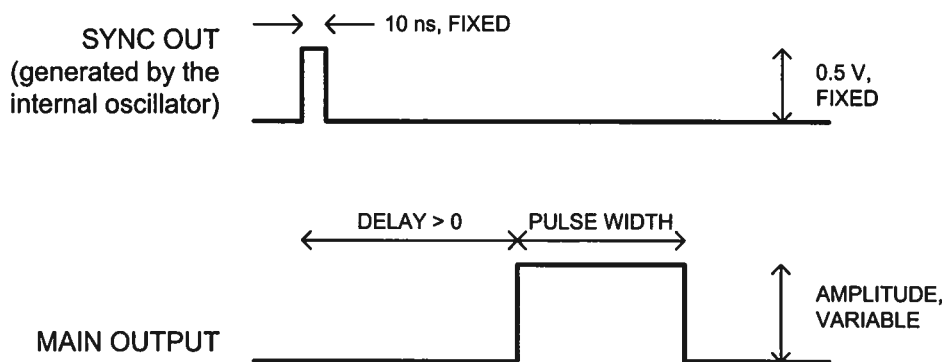

*Figure A*

When triggered externally, the TRIG connector is used as an input. The delay controls do not function in this mode. Figure B illustrates this mode:

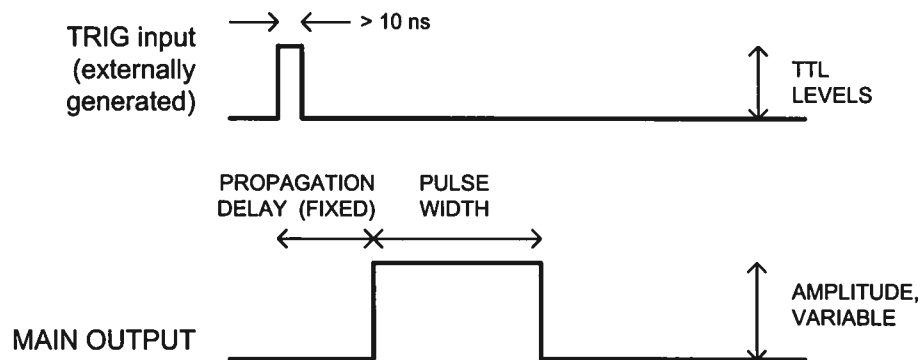

*Figure B*



## AMPLITUDE INTERACTION

Some properties of the output pulse may change as a function of the amplitude setting. For some demanding applications, it may be desirable to use a combination of external attenuators and the amplitude pot to achieve the desired output amplitude.

### POLARITY INVERSION (for units without the -OT or -EO options).

To invert the output of the AVMM unit, connect the supplied AVX-2-T inverting transformers to the OUT port. An inverted pulse is then obtained at the OUT port of the AVX-2-T unit.

To add an offset to the inverted pulse, apply the required DC level to the DC terminal of the AVX-2-T unit, not to the rear-panel terminal on the mainframe.

### POLARITY INVERSION (for units with the -OT or -EO options).

To invert the output of the AVMM unit, connect the supplied AVX-2-T inverting transformers to the OUT port. An inverted pulse is then obtained at the OUT port of the AVX-2-T unit.

To add an offset to the inverted pulse, connect a lead from the rear-panel "OFFSET OUT" BNC connector to the DC terminal of the AVX-2-T unit. The DC offset at the output of the AVX-2-T unit is then controlled by the front panel OFFSET control.

## MINIMIZING WAVEFORM DISTORTIONS

### USE 50Ω TRANSMISSION LINES AND LOADS

Connect the load to the pulse generator with 50Ω transmission lines (e.g. RG-58 or RG-174 cable).

This instrument requires a 50Ω load for proper operation. It will not properly drive a high-impedance load. The output stage will be damaged if it is operated into an open circuit (or any other high impedance). Failures due to improper output loading are not covered by the warranty.

### USE LOW-INDUCTANCE LOADS

Lenz's Law predicts that for an inductive voltage spike will be generated when the current through an inductance changes. Specifically,  $V_{\text{SPIKE}} = L \times di_{\text{LOAD}}/dt$ , where L is the inductance,  $i_{\text{LOAD}}$  is the load current change, and t is time. For this reason, it is important to keep any parasitic in the load low. This means keeping wiring short, and using low inductance components. In particular, wire-wound resistors should be avoided.

## PREVENTING DAMAGE

The AVMM-2-C may fail if triggered at a PRF greater than 25 MHz.

This unit is designed to operate into a load impedance of 50 Ohms and the output stage will be damaged if it is operated into an open circuit (or any other high impedance). Failures due to improper output loading are not covered by the warranty.

The lifetime of the switching elements in the pulse generator module is proportional to the running time of the instrument. For this reason the prime power to the instrument should be turned off when the instrument is not in use.

## MECHANICAL INFORMATION

### TOP COVER REMOVAL

The interior of the instrument may be accessed by removing the four Phillips screws on the top panel. With the four screws removed, the top cover may be slid back (and off).

### ELECTROMAGNETIC INTERFERENCE

To prevent electromagnetic interference with other equipment, all used outputs should be connected to shielded  $50\Omega$  loads using shielded  $50\Omega$  coaxial cables. Unused outputs should be terminated with shielded  $50\Omega$  BNC terminators or with shielded BNC dust caps, to prevent unintentional electromagnetic radiation. All cords and cables should be less than 3m in length.

## POWER SUPPLY AND FUSE REPLACEMENT

This instrument has three main fuses, plus two spares. One, which protects the AC input, is located in the rear-panel power entry module, as described in the "Rear Panel Controls" section of this manual. If the power appears to have failed, check the AC fuse first.

The other two fuses (plus two spares) are located on the internal DC power supply, as shown below:

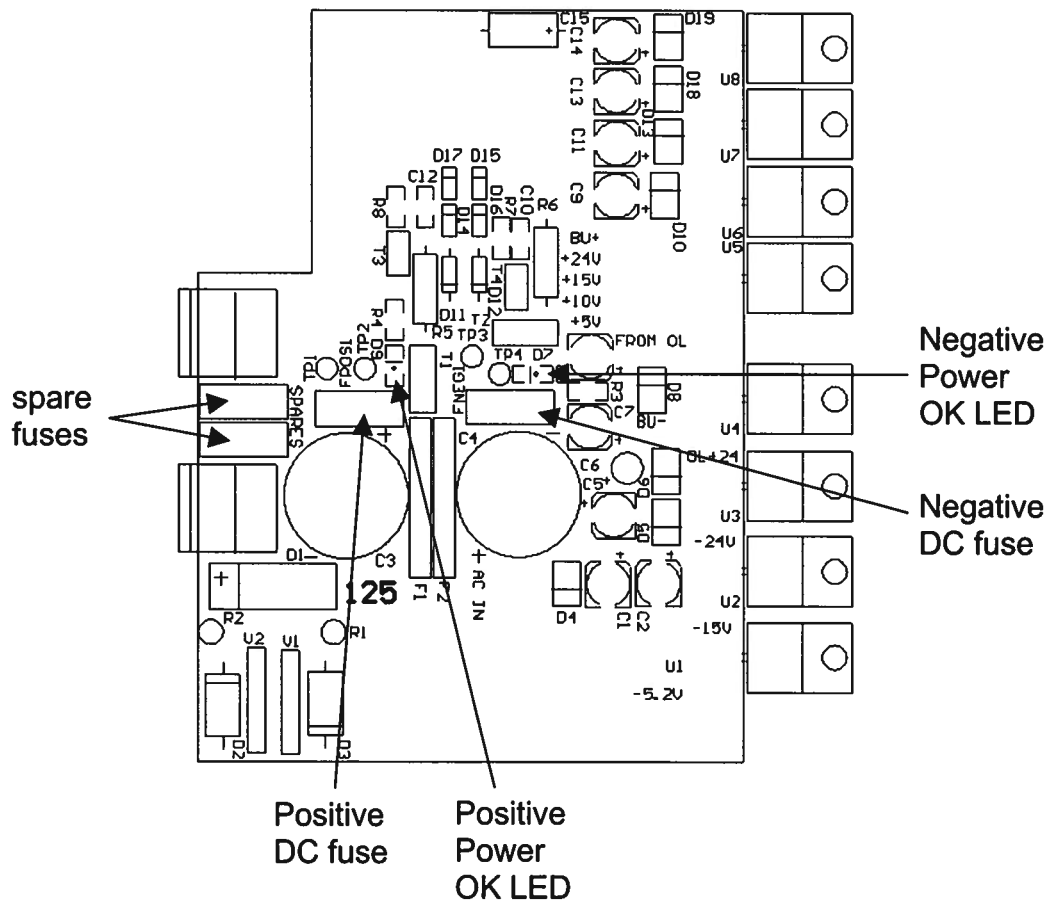

The positive fuse and one of the spare fuses on this circuit board are 1A slow-blow fuses, Littlefuse part number R452001. (This fuse can be ordered from Digikey, [www.digikey.com](http://www.digikey.com). The Digikey part number is F1343CT-ND). The negative fuse and the second spare fuse are 0.5A slow-blow fuses (Littlefuse R452.500, Digikey part number F1341CT-ND).

If you suspect that the DC fuses are blown, follow this procedure:

1. Remove the top cover, by removing the four Phillips screws on the top cover and then sliding the cover back and off.

2. Locate the two "Power OK" LEDs on the power supply circuit board, as illustrated above.
3. Turn on the instrument.
4. Observe the "Power OK" LEDs. If the fuses are not blown, the two LEDs will be lit (bright red). If one of the LEDs is not lit, the fuse next to it has blown.
5. Turn off the instrument.
6. If a fuse is blown, use needle-nose pliers to remove the blown fuse from its surface-mount holder.
7. Replace the fuse. (Spare 1 Amp and 0.5 Amp fuses are provided on the circuit board. They may be transferred to the active fuse locations using needle-nose pliers.)

Aug 12/02