



**AVTECH ELECTROSYSTEMS LTD.**

NANOSECOND WAVEFORM ELECTRONICS  
SINCE 1975

P.O. BOX 265  
OGDENSBURG, NY  
U.S.A. 13669-0265  
TEL: (315) 472-5270  
FAX: (613) 226-2802

TEL: 1-800-265-6681  
FAX: 1-800-561-1970

e-mail: [info@avtechpulse.com](mailto:info@avtechpulse.com)  
<http://www.avtechpulse.com>

P.O. BOX 5120 STN. F  
OTTAWA, ONTARIO  
CANADA K2C 3H4  
TEL: (613) 226-5772  
FAX: (613) 226-2802

## INSTRUCTIONS

**MODEL AVMM-3-C-PN-ED PULSE GENERATOR**

**S.N.:**

### WARRANTY

Avtech Electrosystems Ltd. warrants products of its manufacture to be free from defects in material and workmanship under conditions of normal use. If, within one year after delivery to the original owner, and after prepaid return by the original owner, this Avtech product is found to be defective, Avtech shall at its option repair or replace said defective item. This warranty does not apply to units which have been disassembled, modified or subjected to conditions exceeding the applicable specifications or ratings. This warranty is the extent of the obligation assumed by Avtech with respect to this product and no other warranty or guarantee is either expressed or implied.

### TECHNICAL SUPPORT

Phone: 613-226-5772 or 1-800-265-6681

Fax: 613-226-2802 or 1-800-561-1970

E-mail: [info@avtechpulse.com](mailto:info@avtechpulse.com)

World Wide Web: <http://www.avtechpulse.com>

TABLE OF CONTENTS

WARRANTY .....	2
TABLE OF CONTENTS .....	3
FIG. 1: PULSE GENERATOR TEST ARRANGEMENT.....	4
GENERAL OPERATING INSTRUCTIONS .....	5
FIG. 2: FRONT PANEL CONTROLS .....	7
FRONT PANEL CONTROLS .....	8
FIG. 3: BACK PANEL CONTROLS.....	10
BACK PANEL CONTROLS.....	11
POWER SUPPLY AND FUSE REPLACEMENT .....	12
PERFORMANCE CHECK SHEET .....	14

FIG. 1: PULSE GENERATOR TEST ARRANGEMENT

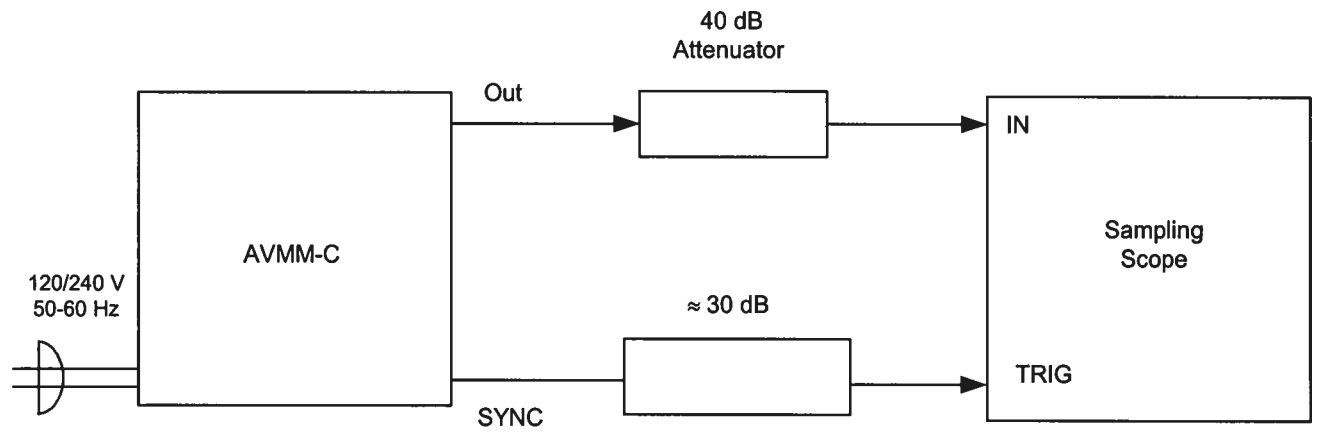

## GENERAL OPERATING INSTRUCTIONS

- 1) The bandwidth capability of components and instruments used to display the pulse generator output signal (attenuators, cables, connectors, etc.) should exceed 5 gigahertz.
- 2) The use of 40 db attenuator at the sampling scope vertical input channel will insure a peak input signal to the sampling scope of less than one volt.
- 3) The SYNC output channel provides a +500 mV 10 ns pulse.
- 4) To obtain a stable output display the PRF control on the front panel should be set mid-range while the PRF range switch may be in either range. The front panel TRIG toggle switch should be in the INT position. The front panel DELAY control and the scope triggering controls are then adjusted to obtain a stable output. It is recommended that the DELAY control first be set max counter clockwise and then turned clockwise until a stable display is obtained. The scope may then be used to set the desired PRF by rotating the PRF control and by means of the PRF range switch. The stability of the display on some sampling scopes is very sensitive to the trigger delay setting, particularly at high PRF (e.g. 10 to 25 MHz). If necessary, consult your sample scope instructions manual for the proper triggering method.
- 5) The output pulse width is controlled by means of the front panel one turn PW control. The control should initially be set maximum clockwise and the pulse width adjusted using an oscilloscope. Rotation of the PW pot causes the position of the falling edge of the pulse to change. For the PRF range of 0 to 25 MHz, the output pulse width is variable over the range of 0 to 5 ns. CAUTION: The output pulse width is PRF-dependent and so the PW reading given by the dial will not be valid at all PRF settings.
- 6) The output pulse amplitude is controlled by means of the front panel one turn AMP control.
- 7) To DC offset the output pulse connect a DC power supply set to required DC offset value to the back panel terminals marked O.S. The maximum attainable DC offset voltage is  $\pm 50$  volts (for units without the OT or EO option only).

- 8) The AVM output pulse position or propagation delay can be varied for up to 5ns by means of the DELAY Tp control. Rotating the Tp control clockwise increases the delay (-D option).
- 9) To voltage control the propagation delay, set the rear panel switch in the EXT position and apply 0 to +10V to connector A ( $R_{IN} > 10K$ ). (-ED option).
- 10) An external clock may be used to control the output PRF of the unit by setting the front panel TRIG toggle switch in the EXT position and applying a 10 ns (or wider) TTL level pulse to the TRIG BNC connector input. The AVMM unit triggers on the rising edge of the input trigger pulse. For operation in this mode, the scope time base must also be triggered by the external clock rather than from the TRIG output.
- 11) WARNING: Model AVMM-C may fail if triggered at a PRF greater than 25.0 MHz.
- 12) The Model AVMM-C pulse generator can withstand an infinite VSWR on the output port.
- 13) Dual Polarity Option. To invert the output of the AVMM unit, connect the AVX-2-T unit to the OUT port. An inverted pulse is then obtained at the OUT port of the AVX-2-T unit. To offset the inverted pulse, apply the desired DC potential to the DC terminal on the AVX-2-T module. Note that a male-to-male SMA sex changer must be used to connect the AVX-2-T module to the OUT SMA terminal.
- 14) The AVMM-C unit can be converted from 120 to 240V 50-60 Hz operation by adjusting the voltage selector card in the rear panel fused voltage selector-cable connector assembly.
- 15) For additional assistance:

Tel: (613) 226-5772

Fax: (613) 226-2802

Email: [info@avtechpulse.com](mailto:info@avtechpulse.com)

FIG. 2: FRONT PANEL CONTROLS

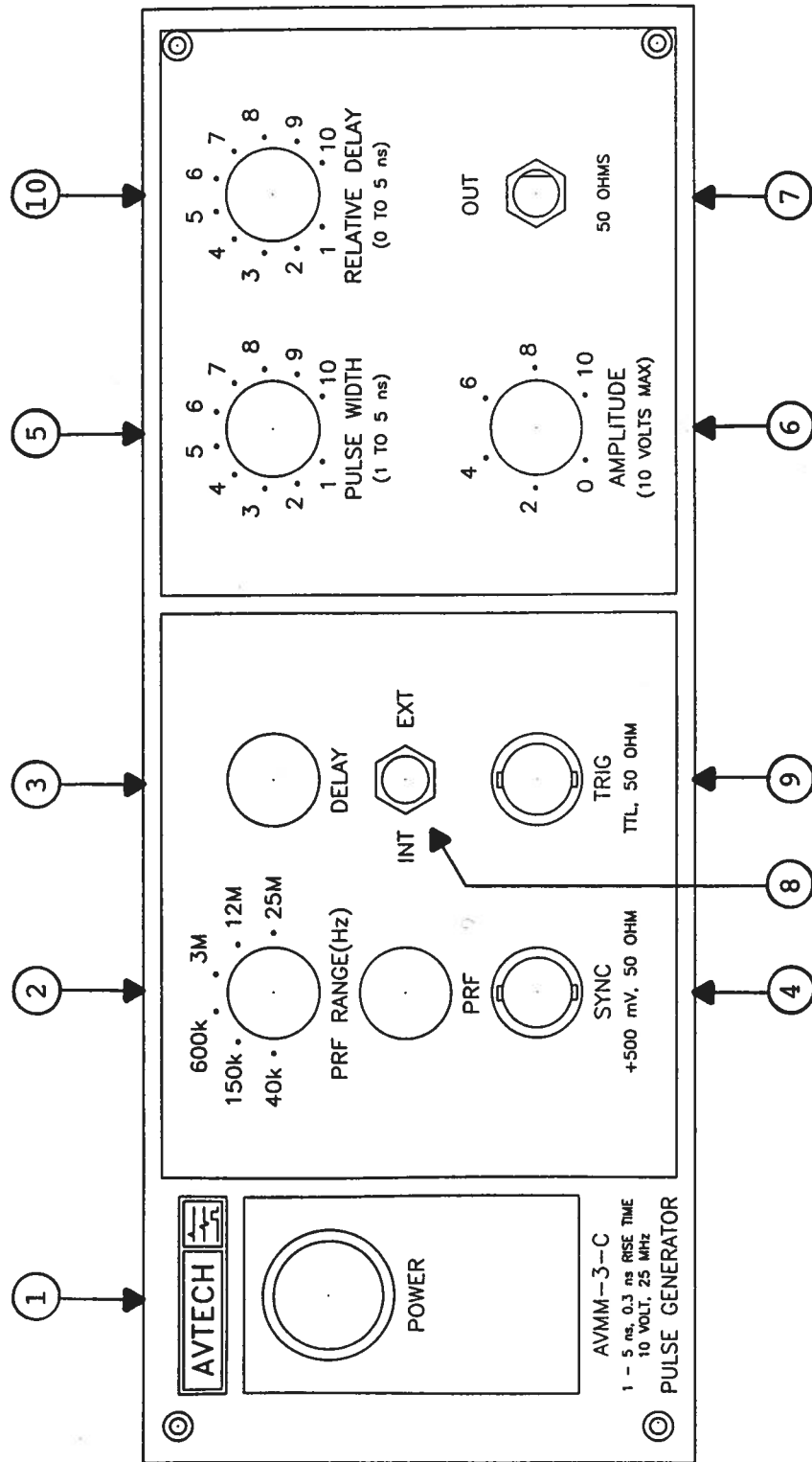

## FRONT PANEL CONTROLS

- (1) ON-OFF Switch. Applies basic prime power to all stages.
- (2) PRF Control. PRF RANGE and PRF controls determine output PRF as follows:

	PRF MIN	PRF MAX
Range 1	10 kHz	40 kHz
Range 2	40 kHz	150 kHz
Range 3	150 kHz	600 kHz
Range 4	600 kHz	3.0 MHz
Range 5	3.0 MHz	12 MHz
Range 6	12 MHz	25 MHz

- (3) DELAY Control. Controls the relative delay between the reference output pulse provided at the SYNC output (4) and the main output (7). This delay is variable over the range of 0 to at least 100 ns.
- (4) SYNC Output. This output precedes the main output (7) and is used to trigger the sampling scope time base. The output is a 500 mV 10 ns (approx.) pulse capable of driving a fifty-Ohm load.
- (5) PW Control. A one-turn control which varies the output pulse width.
- (6) AMP Control. A one-turn control, which varies the output pulse amplitude from 0 to max output to a fifty-Ohm load.
- (7) OUT Connector. SMA connector provides 300 ps rise time output to a fifty-Ohm load.
- (8) EXT-INT Control. With this toggle switch in the INT position, the PRF of the AVMM unit is controlled via an internal clock, which in turn is controlled by the PRF controls. With the toggle switch in the EXT position, the AVMM unit requires a 10 ns (or wider) TTL level pulse applied at the TRIG input in order to trigger the output stages. In addition, in this mode, the scope time base must be triggered by the external trigger source.
- (9) TRIG IN. When the INT-EXT switch is in the EXT position, a TTL level trigger pulse is applied to the BNC connector.



- (10) The AVMM output pulse position or propagation delay can be varied for up to 5 ns by means of the DELAY Tp control. Rotating the Tp control clockwise increases the delay (-D option).

FIG. 3: BACK PANEL CONTROLS

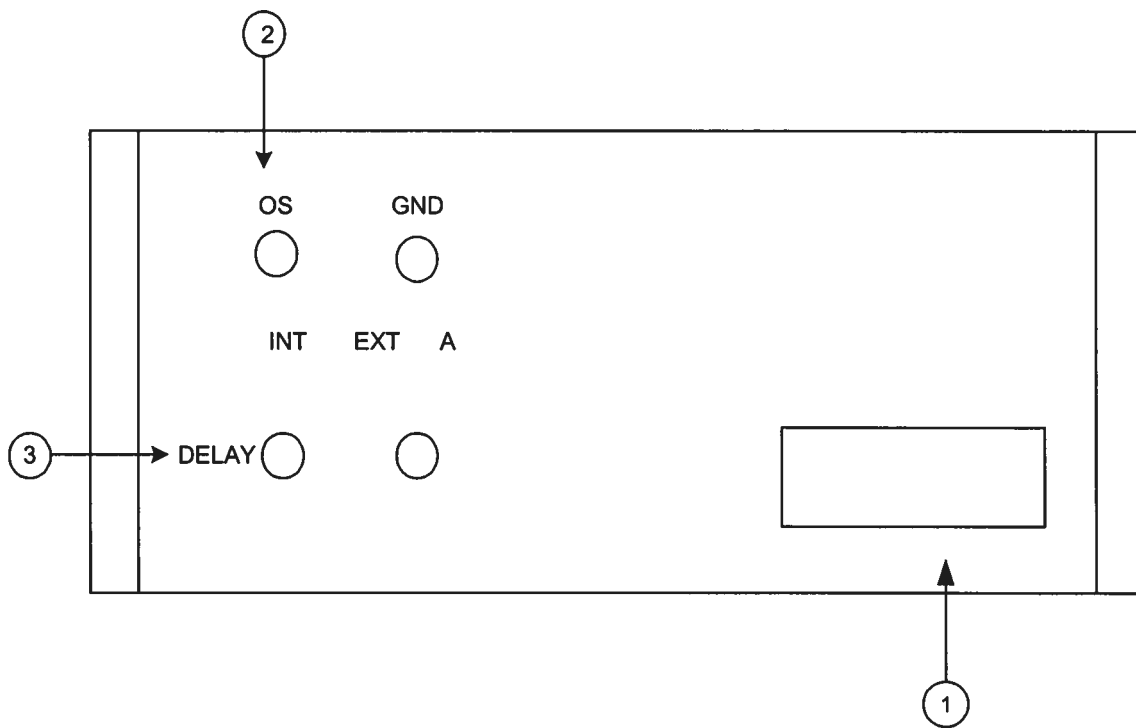

## BACK PANEL CONTROLS

- (1) FUSED CONNECTOR, VOLTAGE SELECTOR. The detachable power cord is connected at this point. In addition, the removable cord is adjusted to select the desired input operating voltage. The unit also contains the main power fuse.

For AC line voltages of 110-120V, the power selector card should be installed so that the "120" marking is visible from the rear of the instrument.

For AC line voltages of 220-240V, the power selector card should be installed so that the "240" marking is visible from the rear of the instrument.

If it is not set for the proper voltage, remove the fuse and then grasp the card with a pair of pliers and remove it. Rotate horizontally through 180 degrees. Reinstall the card and the correct fuse.

In the 120V setting, a 0.5A slow blow fuse is required. In the 240V setting, a 0.25A slow blow fuse is required.

- (2) DC OFFSET Input. To DC offset the output pulse, connect a DC power supply set to the desired offset value to these terminals. The maximum allowable DC offset voltage is  $\pm 50$  Volts ( $\pm 250$  mA).
- (3) DELAY. To voltage control the propagation delay, set the switch in the EXT position and apply 0 to +10V to connector A ( $R_{IN} > 10K$ ). (-ED option).

## POWER SUPPLY AND FUSE REPLACEMENT

This instrument has three main fuses, plus two spares. One, which protects the AC input, is located in the rear-panel power entry module, as described in the “Rear Panel Controls” section of this manual. If the power appears to have failed, check the AC fuse first.

The other two fuses (plus two spares) are located on the internal DC power supply, as shown below:

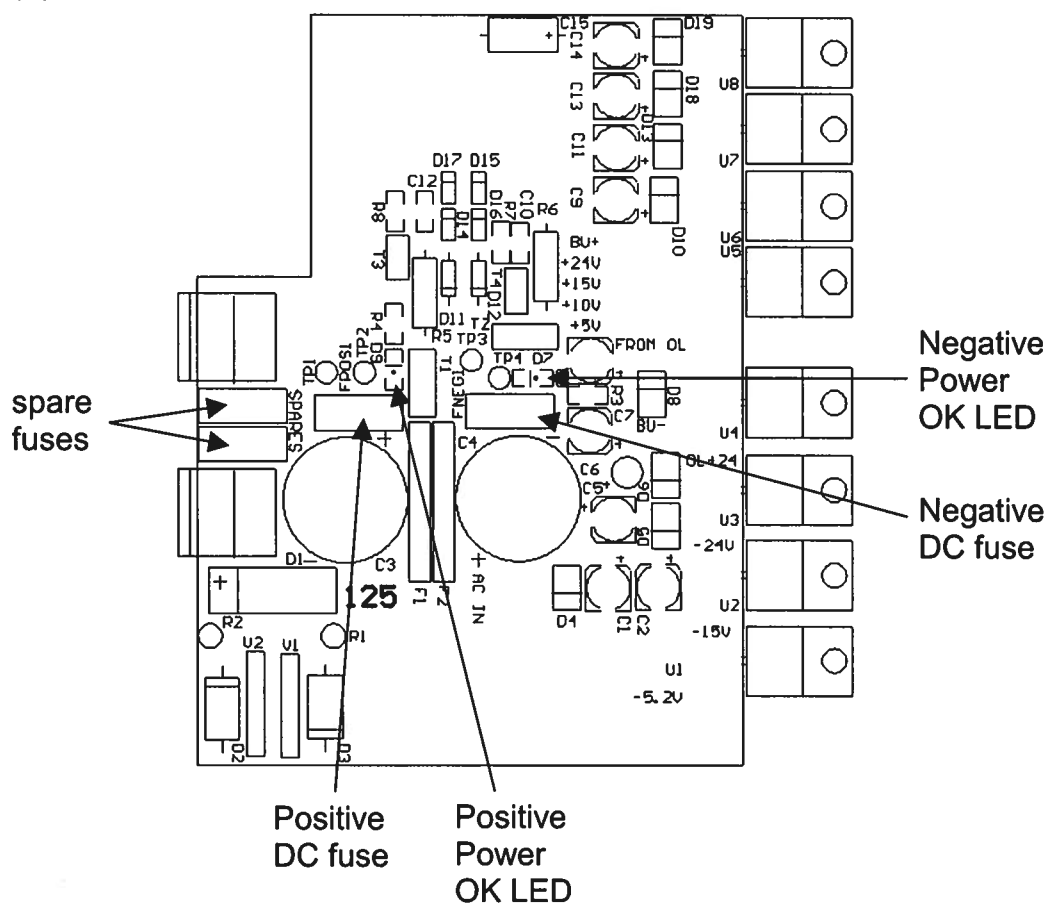

The four fuses on this circuit board are 0.5A slow-blow fuses, Littlefuse part number R452.500. (This fuse can be ordered from Digikey, [www.digikey.com](http://www.digikey.com). The Digikey part number is F1341CT-ND).

If you suspect that the DC fuses are blown, follow this procedure:

1. Remove the top cover, by removing the four Phillips screws on the top cover and then sliding the cover back and off.
2. Locate the two "Power OK" LEDs on the power supply circuit board, as illustrated above.
3. Turn on the instrument.
4. Observe the "Power OK" LEDs. If the fuses are not blown, the two LEDs will be lit (bright red). If one of the LEDs is not lit, the fuse next to it has blown.
5. Turn off the instrument.
6. If a fuse is blown, use needle-nose pliers to remove the blown fuse from its surface-mount holder.
7. Replace the fuse. (Two spare 0.5 Amp fuses are provided on the circuit board. They may be transferred to the active fuse locations using needle-nose pliers.)

February 15/2002  
(edition 1)