



# AVTECH ELECTROSYSTEMS LTD.

NANOSECOND WAVEFORM ELECTRONICS  
SINCE 1975

□ P.O. BOX 265  
OGDENSBURG, NY  
U.S.A. 13669-0265  
TEL: (315) 472-5270  
FAX: (613) 226-2802

TEL: 1-800-265-6681  
FAX: 1-800-561-1970

e-mail: [info@avtechpulse.com](mailto:info@avtechpulse.com)  
<http://www.avtechpulse.com>

□ P.O. BOX 5120 STN. F  
OTTAWA, ONTARIO  
CANADA K2C 3H4  
TEL: (613) 226-5772  
FAX: (613) 226-2802

## INSTRUCTIONS

MODEL AVO-2L-P-IMRA2-EA-EW-D PULSE GENERATOR

S.N.:

### WARRANTY

Avtech Electrosystems Ltd. warrants products of its manufacture to be free from defects in material and workmanship under conditions of normal use. If, within one year after delivery to the original owner, and after prepaid return by the original owner, this Avtech product is found to be defective, Avtech shall at its option repair or replace said defective item. This warranty does not apply to units which have been disassembled, modified or subjected to conditions exceeding the applicable specifications or ratings. This warranty is the extent of the obligation assumed by Avtech with respect to this product and no other warranty or guarantee is either expressed or implied.

### TECHNICAL SUPPORT

Phone: 613-226-5772 or 1-800-265-6681

Fax: 613-226-2802 or 1-800-561-1970

E-mail: [info@avtechpulse.com](mailto:info@avtechpulse.com)

World Wide Web: <http://www.avtechpulse.com>

TABLE OF CONTENTS

|   |   |
|---|---|
| WARRANTY .....  | 2 |
| TABLE OF CONTENTS .....   | 3 |
| FIG. 1: PULSE GENERATOR TEST ARRANGEMENT.....                       | 4 |
| GENERAL OPERATING INSTRUCTIONS .....                                | 5 |
| FIG. 2: TYPICAL PULSE WIDTH AND AMPLITUDE RESPONSE<br>CURVES .....  | 7 |
| FIG. 3: RELATIONSHIP BETWEEN TRIG, SYNC OUT AND MAIN<br>OUTPUT..... | 8 |
| PERFORMANCE CHECK SHEET .....                                       | 9 |

**FIG. 1: PULSE GENERATOR TEST ARRANGEMENT**

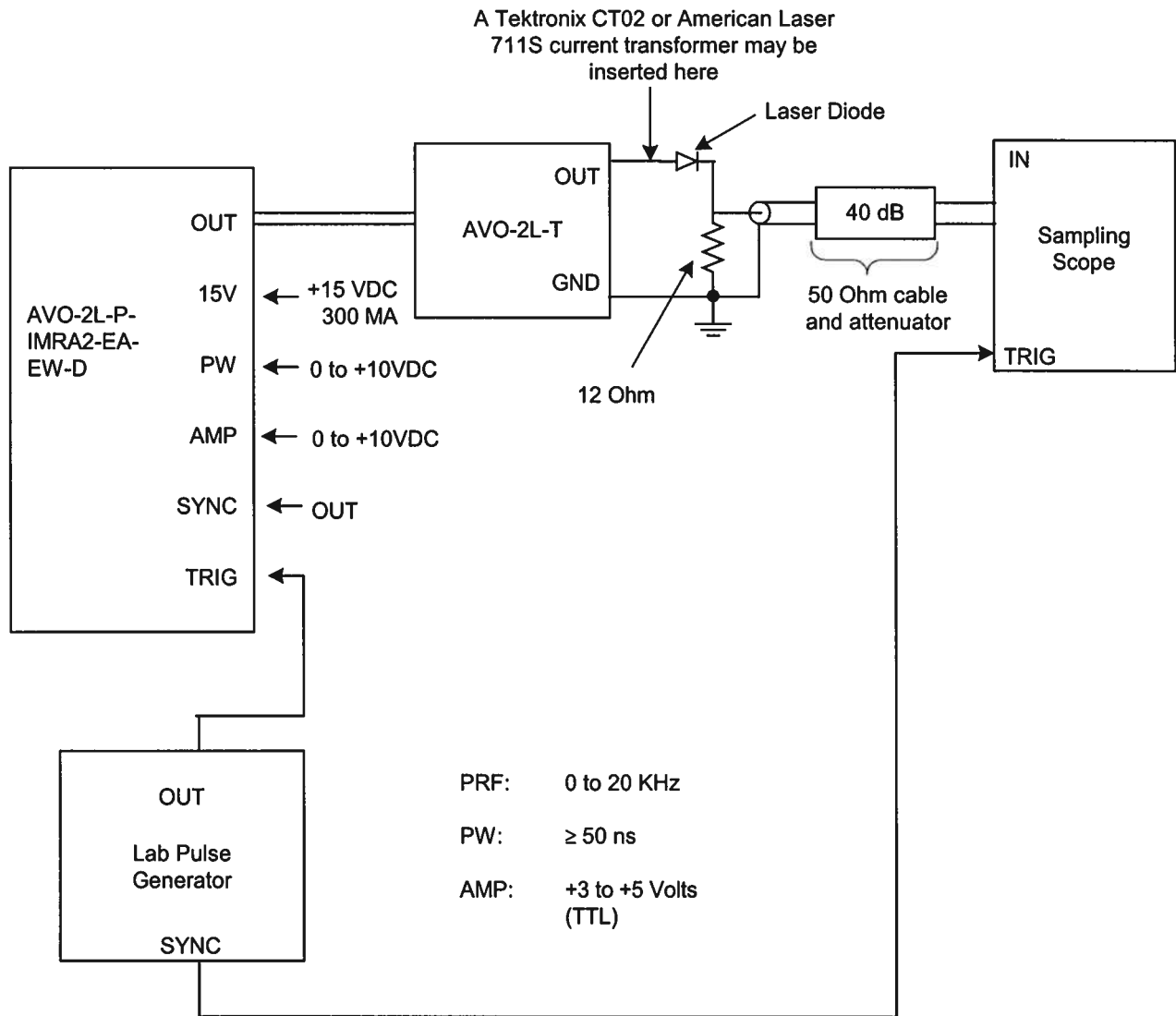

## GENERAL OPERATING INSTRUCTIONS

- 1) The bandwidth capability of components and instruments used to display the pulse generator output signal (attenuators, cables, connectors, etc.) should exceed two gigahertz.
- 2) The use of 40dB attenuator at the sampling scope vertical input channel will insure a peak input signal to the sampling scope of less than one Volt.
- 3) The AVO-2L-T module connects to the AVO mainframe via a 2-foot long miniature coaxial cable. The AVO-2-T module transforms the AVO mainframe output to 25 Volts to 12 Ohm. The laser diode is connected in series with a current limiting resistor ( $R_S = 12 \text{ Ohm}$ ) between the GND and OUT terminals on the AVO-2L-T.  $\frac{1}{4}$  Watt carbon film or carbon composition resistors may be used but all leads must be as short as possible ( $<0.1 \text{ inch}$ ). Solder leads directly to the GND and OUT terminals.  
**CAUTION:** Use moderate heat when soldering to the OUT terminal.

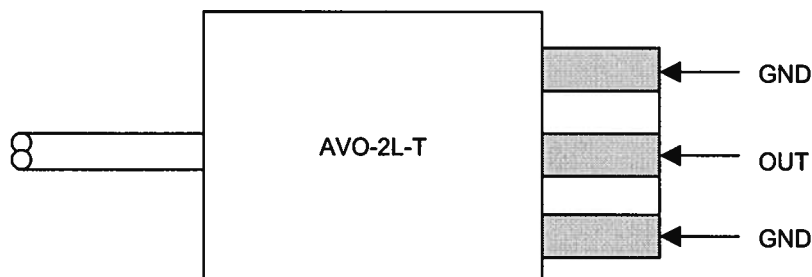

- 4) The output pulse width is controlled by the 0 to +10 VDC applied to the PW solder terminal ( $R_{IN} \geq 10K$ ). See Fig. 2 for the typical PW-Voltage relationship.
- 5) The output pulse amplitude is controlled by the 0 to +10VDC applied to the Amp solder terminal ( $R_{IN} \geq 10K$ ). See Fig. 2 for the typical PW-Voltage relationship. See Fig. 2 for the typical PW-Voltage relationship.
- 6) The diode current may be determined from the voltage measured across the 12 Ohm resistor in parallel with the 50 Ohm attenuator. Alternatively, a Tektronix CT- current probe or an American Laser 7115 current transformer may be used to measure the diode current directly.
- 7) The relationship between the input TRIG pulse, the SYNC OUT and the output current pulse are illustrated in Fig. 3. The delay of the output pulse relative to the SYNC pulse (or trigger in pulse) is controlled by the 10-turn "DELAY" trim pot on the top cover of the chassis.

- 8) Note that the unit may be damaged if triggered at a PRF exceeding 20 KHz.
- 9) For additional assistance:  
Tel: 613-226-5772  
Fax: 613-226-2802  
Email: [info@avtechpulse.com](mailto:info@avtechpulse.com)

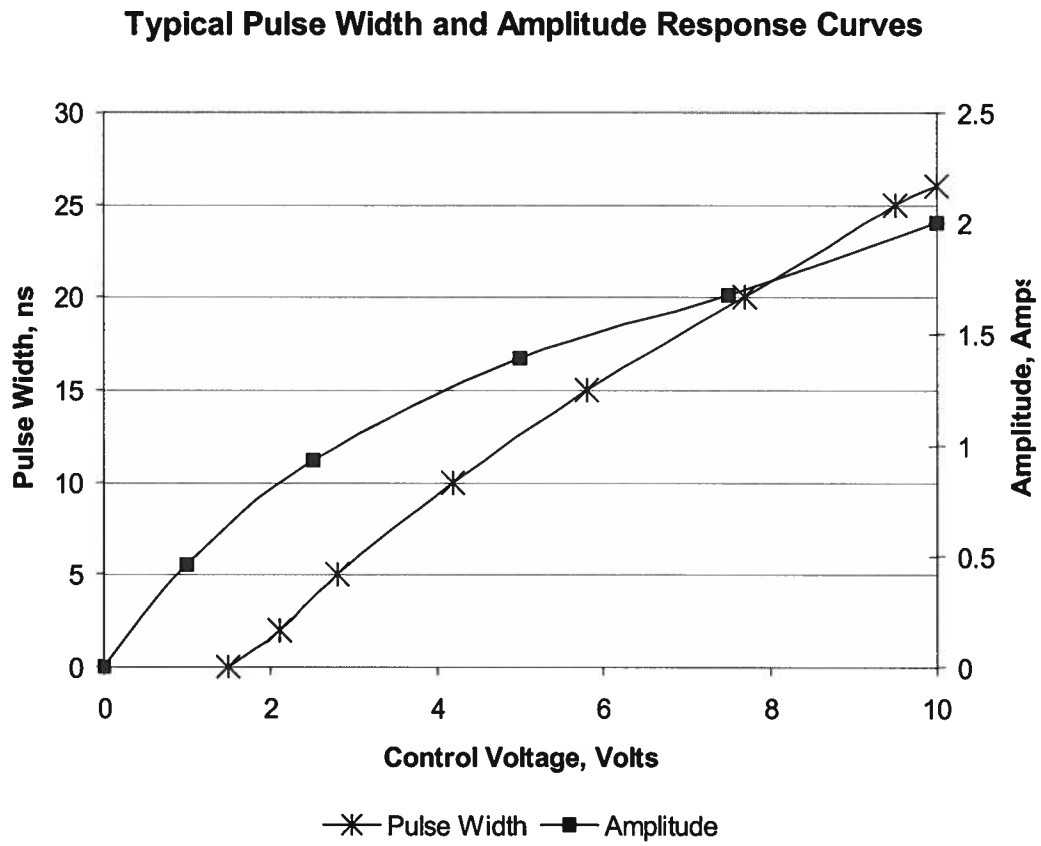
**FIG. 2: TYPICAL PULSE WIDTH AND AMPLITUDE RESPONSE CURVES**

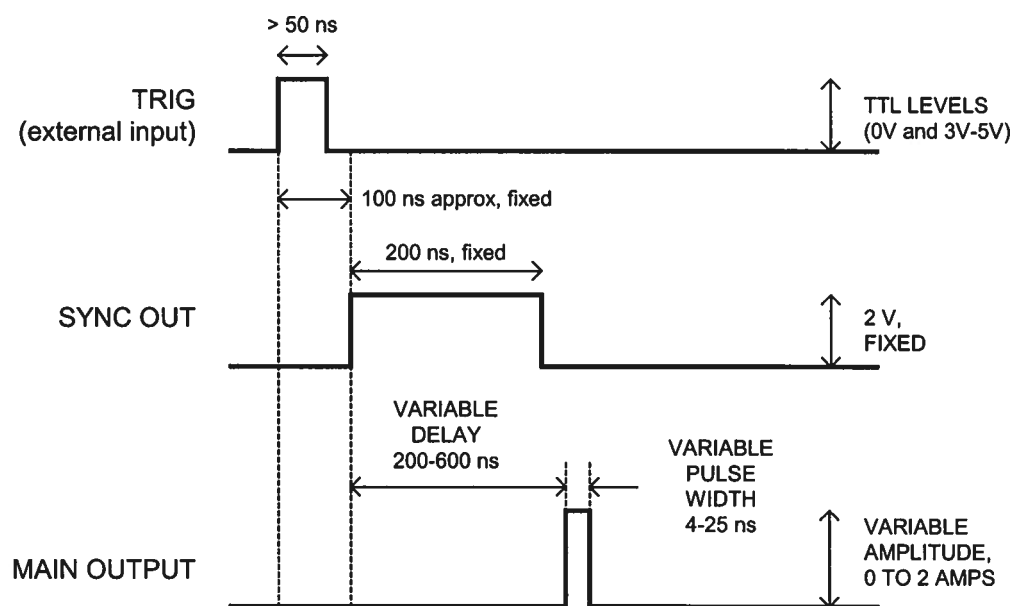
**FIG. 3: RELATIONSHIP BETWEEN TRIG, SYNC OUT AND MAIN OUTPUT**



nov 29/01  
(edition 1)