



AVTECH ELECTROSYSTEMS LTD.

NANOSECOND WAVEFORM ELECTRONICS
SINCE 1975

P. O. BOX 265
OGDENSBURG, NY
U.S.A. 13669-0265
TEL: (315) 472-5270
FAX: (613) 226-2802

TEL: 1-800-265-6681
FAX: 1-800-561-1970

e-mail: info@avtechpulse.com
<http://www.avtechpulse.com>

P.O. BOX 5120 STN. F
OTTAWA, ONTARIO
CANADA K2C 3H4
TEL: (613) 226-5772
FAX: (613) 226-2802

INSTRUCTIONS

MODEL AVO-6C-C PULSE GENERATOR

S.N.:

WARRANTY

Avtech Electrosystems Ltd. warrants products of its manufacture to be free from defects in material and workmanship under conditions of normal use. If, within one year after delivery to the original owner, and after prepaid return by the original owner, this Avtech product is found to be defective, Avtech shall at its option repair or replace said defective item. This warranty does not apply to units which have been disassembled, modified or subjected to conditions exceeding the applicable specifications or ratings. This warranty is the extent of the obligation assumed by Avtech with respect to this product and no other warranty or guarantee is either expressed or implied.

TECHNICAL SUPPORT

Phone: 613-226-5772 or 1-800-265-6681

Fax: 613-226-2802 or 1-800-561-1970

E-mail: info@avtechpulse.com

World Wide Web: <http://www.avtechpulse.com>

TABLE OF CONTENTS

WARRANTY	2
TABLE OF CONTENTS	3
FIG. 1: PULSE GENERATOR TEST ARRANGEMENT (AVO-6C-T OUTPUT MODULE REMOVED)	4
GENERAL OPERATING INSTRUCTIONS	5
FIG. 2: PULSE GENERATOR TEST ARRANGEMENT (AVO-6C-T OUTPUT MODULE CONNECTED).....	7
GENERAL INFORMATION	8
FIG. 3: AVO-6C-T	9
FIG. 4: FRONT PANEL CONTROLS	10
FRONT PANEL CONTROLS	11
FIG. 5: BACK PANEL CONTROLS.....	13
BACK PANEL CONTROLS.....	14
POWER SUPPLY AND FUSE REPLACEMENT	15
PERFORMANCE CHECK SHEET	17

**FIG. 1: PULSE GENERATOR TEST ARRANGEMENT
(AVO-6C-T OUTPUT MODULE REMOVED)**

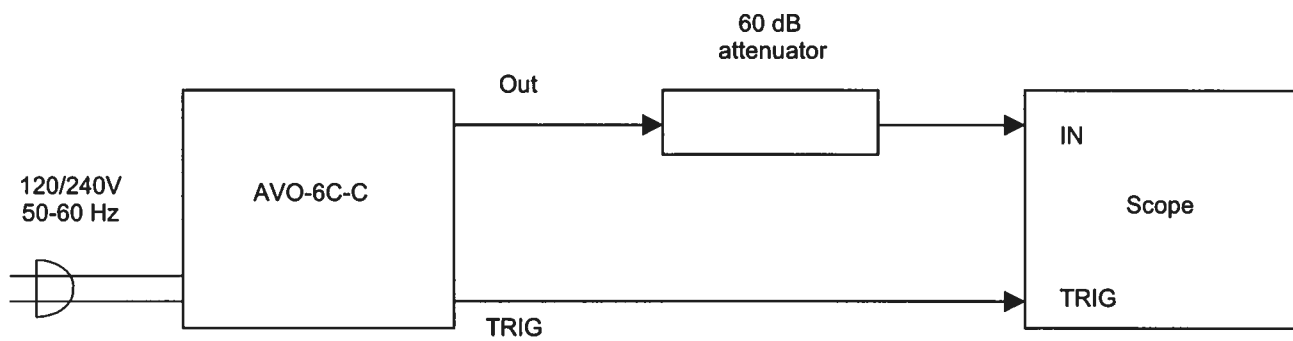

GENERAL OPERATING INSTRUCTIONS

- 1) The bandwidth capability of components and instruments used to display the pulse generator output signal (attenuators, cables, connectors, etc.) should exceed 100 MHz.
- 2) The use of a 60db attenuator at the scope vertical input channel will insure a peak input signal to the scope of less than one volt (necessary only if sampling scope used). If a high impedance real time scope is used, the pulse generator should be terminated using a shunt 50 Ohm resistor.
- 3) The TRIG output channel provides TTL level signals (+3V, 200 ns). The TRIG output precedes the main output when the front panel ADVANCE-DELAY switch is in the ADVANCE position. The TRIG output lags the main output when the switch is in the DELAY position.
- 4) To obtain a stable output display the PW and PRF controls on the front panel should be set mid range. The DELAY controls and the scope triggering controls are then adjusted to obtain a stable output. The scope may then be used to set the desired PRF by rotating the PRF controls.
- 5) The output pulse width is controlled by means of the front panel one turn PW control and the two-position range switch as follows:

50 – 500 ns
0.5 – 5.0 ns

- 6) The output pulse amplitude is controlled by means of the front panel one turn AMP control. To voltage control the output amplitude, set the rear panel switch in the EXT position and apply 0 to +10V to BNC connector A ($R_{IN} > 10K$). (EA option).
- 7) MONITOR Option. The rear panel M output port provides a coincident attenuated ($\times 10$) replica of the voltage pulse applied to the input of the AVO-6C-T module. The (Amps) are related as follows:

$$I_D = \frac{10 V_M - V_F}{50}$$

V_F = laser diode ON voltage, typically 2 Volts.

- 8) CAUTION: The output duty cycle must not exceed 1%. For example, for pulse width of less than 1 us, the PRF may be as high as 10 kHz. However, for pulse width of 5 us, the PRF must not exceed 2 kHz.

9) AVO-6C units with a serial number higher than 5600 are protected by an automatic overload protective circuit which controls the front panel overload light. If the unit is overloaded (by operating at an exceedingly high duty cycle or by operating into a short circuit), the protective circuit will turn the output of the instrument OFF and turn the indicator light ON. The light will stay ON (i.e. output OFF) for about 5 seconds after which the instrument will attempt to turn ON (i.e. light OFF) for about 1 second. If the overload condition persists, the instrument will turn OFF again (i.e. light ON) for another 5 seconds. If the overload condition has been removed, the instrument will turn on and resume normal operation. Overload conditions may be removed by:

- 1) Reducing PRF (i.e. switch to a lower range)
- 2) Reducing pulse width (i.e. switch to a lower range)
- 3) Removing output load short circuit (if any)

10) An external clock may be used to control the output PRF of the AVO unit by setting the front panel PRF range switch in the EXT position and applying a 50 ns (or wider) TTL level pulse to the TRIG BNC connector input. For operation in this mode, the scope time base must also be triggered by the external clock rather than from the TRIG output.

12) The unit can be converted from 120 to 240V 50-60 Hz operation by adjusting the voltage selector card in the rear panel fused voltage selector-cable connector assembly.

13) For additional assistance:

Tel: (613) 226-5772
Fax: (613) 226-2802
Email: info@avtechpulse.com

**FIG. 2: PULSE GENERATOR TEST ARRANGEMENT
(AVO-6C-T OUTPUT MODULE CONNECTED)**

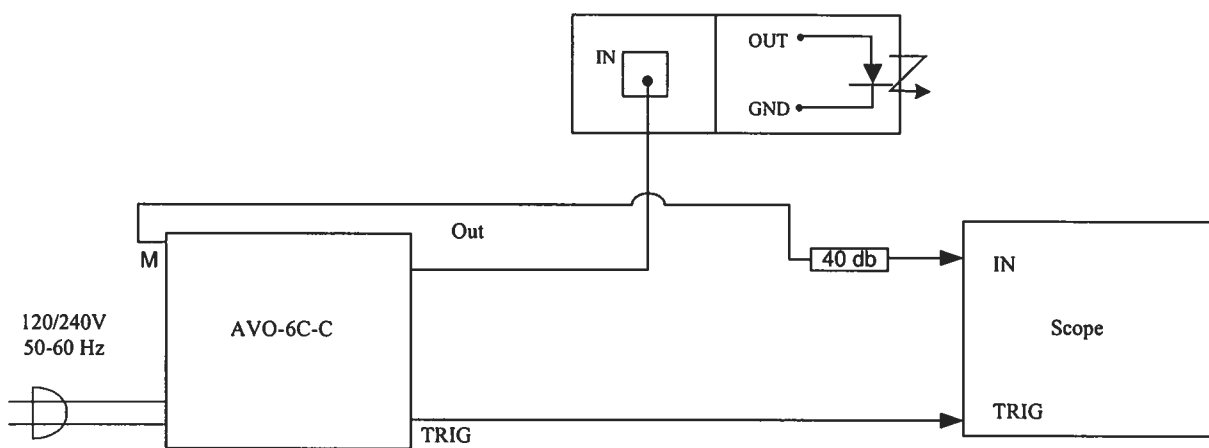

GENERAL INFORMATION

- 1) A general description of the AVO-6C-T module is given in fig. 3.
- 2) The AVO-6C-T module should be connected to the AVO-6C-C mainframe via the supplied 24" RG174 cable.
- 3) The laser diode is solder-connected between the OUT and GND terminals on the side of the AVO-6C-T module.
- 4) The mainframe provides a voltage pulse of up to 250 Volts to the 50 Ohms in series with the laser diode in the AVO-6C-T module (to provide a maximum current of 5 Amperes).
- 5) The M out port (on the mainframe) provides a voltage pulse (V_M) which is 0.1 of the amplitude of the voltage pulse applied to the input of the AVO-6C-T module. The voltage V_M (Volts) and diode current I_D (Amps) are related as follows:

$$I_D = \frac{10 V_M - V_F}{50}$$

V_F = laser diode ON voltage, typically 2 Volts.

- 6) The diode current may be monitored by means of a current probe (Tektronix CT2 or Pearson 2878).

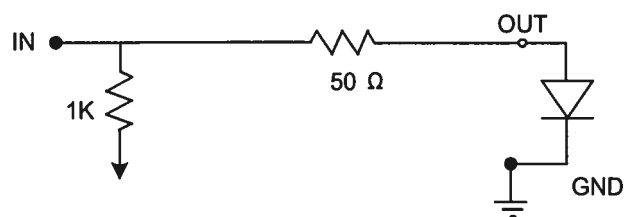
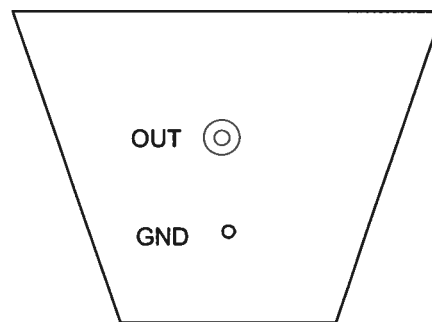
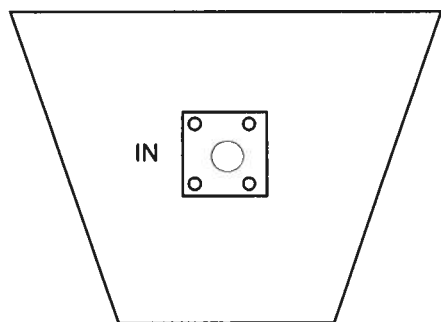
FIG. 3: AVO-6C-TFUNCTIONAL EQUIVALENT CIRCUIT

PACKAGE

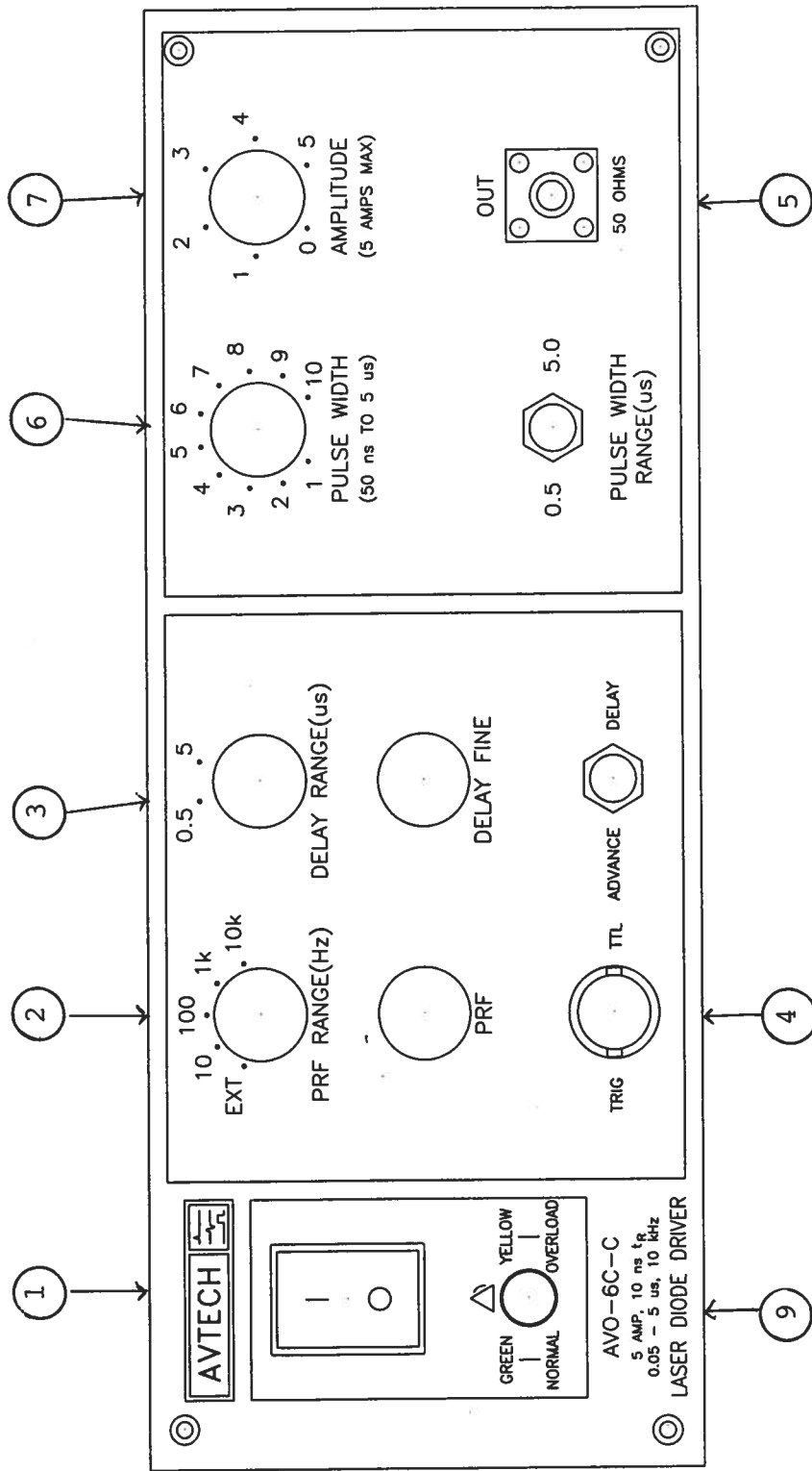

Fig. 4 FRONT PANEL CONTROLS

FRONT PANEL CONTROLS

- 1) ON-OFF Switch. Applies basic prime power to all stages.
- 2) PRF Control. With this range switch in the 10, 100, 1K, or 10K positions, the PRF of the unit is controlled via an internal clock which in turn is controlled by the PRF controls. With the range switch in the EXT position, the unit requires a 50 ns (or wider) TTL level pulse applied at the TRIG input in order to trigger the output stages.
- 3) DELAY Control. Controls the relative delay between the reference output pulse provided at the TRIG output (4) and the main output (5). This delay is variable over the range of 50 to about 500 ns (Range 1) or 0.5 to 5.0 us (Range 2). The TRIG output precedes the main output when the ADVANCE-DELAY switch is in the ADVANCE position and lags when the switch is in the DELAY position.
- 4) TRIG Output. When triggered internally, this output is used to trigger the scope time base. The output is a +3V 200 ns (approx) pulse capable of driving a fifty-Ohm load. Set scope to trigger on positive edge. The external trigger signal is applied at this point when the PRF INT toggle switch is in the EXT position.
- 5) OUT Connector. SMA connector provides output to AVO-6C-T module (250 Volts to 50 Ohms).
- 6) PW Control. A pot control and two-position range switch which vary the output pulse width from 50 to 0.5 us and 0.5 us to 5.0 us. **CAUTION:** The output duty cycle must not exceed 1%. For example, for pulse width of less than 1 us, the PRF may be as high as 10 kHz. However, for pulse width of 5 us, the PRF must not exceed 2 kHz.
- 7) AMP Control. A pot control which varies the output pulse amplitude from 0 to 250 V to a 50 Ohm load.
- 8) OVERLOAD Indicator. When the instrument is powered, this indicator is normally green, indicating normal operation. If this indicator is yellow, an internal automatic overload protection circuit has been tripped. If the unit is overloaded (by operating at an exceedingly high duty cycle or by operating into a very low impedance), the protective circuit will disable the output of the instrument and turn the indicator light yellow. The light will stay yellow (i.e. output disabled) for about 5 seconds after which the instrument will attempt to re-enable the output (i.e. light green) for about 1 second. If the overload condition persists, the output will be disabled again (i.e. light yellow) for another 5 seconds. If the overload condition has been removed, the instrument will resume normal operation.

This overload indicator may flash yellow briefly at start-up. This is not a cause for concern.

FIG. 5: BACK PANEL CONTROLS

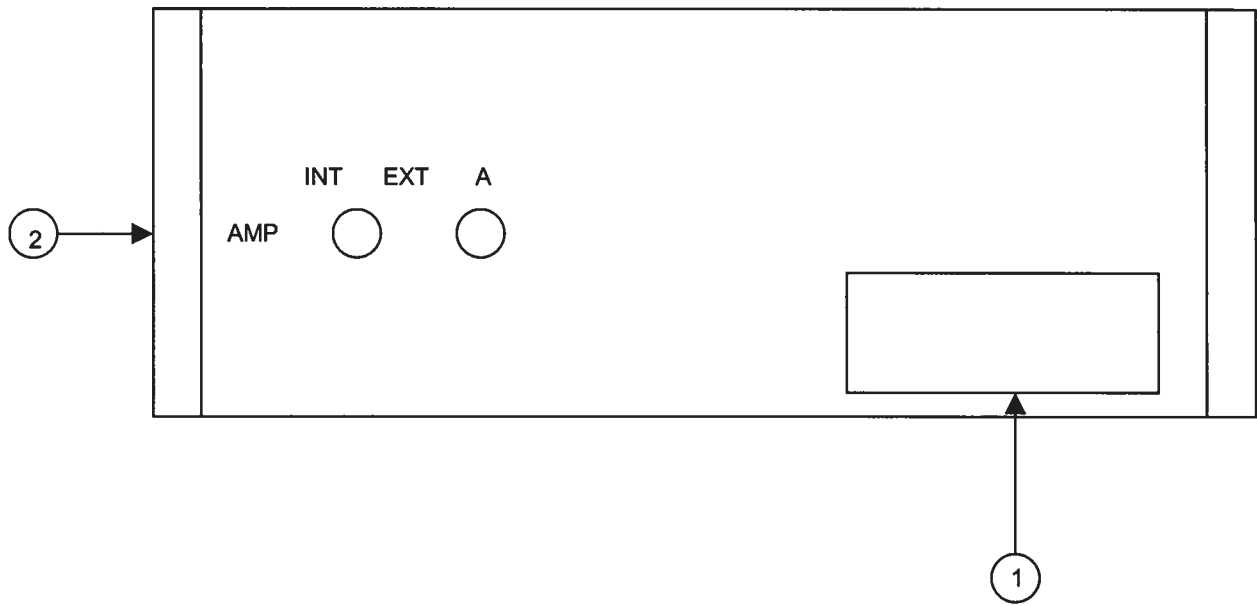

BACK PANEL CONTROLS

- 1) FUSED CONNECTOR, VOLTAGE SELECTOR. The detachable power cord is connected at this point. In addition, the removable cord is adjusted to select the desired input operating voltage. The unit also contains the main power fuse.

For AC line voltages of 110-120V, the power selector card should be installed so that the "120" marking is visible from the rear of the instrument.

For AC line voltages of 220-240V, the power selector card should be installed so that the "240" marking is visible from the rear of the instrument.

If it is not set for the proper voltage, remove the fuse and then grasp the card with a pair of pliers and remove it. Rotate horizontally through 180 degrees. Reinstall the card and the correct fuse.

In the 120V setting, a 0.5A slow blow fuse is required. In the 240V setting, a 0.25A slow blow fuse is required.

- 2) AMP. To voltage control the output amplitude, set the two-position switch in the EXT position and apply 0 to +10 V to BNC connector A ($R_{IN} \geq 10K$). (EA option).

POWER SUPPLY AND FUSE REPLACEMENT

This instrument has three main fuses, plus two spares. One, which protects the AC input, is located in the rear-panel power entry module, as described in the "Rear Panel Controls" section of this manual. If the power appears to have failed, check the AC fuse first.

The other two fuses (plus two spares) are located on the internal DC power supply, as shown below:

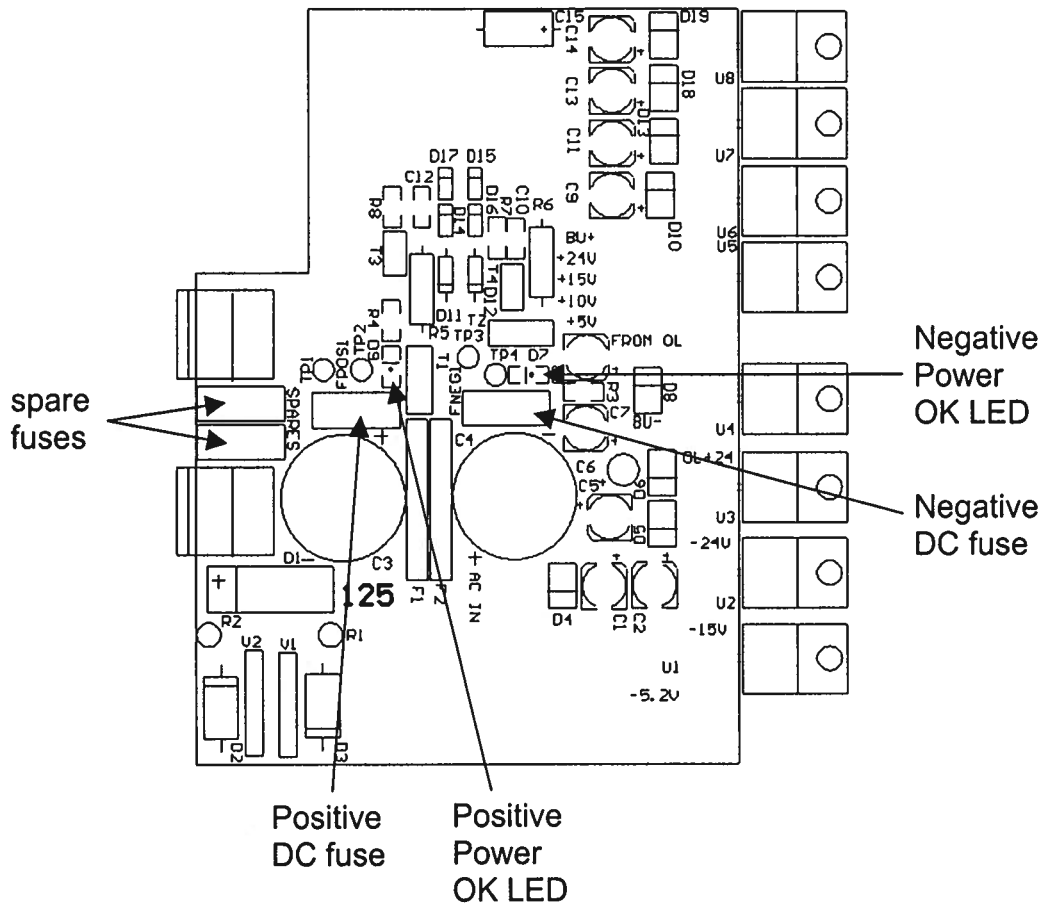

The positive fuse and one of the spare fuses on this circuit board are 1.5A slow-blow fuses, Littlefuse part number R45201.5. (This fuse can be ordered from Digikey, www.digikey.com. The Digikey part number is F1344CT-ND). The negative fuse and the second spare fuse are 0.5A slow-blow fuses (Littlefuse R452.500, Digikey part number F1341CT-ND).

If you suspect that the DC fuses are blown, follow this procedure:

1. Remove the top cover, by removing the four Phillips screws on the top cover and then sliding the cover back and off.
2. Locate the two "Power OK" LEDs on the power supply circuit board, as illustrated above.

3. Turn on the instrument.
4. Observe the "Power OK" LEDs. If the fuses are not blown, the two LEDs will be lit (bright red). If one of the LEDs is not lit, the fuse next to it has blown.
5. Turn off the instrument.
6. If a fuse is blown, use needle-nose pliers to remove the blown fuse from its surface-mount holder.
7. Replace the fuse. (Spare 1.5 Amp and 0.5 Amp fuses are provided on the circuit board. They may be transferred to the active fuse locations using needle-nose pliers.)

Aug 29, 2003 ed 2