



AVTECH ELECTROSYSTEMS LTD.

NANOSECOND WAVEFORM ELECTRONICS
SINCE 1975

□ P.O. BOX 265
OGDENSBURG, NY
U.S.A. 13669-0265
TEL: (315) 472-5270
FAX: (613) 226-2802

TEL: 1-800-265-6681
FAX: 1-800-561-1970

e-mail: info@avtechpulse.com
<http://www.avtechpulse.com>

□ P.O. BOX 5120 STN. F
OTTAWA, ONTARIO
CANADA K2C 3H4
TEL: (613) 226-5772
FAX: (613) 226-2802

INSTRUCTIONS

MODEL AVO-8C-PS-P PULSE GENERATOR

S.N.:

WARRANTY

Avtech Electrosystems Ltd. warrants products of its manufacture to be free from defects in material and workmanship under conditions of normal use. If, within one year after delivery to the original owner, and after prepaid return by the original owner, this Avtech product is found to be defective, Avtech shall at its option repair or replace said defective item. This warranty does not apply to units which have been disassembled, modified or subjected to conditions exceeding the applicable specifications or ratings. This warranty is the extent of the obligation assumed by Avtech with respect to this product and no other warranty or guarantee is either expressed or implied.

TECHNICAL SUPPORT

Phone: 613-226-5772 or 1-800-265-6681

Fax: 613-226-2802 or 1-800-561-1970

E-mail: info@avtechpulse.com

World Wide Web: <http://www.avtechpulse.com>

TABLE OF CONTENTS

WARRANTY	2
TABLE OF CONTENTS	3
FIG. 1: PULSE GENERATOR TEST ARRANGEMENT.....	4
GENERAL OPERATING INSTRUCTIONS.....	5
FIG. 2: FRONT PANEL CONTROLS	7
FRONT PANEL CONTROLS	8
FIG 3: BACK PANEL CONTROLS.....	9
BACK PANEL CONTROLS.....	10
START-UP CHECK LIST	11
PERFORMANCE CHECK.....	13

FIG. 1: PULSE GENERATOR TEST ARRANGEMENT

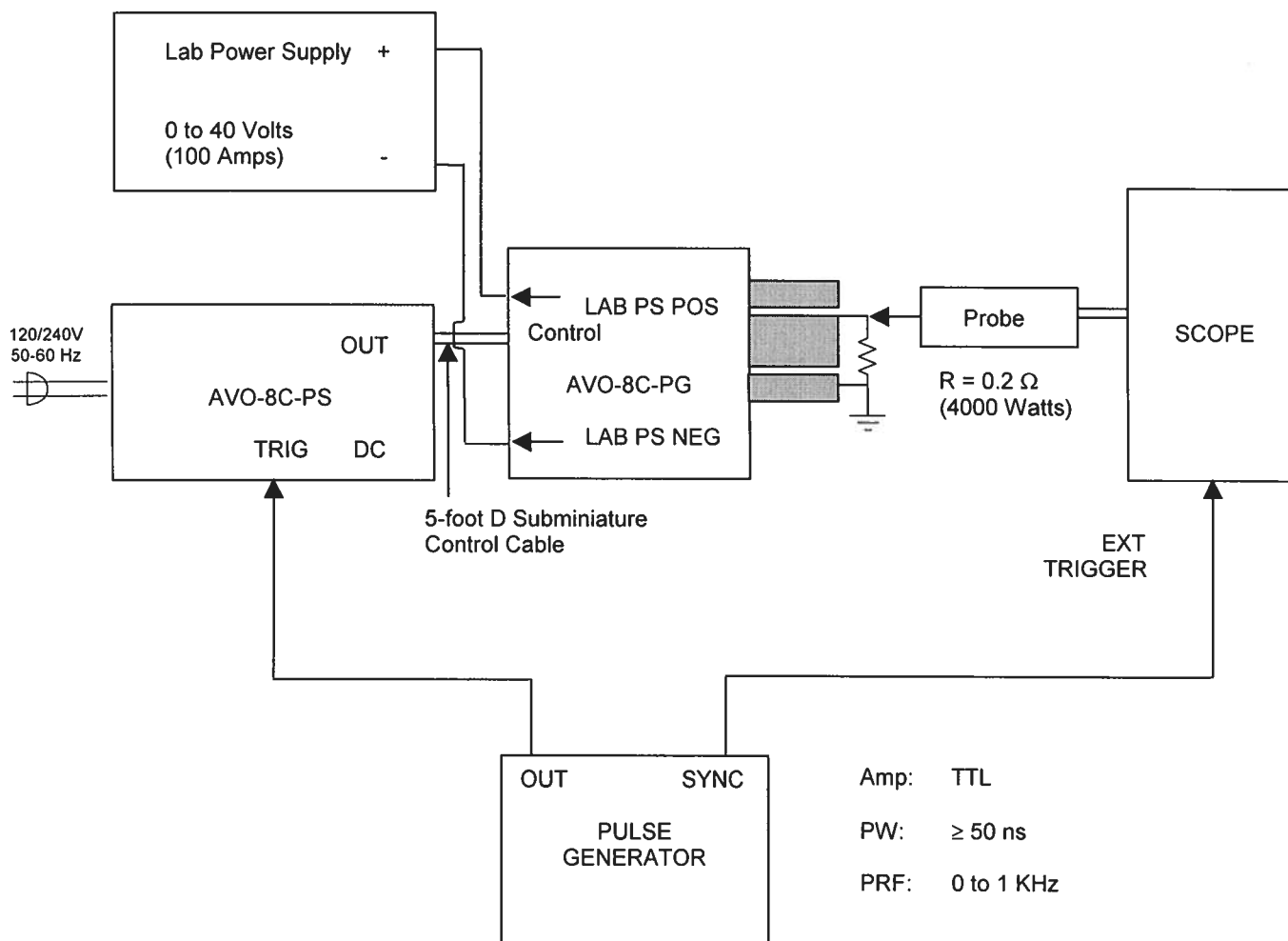

GENERAL OPERATING INSTRUCTIONS

- 1) The equipment should be connected in the general fashion shown above. Since the AVO unit provides an output pulse rise time as low as 0.1 μ s a fast oscilloscope (at least 50 MHz) should be used to display the waveform.
- 2) The user supplied lab power supply attaches to the -PG output module via the red and black SUPERCON connectors, which are supplied. The positive terminal of the power supply is to be connected to the RED SUPERCON connector on the -PG module. The negative terminal on the lab power supply is to be connected to the BLACK SUPERCON connector on the -PG module. For a -P unit, the negative terminal on the lab power supply must be grounded while for a -N unit the positive terminal must be grounded.
- 3) The 5-foot D subminiature cable must be connected between the "OUT" connector on the mainframe and the "CONTROL" connector on the output module.
- 4) The output terminals of the pulse generator module consists of a short length of microstrip transmission line protruding from the module chassis. The OUT terminal is the center conductor, which is bounded on both sides by the ground plane (see below). Note that the "OUT" red banana terminal is in parallel with the microstrip center conductor and so may also be used as the output terminal.

The load should be connected between the OUT and GND terminals using very short leads (≤ 2.0 cm).

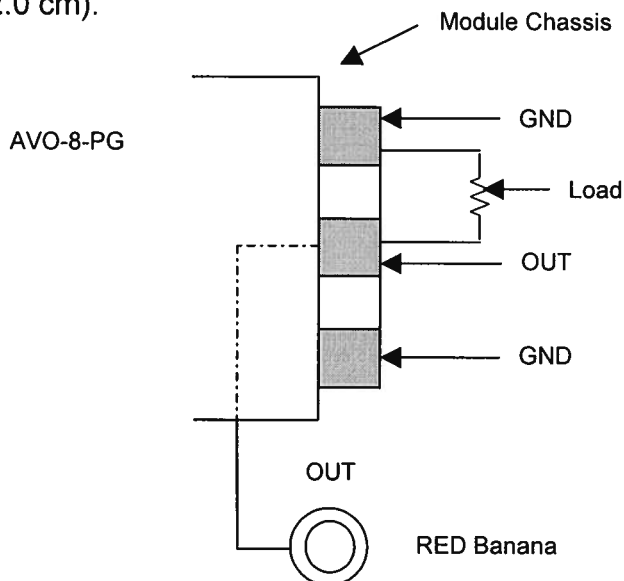

Take care to insure that during soldering, the OUT conductor is not shorted to the chassis. Also, use minimal heat when soldering.

- 5) When the PW MODE switch is in the A position, the output pulse width is controlled by the 4-position range switch and ten-turn fine control. The external clock may also be used to control the output pulse width by setting the PW mode switch in the B position (in this case, $PW_{OUT} = PW_{IN}$) and ground ($R_{IN} \geq 10K$). (option). (See (7) for PW control when the PW MODE switch is in the EXT position).
- 6) The output amplitude is controlled by the amplitude of the DC potential supplied to the SUPERCON connectors on the PG module.
- 7) The AVO-8C is designed to supply up to 200 amperes peak to a maximum load voltage of 40 volts. Factory tests are conducted with a 0.2 ohm load capable of dissipating at least 4000 watts. Higher load resistance values may be used but the input voltage must be limited to 40 volts or less. Note that the unit may fail if the average output current exceeds 100 Amp.
- 8) Model AVO-8C will operate with a duty cycle at least as high as 85% when the pulse width is controlled by the front panel Pulse Width and Pulse Width Range controls. A duty cycle of 100% is obtained by setting the pulse width mode switch in the B position. In this position the load voltage will be about 2.0 volts less than the applied DC voltage for a load current of 100 amperes. Note that the average output current must never exceed 100 Amp.
- 9) The unit can be converted from 120 to 240V 50-60 Hz operation by adjusting the voltage selector card in the rear panel fused voltage selector cable connector assembly.
- 10) The rear panel monitor output BNC (M) provides an output voltage (to 50 ohms or higher) which is proportional to the current flowing through the microstrip output terminals ($500 \text{ mV} \approx 200 \text{ Amps}$). Note that the monitor function is not connected to the banana output terminals (option).
- 11) Model AVO-8C-PS includes a high voltage protection circuit, which sounds a loud audible alarm if the applied DC voltage exceeds $\approx +45 \text{ VDC}$. The output stages of the unit will not trigger while the alarm is sounding. The unit also includes a temperature limit circuit, which sounds an audible alarm if the temperature of the output stage switching elements exceeds $+35^{\circ}\text{C}$ (this will occur if the average current exceeds 100 Amps).
- 12) If application assistance is required:

Tel: (613) 226-5772
Fax: (613) 226-2802
Email: info@avtechpulse.com

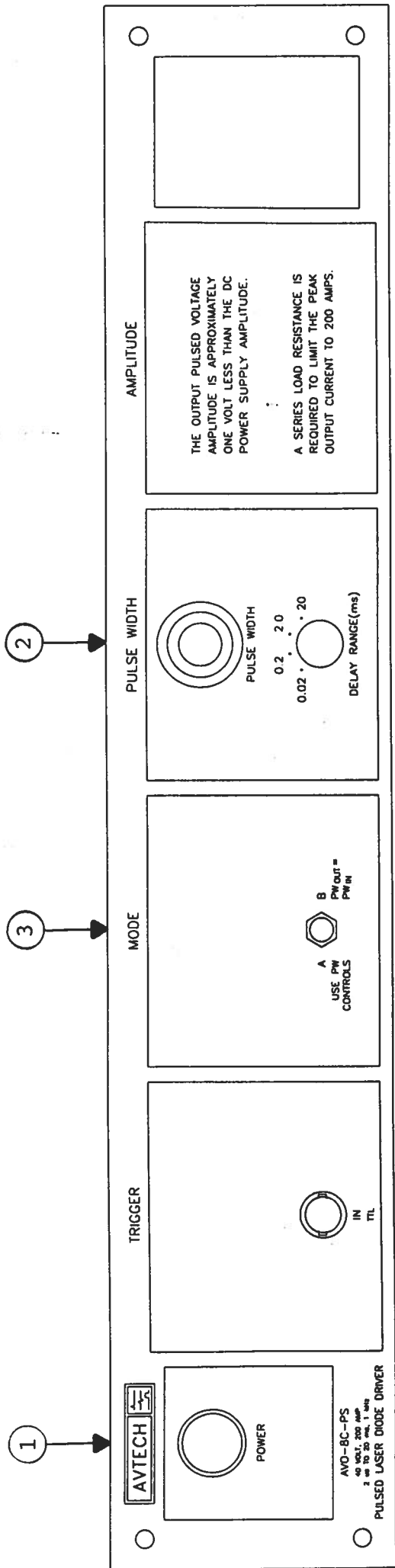

FIG. 2: FRONT PANEL CONTROLS

FRONT PANEL CONTROLS

- (1) ON-OFF Switch. Applies basic prime power to all stages.
- (2) PW Control. A one turn control and four position range switch which varies the output pulse width as follows (when the PW MODE switch is in the A mode):

Range 1	2.0 us to 20 us
Range 2	20 us to 200 us
Range 3	200 us to 2 ms
Range 4	2 ms to 20 ms
- (3) PW MODE. With the MODE switch in the A position the PW is controlled by the front panel controls. When the switch is in the B position, the PW is controlled by the TTL PW applied externally to the TRIG input. Model AVO-8C-PS will operate with a duty cycle at least as high as 85% when the PW MODE switch is in the A position and the pulse is controlled by the front panel Pulse Width and Pulse Width Range controls. A duty cycle of 100% is obtained by setting the MODE switch in the B position. In this position the PW controls are no longer active. In this position the load voltage will be about 2.0 volts less than the applied DC voltage for a load current of 100 amperes.
- (4) TRIG IN. A TTL trigger pulse (PW >50 ns) is applied to this BNC input connector.

FIG 3: BACK PANEL CONTROLS

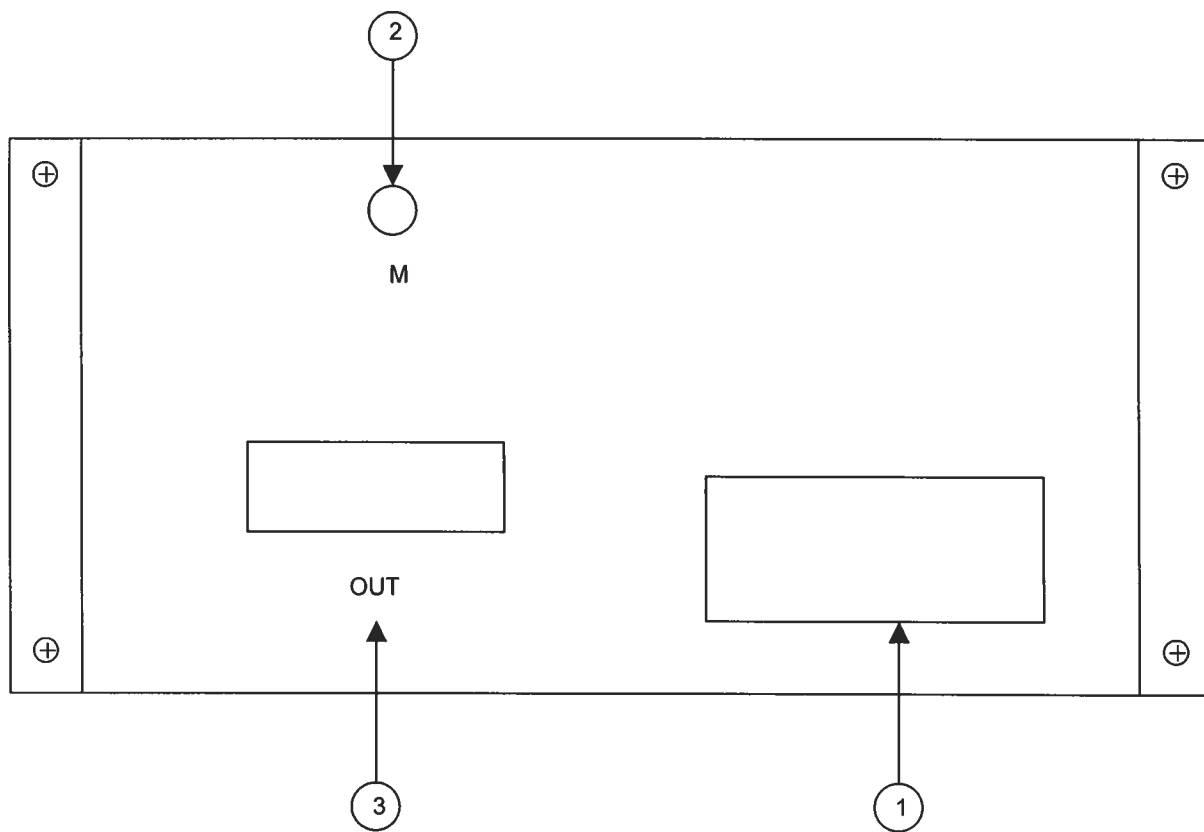

BACK PANEL CONTROLS

- (1) FUSED CONNECTOR, VOLTAGE SELECTOR. The detachable power cord is connected at this point. In addition, the removable cord is adjusted to select the desired input operating voltage. The unit also contains the main power fuse.

For AC line voltages of 110-120V, the power selector card should be installed so that the "120" marking is visible from the rear of the instrument.

For AC line voltages of 220-240V, the power selector card should be installed so that the "240" marking is visible from the rear of the instrument.

If it is not set for the proper voltage, remove the fuse and then grasp the card with a pair of pliers and remove it. Rotate horizontally through 180 degrees. Reinstall the card and the correct fuse.

In the 120V setting, a 0.5A slow blow fuse is required. In the 240V setting, a 0.25A slow blow fuse is required.

- (2) The monitor output BNC (M) provides an output voltage, which is proportional to the current flowing through the banana output terminals.

$$0.5V \approx 200 \text{ Amps}$$

- (3) OUT. The 5-foot D subminiature cable must be connected between this and the "CONTROL" connector on the output module.

START-UP CHECK LIST

- 1) The instruction manual has been studied thoroughly.
- 2) The -PG module is connected to the mainframe. The 5-foot D subminiature cable must be connected between the "OUT" connector on the mainframe and the "CONTROL" connector on the output module. (The output module should always be connected to the mainframe BEFORE power is applied).
- 3) The load is connected to the output module. If the load is a diode, the anode of the load is connected to the OUT terminal. Note that with a diode load, a current limiting high power resistor must be placed in series with the diode to help limit the peak current. For initial testing, it is recommended that a resistive load be used. Factory tests are conducted using a 0.2 Ohm 4000 Watt resistive load.
- 4) The user-supplied lab power supply is connected with the positive terminal connected to the red SUPERCON on the PG module and the negative terminal connected to the black SUPERCON. The negative terminal is grounded. The power supply potential is set to zero.
- 5) Set the mainframe pulse width controls at the approximate desired values and apply a TTL trigger pulse (>50 ns) to the BNC connector (while insuring that the duty cycle is less than 10%).
- 6) Set the MODE switch on the A position.
- 7) Connect the rear panel M output to the scope (1 VOLT/DIV) and connect the TRIG out to the scope time base. (option)
- 8) Turn on the prime power to the mainframe. The scope time base should be triggering.
- 9) Connect a scope probe across the resistive test load and apply prime power to the lab power supply (after first insuring that the output amplitude is set to zero).
- 10) Gradually increase the output amplitude on the lab power supply and observe the waveforms on the scope and the DC current level on the DC power supply. A rectangular pulse should appear on the scope (for both the load voltage and monitor channels) and the amplitude should increase as the amplitude control on the mainframe is rotated clockwise. At the same time, the average current supplied by the DC supply will increase. Observe the pulse width and pulse

period on the scope and confirm that the duty cycle does not exceed 10% and that the peak current does not exceed 200 Amps (i.e. 0.5 Volts out from the monitor output).

- 11) Observe the DC current supplied by the DC supply and insure that the average current does not exceed 100 Amperes.
- 12) Adjust pulse width, pulse period (i.e. PRF) and amplitude to obtain the desired settings.
- 13) If additional assistance is required:

Tel: (613) 226-5772
Fax: (613) 226-2802
Email: info@avtechpulse.com

Apr 24/2001