



□ P.O. BOX 265
OGDENSBURG, NY
U.S.A. 13669-0265
TEL: (315) 472-5270
FAX: (613) 226-2802

TEL: 1-800-265-6681
FAX: 1-800-561-1970
e-mail: info@avtechpulse.com
http://www.avtechpulse.com

□ P.O. BOX 5120 STN. F
OTTAWA, ONTARIO
CANADA K2C 3H4
TEL: (613) 226-5772
FAX: (613) 226-2802

INSTRUCTIONS

MODEL AVO-9C-C-N-QTKA

0 TO 100 mA, 300 ps RISE TIME

HIGH PERFORMANCE LASER DIODE DRIVER

WITH PLUG-IN SOCKET OUTPUT MODULE

SERIAL NUMBER: _____

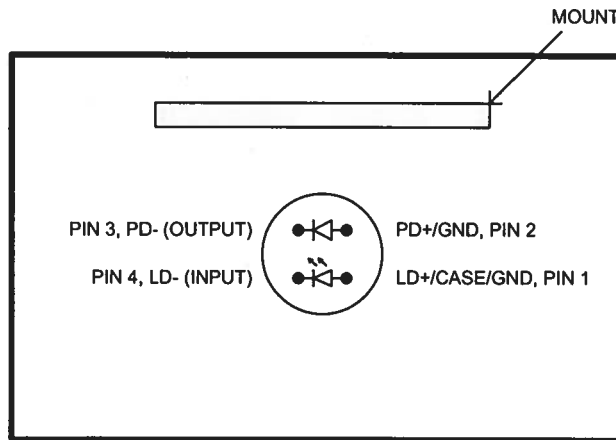

AVX-S1 OUTPUT MODULE, SOCKET VIEW

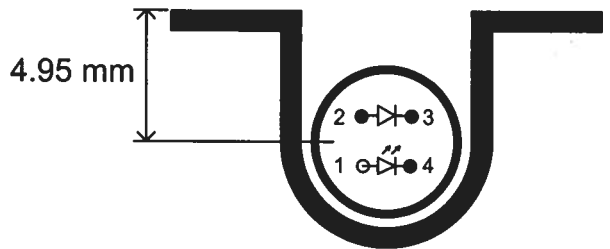

**MATCHING USER-SUPPLIED
DIODE PACKAGE
(BOTTOM VIEW)**

WARRANTY

Avtech Electrosystems Ltd. warrants products of its manufacture to be free from defects in material and workmanship under conditions of normal use. If, within one year after delivery to the original owner, and after prepaid return by the original owner, this Avtech product is found to be defective, Avtech shall at its option repair or replace said defective item. This warranty does not apply to units which have been disassembled, modified or subjected to conditions exceeding the applicable specifications or ratings. This warranty is the extent of the obligation assumed by Avtech with respect to this product and no other warranty or guarantee is either expressed or implied.

TECHNICAL SUPPORT

Phone: 613-226-5772 or 1-800-265-6681

Fax: 613-226-2802 or 1-800-561-1970

E-mail: info@avtechpulse.com

World Wide Web: <http://www.avtechpulse.com>

TABLE OF CONTENTS

<i>WARRANTY</i>	2
<i>TECHNICAL SUPPORT</i>	2
<i>TABLE OF CONTENTS</i>	3
<i>INTRODUCTION</i>	4
<i>SPECIFICATIONS</i>	5
<i>INSTALLATION</i>	6
VISUAL CHECK	6
PLUGGING IN THE INSTRUMENT	6
<i>FRONT PANEL CONTROLS</i>	8
<i>REAR PANEL CONTROLS</i>	10
<i>GENERAL INFORMATION</i>	11
MINIMAL TEST ARRANGEMENT - WITHOUT OUTPUT MODULE	11
NORMAL TEST ARRANGEMENT	12
INSTALLING THE DIODE	13
AMPLITUDE CONTROL	13
BASIC PULSE CONTROL	14
PULSE WIDTH / AMPLITUDE INTERACTION	14
TOP COVER REMOVAL	14
ELECTROMAGNETIC INTERFERENCE	15
RACK MOUNTING	15
<i>PROTECTING YOUR INSTRUMENT</i>	16
DO NOT EXCEED 25 MHz	16
USE A 50Ω LOAD	16
INSTALL THE DIODE CORRECTLY	16
<i>POWER SUPPLY AND FUSE REPLACEMENT</i>	17
<i>PERFORMANCE CHECKSHEET</i>	19

INTRODUCTION

The AVO-9C-C-N-QTKA is a high performance instrument capable of generating up to 100 mA of current into diode loads, at repetition rates up to 25 MHz.

The AVO-9C-C-N-QTKA consists of a mainframe unit and an AVX-S1 series output module, which provides a socket into which the user's laser diode may be inserted. The mainframe generates voltage pulses of between 0 and -7V. The output module connects to the instrument mainframe via a detachable 2 foot long coaxial cable. The output module contains the necessary elements to match the laser diode to the pulse generator mainframe. A DC bias current of 0 to ± 100 mA may be applied to the laser diode by applying the desired DC current to a solder terminal on the output module. The output modules include an SMA output connector that provides an attenuated coincident replica of the diode current.

The AVX-S1 output module supplied with the AVO-9C-C-N-QTKA is specifically designed to accommodate a Lasermate T15D-PFA2-B1 diode with the pinout illustrated below:

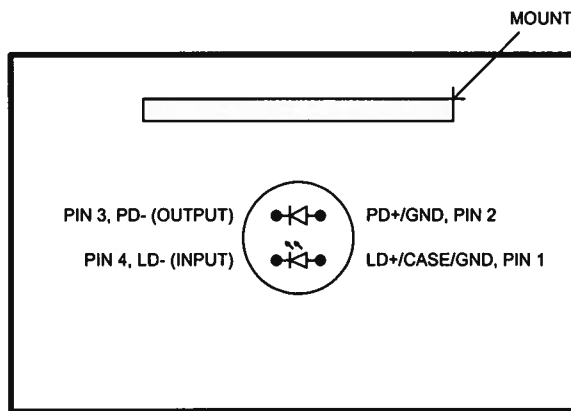

AVX-S1 OUTPUT MODULE, SOCKET VIEW

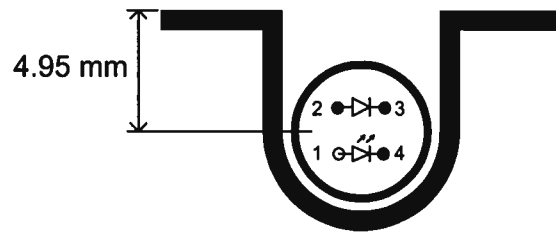

**MATCHING USER-SUPPLIED
DIODE PACKAGE
(BOTTOM VIEW)**

Note: the AVO-9C-C-N-QTKA generates a negative voltage at the mainframe output. The output module drives the cathode of the laser diode; the anode is grounded.

INSTALLATION

VISUAL CHECK

After unpacking the instrument, examine to ensure that it has not been damaged in shipment. Visually inspect all connectors, knobs, and handles. Confirm that a power cord, an output module, and a 2 foot coaxial cable are with the instrument. If the instrument has been damaged, file a claim immediately with the company that transported the instrument.

PLUGGING IN THE INSTRUMENT

Examine the rear of the instrument. There will be a male power receptacle, a fuse holder and the edge of the power selector card visible. Confirm that the power selector card is in the correct orientation.

For AC line voltages of 110-120V, the power selector card should be installed so that the "120" marking is visible from the rear of the instrument, as shown below:

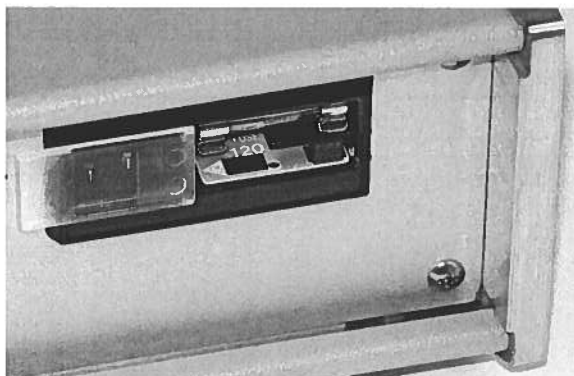

For AC line voltages of 220-240V, the power selector card should be installed so that the "240" marking is visible from the rear of the instrument, as shown below:

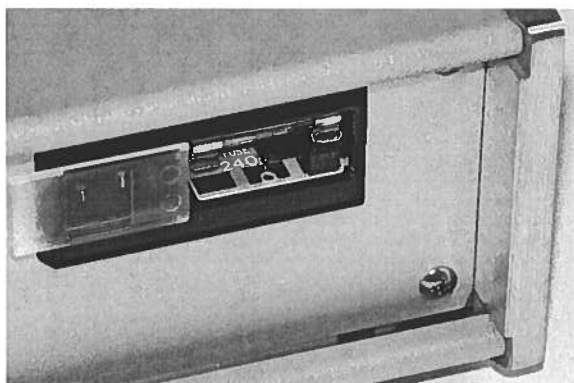

If it is not set for the proper voltage, remove the fuse and then grasp the card with a pair of pliers and remove it. Rotate horizontally through 180 degrees. Reinstall the card and the correct fuse.

In the 120V setting, a 0.5A slow blow fuse is required. In the 240V setting, a 0.25A slow blow fuse is required.

FRONT PANEL CONTROLS

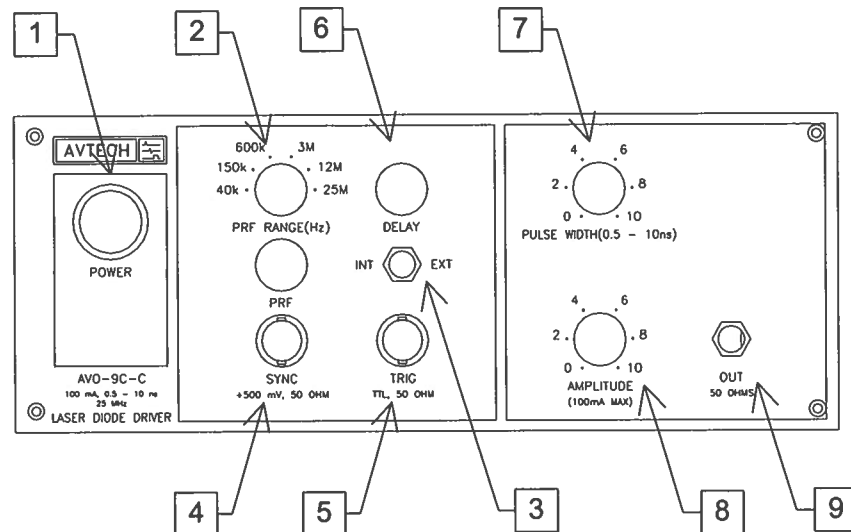

1. **POWER Switch.** The POWER push button switch applies AC prime power to the primaries of the transformer, turning the instrument on. The push button lamp is connected to the internal +15V DC supply.
2. **PRF Range Switch.** This switch sets the pulse repetition frequency (PRF) range of the internal oscillator. The internal oscillator triggers the instrument when the INT/EXT switch is in the "INT" position. The marked value of each position is the upper limit range, approximately. The vernier dial directly below the switch varies the PRF within the set range.
3. **INT/EXT Switch.** When this switch is in the "INT" position, the instrument is triggered by the internal oscillator, whose frequency is set by the PRF controls (item 2). When this switch is set to "EXT", the instrument is triggered by a TTL pulse applied to the TRIG connector (item 5).
4. **SYNC Connector.** When the INT/EXT switch is in the "INT" position, this output connector supplies a 0.5V, 20 ns wide pulse for each trigger event. This output may be used to trigger oscilloscopes or other equipment.
5. **TRIG Connector.** When the INT/EXT switch is set to "EXT", the instrument is triggered by a TTL pulse applied to this connector. The pulse must be at least 10 ns wide.
6. **Delay Controls.** When the INT/EXT switch is in the "INT" position, the main output is delayed relative to the SYNC output pulse (item 4). The delay is variable up to 200

ns, approximately, using the DELAY control.

7. Pulse Width Control. This dial controls the pulse width.
8. Amplitude Control. This dial controls the pulse amplitude.
9. OUT Connector. This SMA connector is connected to the output module, when the output module is used to drive a diode load. If the output module is not used, this output will generate up to -7V into a load impedances of 50Ω . (NOTE: when the output module is not used, this output *requires* a 50Ω load to function properly).

REAR PANEL CONTROLS

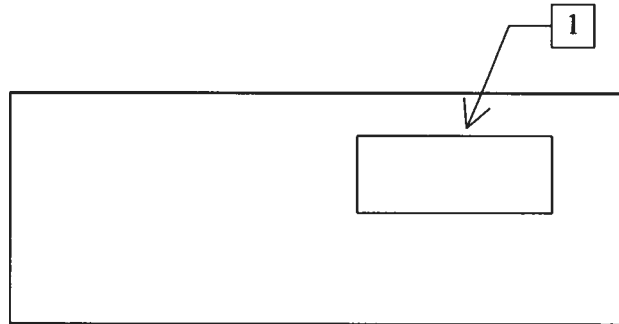

1. **AC POWER INPUT.** A three-pronged recessed male connector is provided on the back panel for AC power connection to the instrument. Also contained in this assembly is a slow-blow fuse and a removable card that can be removed and repositioned to switch between 120V AC in and 240V AC in.

For AC line voltages of 110-120V, the power selector card should be installed so that the "120" marking is visible from the rear of the instrument.

For AC line voltages of 220-240V, the power selector card should be installed so that the "240" marking is visible from the rear of the instrument.

If it is not set for the proper voltage, remove the fuse and then grasp the card with a pair of pliers and remove it. Rotate horizontally through 180 degrees. Reinstall the card and the correct fuse.

In the 120V setting, a 0.5A slow blow fuse is required. In the 240V setting, a 0.25A slow blow fuse is required. See the "Installation" section for more details.

GENERAL INFORMATION

MINIMAL TEST ARRANGEMENT - WITHOUT OUTPUT MODULE

The AVO-9C-C-N-QTKA can be tested initially without the supplied output module. If the output module is not used, the mainframe output generates 0 to -7V into a 50 Ohm load, as illustrated below:

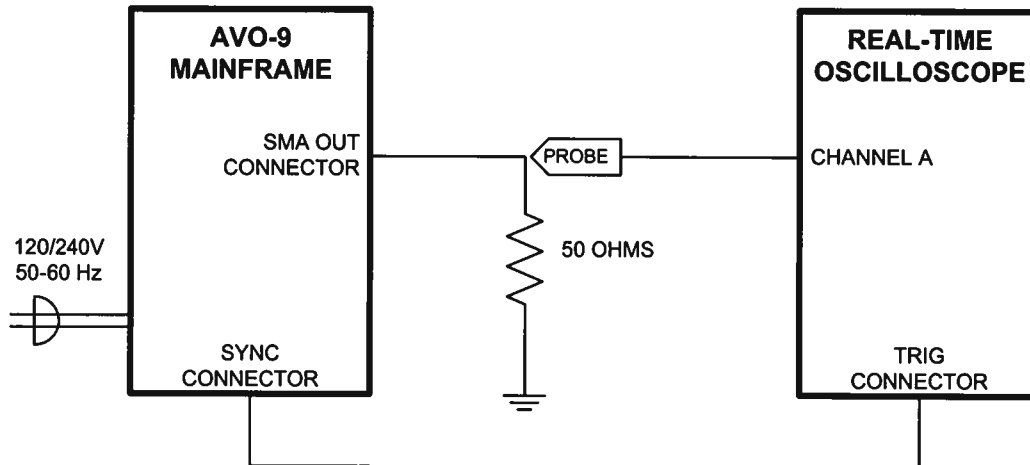

Since the AVO-9C-C-N-QTKA can generate pulses with rise times as low as 300 ps, it may be necessary to use a sampling oscilloscope, rather than a real-time oscilloscope. In this case, the test arrangement should be altered as shown below:

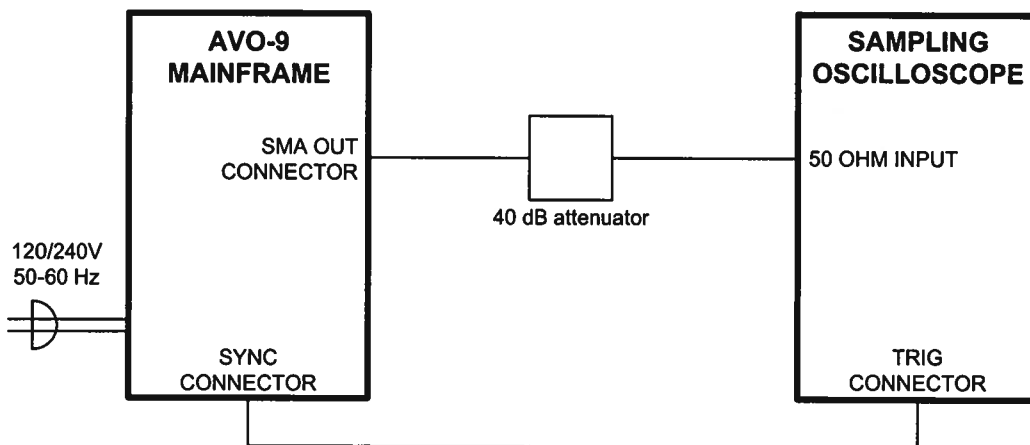

Since most sampling oscilloscopes have limited input amplitude ranges, an attenuator on the AVO-9 output is normally required.

When the output module is not used, a 50 Ohm load impedance is *required* for proper test operation.

NORMAL TEST ARRANGEMENT

To fully test the instrument, and for normal operation, the output module must be connected as shown below:

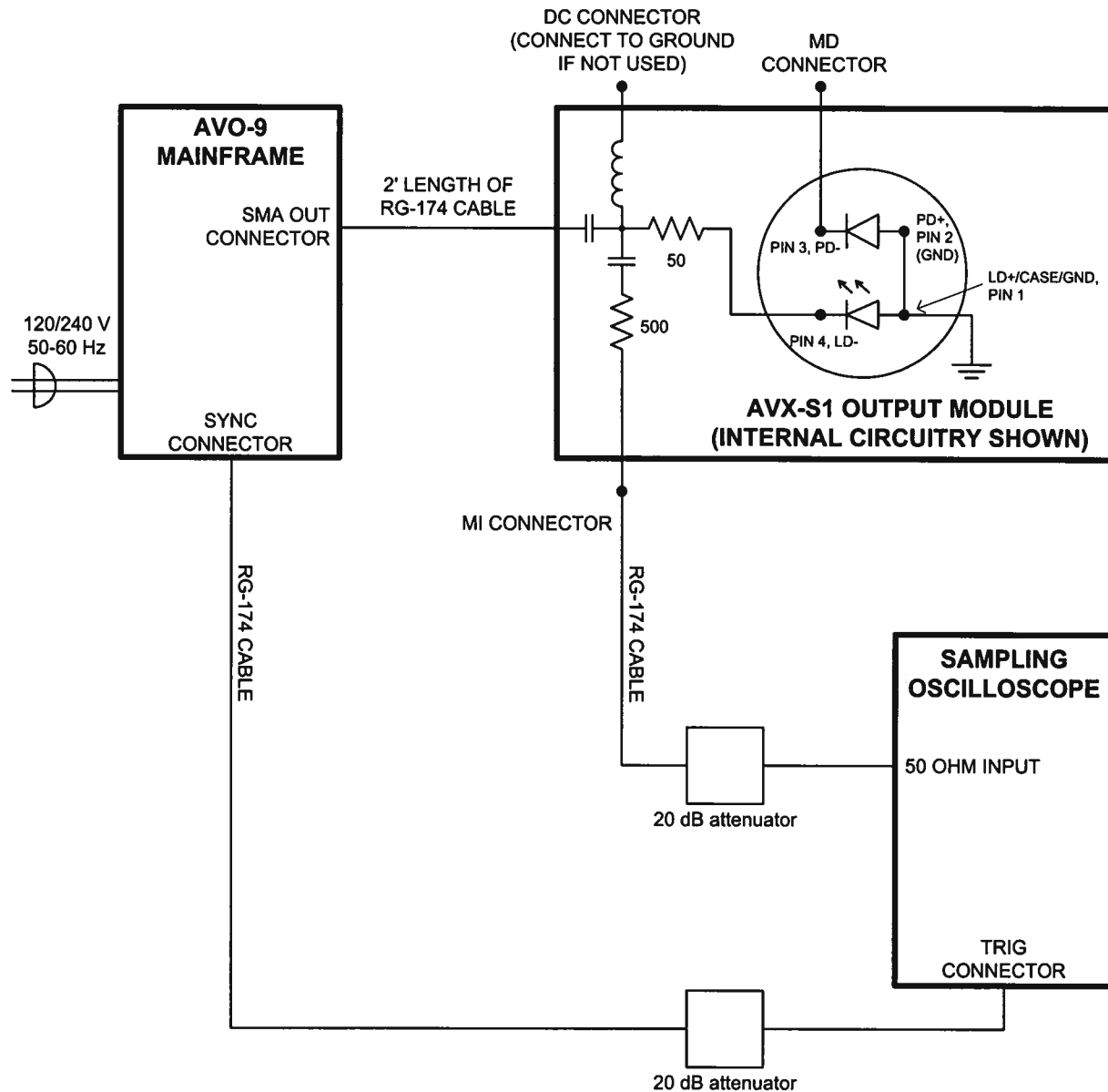

The diode load is inserted into the socket on the output module, as shown above.

An oscilloscope may be used to monitor the MI and MD outputs, the locations of which are shown in the figure above. A forward DC bias may be applied to the laser diode by connecting a DC potential of 0 to -5 Volts to the DC solder terminal. The application of a small forward bias often yields a more ideal diode current waveform (as observed on the MI port). The DC port must be shorted to ground if a bias is not applied.

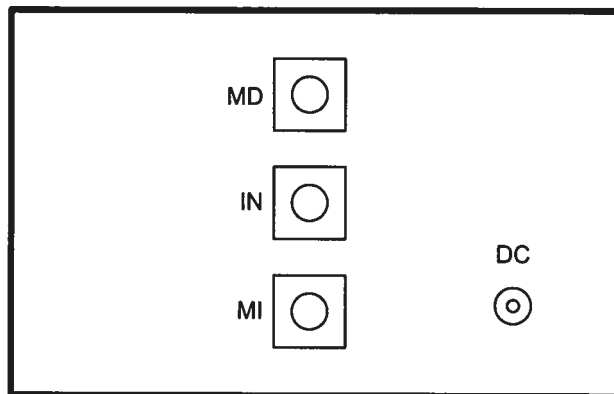

AVX-S1 OUTPUT MODULE, CONNECTOR VIEW

INSTALLING THE DIODE

To install the diode in the output module socket, align the diode so that the pins of the diode are aligned with the matching pin sockets on the output module, as shown below. Gently and slowly insert the diode into the socket. Insert it far enough that the mounting holes on the diode align with the mounting holes on the support bracket. Secure the diode to the support bracket using two screws.

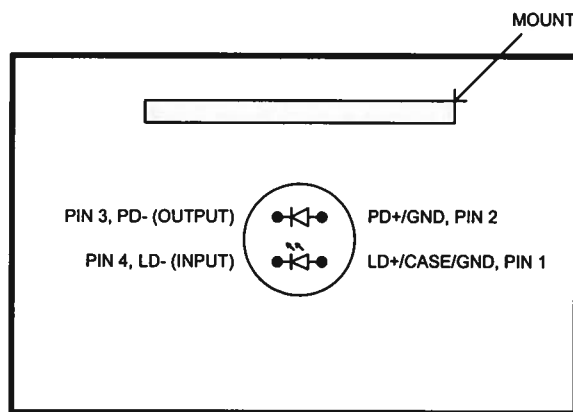

AVX-S1 OUTPUT MODULE, SOCKET VIEW

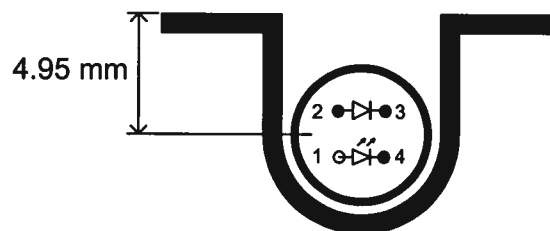

**MATCHING USER-SUPPLIED
DIODE PACKAGE
(BOTTOM VIEW)**

AMPLITUDE CONTROL

When using the output module, the pulse current through the diode load is given by:

$$I_{DIODE} = \frac{V_{SET} - V_{DIODE}}{50\Omega}$$

where V_{SET} is the amplitude setting on the mainframe (between 0 and 7V), and V_{DIODE} is the forward voltage drop across the diode (typically 2 or 3V).

BASIC PULSE CONTROL

This instrument can be triggered by its own internal clock or by an external TTL trigger signal. When triggered internally, two mainframe output channels respond to the trigger: OUT and SYNC.

- OUT. This is the main output. The maximum output voltage is -7V.
- TRIG. The TRIG pulse is a fixed-width TTL-level reference pulse used to trigger oscilloscopes or other measurement systems.

These pulses are illustrated below:

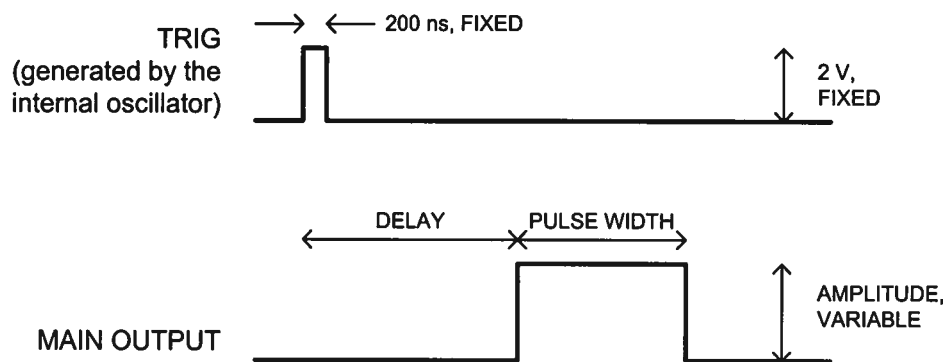

Figure A

When triggered externally, the TRIG connector acts as an input. The delay controls do not function in this mode.

PULSE WIDTH / AMPLITUDE INTERACTION

The pulse width and delay of the output pulse may vary slightly with the amplitude setting, particularly at lower amplitudes. For some demanding applications, it may be desirable to use external attenuators in conjunction with the AVO-9C-C-N-QTKA, instead of generating a low-amplitude pulse directly.

TOP COVER REMOVAL

The interior of the instrument may be accessed by removing the four Phillips screws on the top panel. With the four screws removed, the top cover may be slid back (and off).

ELECTROMAGNETIC INTERFERENCE

To prevent electromagnetic interference with other equipment, all used outputs should be connected to shielded 50Ω loads using shielded 50Ω coaxial cables. Unused outputs should be terminated with shielded 50Ω BNC terminators or with shielded BNC dust caps, to prevent unintentional electromagnetic radiation. All cords and cables should be less than 3m in length.

RACK MOUNTING

A rack mounting kit is available. The -R5 rack mount kit may be installed after first removing the one Phillips screw on the side panel adjacent to the front handle.

PROTECTING YOUR INSTRUMENT

DO NOT EXCEED 25 MHz

The output stage may be damaged if triggered by an external signal at a pulse repetition frequency greater than 25 MHz.

USE A 50Ω LOAD

The mainframe output stage may be damaged if the output is not terminated into the output module or a 50Ω dummy load.

INSTALL THE DIODE CORRECTLY

NOTE: Please note that care must be taken to insert the diode in the correct orientation. It is possible to insert it incorrectly, which may cause damage to the diode and the output module.

POWER SUPPLY AND FUSE REPLACEMENT

This instrument has three main fuses, plus two spares. One, which protects the AC input, is located in the rear-panel power entry module, as described in the “Rear Panel Controls” section of this manual. If the power appears to have failed, check the AC fuse first.

The other two fuses (plus two spares) are located on the internal DC power supply, as shown below:

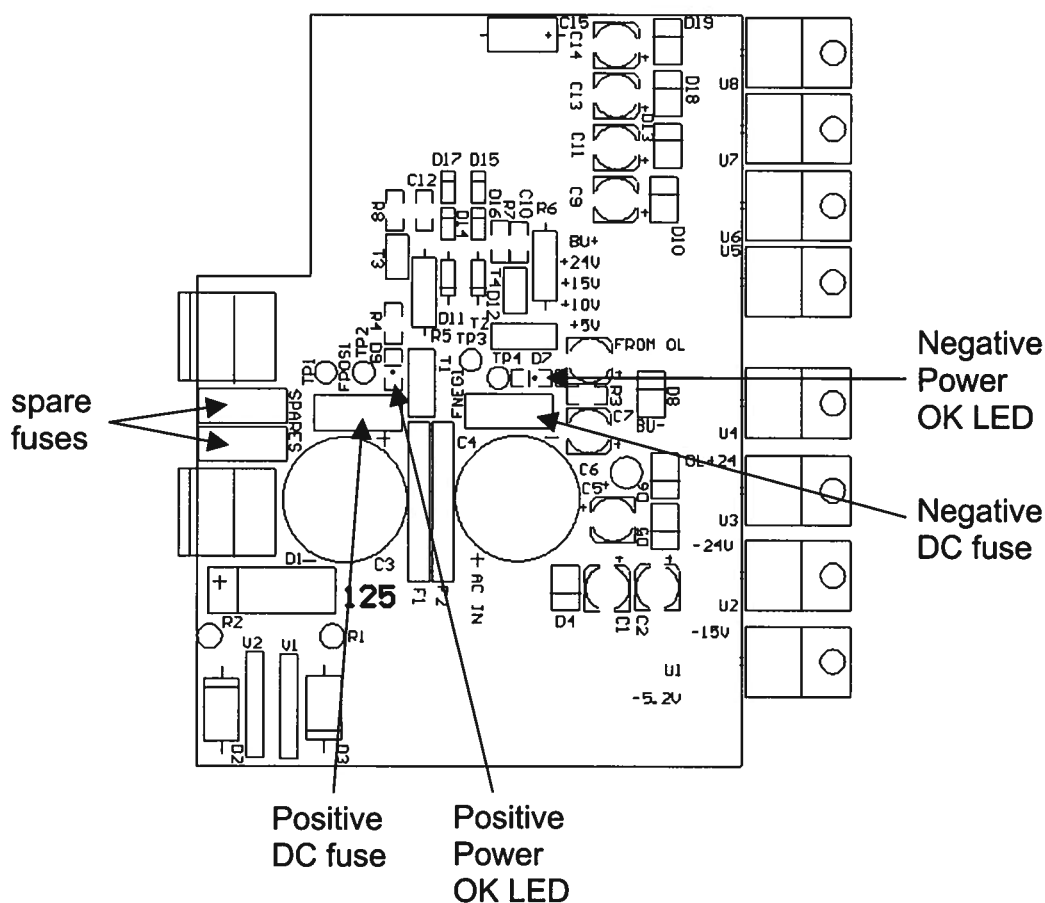

The positive fuse and one of the spare fuses on this circuit board are 1A slow-blow fuses, Littlefuse part number R452001. (This fuse can be ordered from Digikey, www.digikey.com. The Digikey part number is F1343CT-ND). The negative fuse and the second spare fuse are 0.5A slow-blow fuses (Littlefuse R452.500, Digikey part number F1341CT-ND).

If you suspect that the DC fuses are blown, follow this procedure:

1. Remove the top cover, by removing the four Phillips screws on the top cover and then sliding the cover back and off.

2. Locate the two "Power OK" LEDs on the power supply circuit board, as illustrated above.
3. Turn on the instrument.
4. Observe the "Power OK" LEDs. If the fuses are not blown, the two LEDs will be lit (bright red). If one of the LEDs is not lit, the fuse next to it has blown.
5. Turn off the instrument.
6. If a fuse is blown, use needle-nose pliers to remove the blown fuse from its surface-mount holder.
7. Replace the fuse. (Spare 1 Amp and 0.5 Amp fuses are provided on the circuit board. They may be transferred to the active fuse locations using needle-nose pliers.)

July 8/02

